

Quality Changes the World



Single Drum Roller

SSR130C-10H



Original Instructions Manual

Operation and Maintenance Manual



SSR Series Single Drum Roller

Operation & Maintenance Manual

 **WARNING**

Read and follow the safety precautions and instructions in this manual and on the machine decals. Failure to do so can cause serious injury, death or property damage. Keep this manual with the machine for reading and future reference.

SANY Europe GmbH

Sany Allee 1
50181 Bedburg
Germany

www.sanyeurope.com
info@sanyeurope.com

Tel.: +49 2272 90531 100

©2023 by Sany Group. All rights reserved. No part of this publication may be reproduced, used, distributed or disclosed except for normal operation of the machine as described herein. All information included within this publication was accurate at the time of publication. Product improvements, revisions, etc., may result in differences between your machine and what is presented here. Sany Group assumes no liability. For more information, contact Sany Group.

RESPONSIBILITY

SPECIFIC DECLARATION

The single drum roller is designed for compacting operation. Any other use or any operation beyond the specified working range is not authorized use. Sany expressly bears no liability for any consequence due to any unauthorized use.

Information on this manual is used to guide qualified operators to operate and maintain rollers correctly. SANY expressly bears no liability for any consequence due to any user not observing the information on this manual.

It is forbidden to convert the roller without authorization. SANY expressly bears no liability for any consequence. When crack or electrical malfunction on the roller occurs, please contact the supplier, and don't conduct welding or make changes without permission, or else, for any consequence due to such contravention, SANY shall not bear any liability.

Use genuine spare parts from SANY. SANY expressly bears no liability for any machine damage or accident due to the use of untested or unauthorized spare parts or tools.

Operational and maintenance parts (such as engine, a/c) on the roller should follow related regulations on Users' guide supplied from their manufacturer.

SANY expressly bears no liability for any machine failure or damage due to force majeure of natural disasters (earthquake, typhoon) and wars.

SANY cannot predict every circumstance that might involve a potential hazard in operation or maintenance. Operators and owners should highly attach importance to safety. Local specific safety rules of the countries may be stricter. If they differ from the regulations on this manual, observe the stricter one.

Duty of SANY

- Be responsible for providing qualified products and correct documents.
- Fulfill their promises on after-sales service, and document all maintenance and repair working done by after-sales service personnel.
- Train the operation and maintenance personnel based on their needs.

Duty of owners or other authorized personnel

- Only after each person involved in the product's operation, maintenance and repair is trained adequately and fully understands the Parts Book and Operation and Maintenance Manual, they can operate and maintain the roller.
- Ensure the operation and maintenance personnel are qualified and know their related responsibilities
- Periodically check related personnel's safety consciousness during working.

- If any fault threatening safety occurs, stop the roller immediately.
- If necessary SANY service personnel have the right to check the roller for safety.
- Besides recommended inspection items regulated by SANY, observe local laws and regulations to inspect the roller.
- Ensure timely maintenance and repair on the roller.
- Carefully plan the use of the roller.

Duty of all working personnel

- If there is any abnormal symptom which may cause abnormal working of the roller or potential hazard, report to your leader. If possible, correct fault in time.
- All personnel working around the roller must observe all warning signals and take care of their own and others' safety.
- All personnel should know their working tasks and procedures.
- Watch something like high voltage wire, unrelated personnel and poor ground for potential danger, and report to the operators and signalmen.

Duty of managers

- Ensure the operators are trained and fully understand the Operation and Maintenance Manual supplied by SANY. Ensure they are physically fit and have the certification of operation. Otherwise, it is forbidden to operate the roller.
- Ensure the operators have good judgement, teamwork consciousness and psychological quality. Otherwise, it is forbidden to operate or repair the roller.
- Ensure the signalmen have good vision and acoustic judgement, master standard command signals. At the same time, they should have enough experience in recognizing danger factors correctly, and inform the operators of danger factors to avoid them in time.
- Ensure assistant workers can identify the model and working condition to choose a proper roller.
- Publicize safety consciousness to working personnel, and make them aware of safety precautions and their related responsibilities.

Table of Contents

1 Introduction.....	1-1
1.1 Overview.....	1-3
1.2 Your Documentation Package.....	1-3
1.2.1 Introduction.....	1-3
1.2.2 Recommendations on Using the Documentation	1-4
1.2.3 Documentation Storage.....	1-4
1.2.4 Organization of This Manual.....	1-4
1.3 Your SANY Equipment	1-5
1.3.1 Equipment Directions.....	1-5
1.3.2 Breaking in a New Equipment	1-5
1.3.3 Equipment Information	1-6
1.3.4 Serial Number and Distributor Information	1-7
1.4 Contact Information	1-8
1.5 Abbreviations	1-8
1.6 Glossary	1-8
1.7 Declaration of Conformity	1-9
2 Safety.....	2-1
2.1 General	2-3
2.1.1 Introduction.....	2-3
2.1.2 Intended Use	2-4
2.1.3 Unintended Use	2-5
2.1.4 Qualifications of Operators and Maintenance Personnel.....	2-5
2.1.5 Unauthorized Modification	2-5
2.2 Safety Message.....	2-5
2.2.1 Introduction.....	2-5
2.2.2 Safety Message Introduction	2-6
2.2.3 Safety Alerts	2-6
2.2.4 An Example of Safety Alerts	2-7
2.2.5 Safety Decals Locations.....	2-8
2.2.6 Safety Decals	2-8
2.3 General Precautions.....	2-21
2.3.1 Safety Rules	2-21
2.3.2 Abnormal Case	2-22
2.3.3 Potential Risks	2-22
2.3.4 Safety Devices	2-22
2.3.5 Personal Protective Equipment.....	2-22

2.3.6 Precautions against Emergency	2-25
2.4 Precautions During Operation	2-28
2.4.1 Safe Starting	2-28
2.4.2 Safe Operation	2-31
2.4.3 Safe Parking	2-36
2.5 Maintenance Precautions	2-37
2.5.1 Basic Rules	2-37
2.5.2 Lockout/Tagout Procedures	2-38
2.5.3 Working Area Preparation	2-39
2.5.4 Washing the Equipment	2-39
2.5.5 Self-Preparation	2-40
2.5.6 Proper Tool	2-40
2.5.7 Maintenance with Engine Running	2-41
2.5.8 Working under the Roller	2-42
2.5.9 Working in Noisy Environment	2-42
2.5.10 Removing Paint before Welding or Heating	2-42
2.5.11 Correct Welding	2-43
2.5.12 No Heating beside Hydraulic Pipeline	2-44
2.5.13 No Heating the Pipes with Combustible Liquid	2-44
2.5.14 Correctly Operating the Hydraulic System	2-44
2.5.15 Being Aware of High-Pressure Liquid	2-45
2.5.16 Regularly Replacing the Rubber Hoses	2-45
2.5.17 Avoiding Scald by High-Temperature Liquid	2-46
2.5.18 Preventing Battery from Explosion	2-46
2.5.19 Preventing Components from Flying out	2-47
2.5.20 Safe Storage of Parts	2-48
2.5.21 Safe Treatment of Liquid	2-48
2.5.22 Safe Treatment of Chemicals	2-48
2.5.23 Proper Disposal of Wastes	2-49
2.6 Safe Transportation	2-49
2.6.1 Load/Unload the Roller	2-49
2.6.2 Transport the Roller	2-50
2.6.3 Lift the Roller	2-51
3 System Function	3-1
3.1 Exterior Components	3-3
3.2 Control Console	3-3
3.3 Display	3-13
3.4 A/C Panel	3-22
3.5 Radio	3-24

4 Operation	4-1
4.1 Check before Starting the Engine.....	4-3
4.1.1 Inspection (Walk-around).....	4-3
4.1.2 Inspection before Starting.....	4-3
4.2 Adjustments Prior to Startup.....	4-6
4.2.1 Seat Adjustment.....	4-6
4.2.2 Rearview Mirror Adjustment.....	4-11
4.3 Equipment Check Prior to Startup.....	4-11
4.3.1 Introduction.....	4-11
4.3.2 Power on the Control System.....	4-12
4.3.3 Check the Fuel Level.....	4-12
4.3.4 Check the Diesel Exhaust Fluid (DEF) Level.....	4-13
4.3.5 Check the Propel Control Lever.....	4-13
4.3.6 Check the Emergency Stop Switch.....	4-13
4.3.7 Check the Parking Brake Switch.....	4-14
4.3.8 Check the Switches.....	4-14
4.4 Engine Starting.....	4-15
4.4.1 Normal Start.....	4-15
4.4.2 Jump-Start.....	4-16
4.4.3 Engine Start in Cold Weather (Optional).....	4-16
4.5 After Engine Starting.....	4-17
4.6 Test Running.....	4-17
4.7 Travel Operation.....	4-18
4.7.1 Travel Forward.....	4-18
4.7.2 Travel Backward.....	4-18
4.8 Vibration Operation.....	4-19
4.9 Parking Operation.....	4-21
4.9.1 Service Brake.....	4-21
4.9.2 Park Brake.....	4-21
4.9.3 Emergency Brake.....	4-22
4.10 Correct Driving According to the Road Condition.....	4-23
4.10.1 Working near Ditch Edge and Road Shoulder.....	4-23
4.10.2 Working near Buildings Vulnerable to Vibration.....	4-24
4.10.3 Working on the Slope.....	4-24
4.11 Check after Each Work Day.....	4-25
4.12 Transportation.....	4-25
4.12.1 Transport Vehicle.....	4-25
4.12.2 Using a Slope.....	4-25
4.12.3 Shipping.....	4-26
4.12.4 Towing Information.....	4-31

5 Maintenance	5-1
5.1 Maintenance Information	5-3
5.1.1 Introduction	5-3
5.1.2 Checks before Maintenance	5-3
5.1.3 Checks after Maintenance or Repairs	5-3
5.1.4 Notes on Maintenance	5-4
5.1.5 Notes on Fuel System	5-4
5.1.6 Notes on Engine Performance	5-5
5.1.7 Notes on Hydraulic System	5-5
5.1.8 Torque Values	5-5
5.2 Requirements on Use of Oil & Fluid	5-7
5.2.1 Introduction of Functional Oil & Fluids	5-7
5.2.2 Oil & Fluids Selection	5-9
5.2.3 Filling Capacities	5-14
5.3 Test Run Instructions	5-15
5.4 Maintenance Schedules	5-16
5.4.1 Introduction	5-16
5.4.2 Roller Maintenance Locations	5-16
5.4.3 Routine Maintenance	5-17
5.4.4 Engine–Store	5-18
5.4.5 Short-time Storage–Maintain	5-19
5.4.6 Long-time Storage–Maintain	5-19
5.4.7 Post-maintenance Roller–Check	5-19
5.4.8 Regular Technical Maintenance Intervals	5-20
5.5 Maintenance for the Power System	5-22
5.5.1 Air Filter–Clean/Replace	5-22
5.5.2 Engine Oil–Check/Refill/Change	5-26
5.5.3 Engine Oil Filter Element–Replace	5-29
5.5.4 Oil Water Separator–Check/Drain/Replace	5-29
5.5.5 Radiator–Check/Clean	5-33
5.5.6 Engine Coolant–Check/Change	5-34
5.5.7 Engine Belt–Check/Replace	5-36
5.5.8 Engine Air Intake Pipeline–Check	5-36
5.5.9 Fuel–Check/Refill/Replace	5-37
5.5.10 Fuel Filter–Replace	5-39
5.5.11 Crankcase Vent Line–Check	5-40
5.5.12 Aftertreatment System - Check/Fill	5-40
5.6 Maintenance for the Hydraulic System	5-41
5.6.1 Hydraulic Oil–Check/Refill/Change	5-41
5.6.2 Hydraulic Oil Filter–Replace	5-44
5.7 Maintenance for the A/C	5-45

5.7.1 A/C-Check/Maintain	5-45
5.7.2 Compressor V-belt-Check/Replace	5-48
5.8 Maintenance for the Electric System.....	5-49
5.8.1 Battery-Maintain.....	5-49
5.8.2 Electric Box-Maintain	5-51
5.8.3 Fuse-Replace.....	5-52
5.9 Maintenance for the Mechanical System.....	5-53
5.9.1 Grease for Propel Bearing-Fill	5-53
5.9.2 Grease for Central Articulation Frame-Fill	5-54
5.9.3 Lubricant for Drum Vibration Bearing-Replace	5-54
5.9.4 Lubricant for Reducer-Replace	5-55
5.9.5 Lubricant for Rear Axle-Replace	5-56
5.9.6 Damper-Check/Replace	5-57
5.9.7 Windshield Washer Fluid-Check/Fill.....	5-57
5.9.8 Oil tank and Pipes-Check.....	5-58
6 Troubleshooting	6-1
6.1 Mechanical Parts.....	6-3
6.1.1 Engine	6-3
6.1.2 Vibratory Drum.....	6-4
6.1.3 Propel System.....	6-5
6.2 Electrical Parts.....	6-5
6.2.1 Basic Electrical System	6-5
6.2.2 Electrical System of Working Devices.....	6-6
6.3 Air Conditioning System.....	6-6
7 Specification.....	7-1
7.1 Dimension of the Equipment	7-3
7.2 Specifications of the Equipment.....	7-4
8 Optional Configuration	8-1
8.1 Removable Padfoot	8-3
9 Disposal	9-1
9.1 Disposal of Product.....	9-3

(This section contains multiple horizontal dashed lines for the table of contents entries.)



SANY

Introduction

1.1 Overview.....	1-3
1.2 Your Documentation Package.....	1-3
1.2.1 Introduction	1-3
1.2.2 Recommendations on Using the Documentation.....	1-4
1.2.3 Documentation Storage	1-4
1.2.4 Organization of This Manual.....	1-4
1.3 Your SANY Equipment.....	1-5
1.3.1 Equipment Directions	1-5
1.3.2 Breaking in a New Equipment.....	1-5
1.3.3 Equipment Information	1-6
1.3.4 Serial Number and Distributor Information.....	1-7
1.4 Contact Information	1-8
1.5 Abbreviations	1-8
1.6 Glossary	1-8
1.7 Declaration of Conformity	1-9

1.Introduction

1.1 Overview

- SANY-built equipment offers high-quality performance and excellent after-sales service support.
- SANY-built equipment is widely used throughout the industry for various types of applications.
- SANY is a leading manufacturer of heavy construction equipment worldwide.

This operator's manual provides safety, operation, maintenance, troubleshooting and specifications. In order to correctly use your equipment, it is important to read and understand this manual before using the equipment.

Items addressed in this manual are designed to help you:

- Understand the structure and performance of your equipment.
- Reduce improper operation and point out possible hazardous situations when using equipment.
- Increase equipment efficiency during operation.
- Prolong the service life of your equipment.
- Reduce maintenance costs.

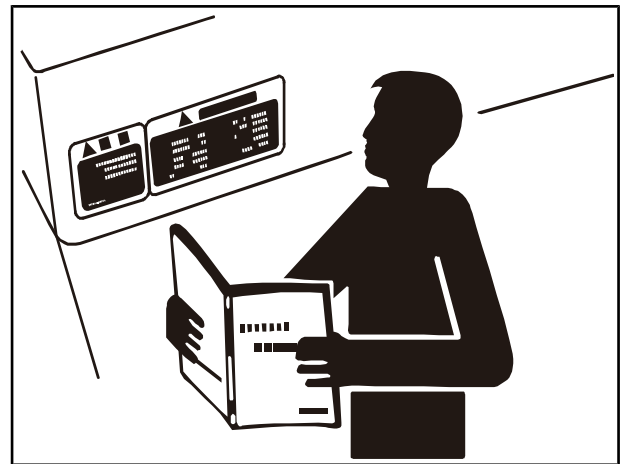

Fig 1-1

Always keep this manual nearby and have all personnel involved with any work operations read it periodically. If this manual becomes damaged or lost and cannot be read, it is advised to request a replacement copy from your SANY distributor as soon as possible. If you sell the equipment, be sure to give this manual to the new owner. Continuing improvements in the design can lead to changes in details which may not be reflected in this manual. Always consult your SANY distributor for the latest available information on your equipment or if you have questions regarding information in this manual.

1.2 Your Documentation Package

1.2.1 Introduction

The documentation includes:

- Safety, Operation and Maintenance Manual.
- Parts Book— including the Parts List and the Drawings needed when ordering parts. If the Parts Book is not attached with the equipment, contact SANY.

1.2.2 Recommendations on Using the Documentation

- The documents only apply to this equipment, and should not be used with any other equipments.
- Ensure that the documents are complete and up to date.
- Put all data in a folder (if including leaflets).
- Print and replace the lost, damaged and blotted pages.
- Add the latest SANY data in time and destroy the inapplicable old documents.

1.2.3 Documentation Storage

- Always keep the *Operation and Maintenance Manual* in the net pocket behind the operator cabin's seat.
- The *Parts Book* is best left either shelved in the workshop area or office. It should always be available to the maintenance and service personnel as required.

1.2.4 Organization of This Manual

This operator's manual covers operation and maintenance of your equipment. Get familiar with it before performing any operations. Put this manual within easy reach for your reference and replace it if it is lost or damaged. Due to improvement and update of products, some information may differ for your equipment. If you have any question on the use and maintenance of your equipment, contact your SANY distributor.

1. Introduction

This section provides an overview of what is covered in the rest of this manual, including equipment label information and SANY contact information.

2. Safety

This section covers basic safety information related to this equipment. Make sure you fully understand all the precautions described in this manual and the safety decals on the equipment before operating or maintaining this equipment. Failure to do so may result in serious injury or death.

3. System functions

This section provides an overview of all the controls and prompt & operating systems on your equipment. Only when you are familiar with all systems, can you operate and maintain the equipment safely.

4. Operation

This section provides the basic operating procedures for the equipment. It is important to study and become familiar with all procedures before performing any operations with the equipment.

5. Maintenance

This section provides all general maintenance and repair procedures. It is important to study and become familiar with all the maintenance and repair procedures before performing any maintenance or repair operations on the equipment.

6. Troubleshooting

This section includes common malfunctions and fault diagnostic procedures for the operating system of this single drum roller. The basic troubleshooting methods for mechanical, hydraulic and electrical systems are included.

7. Specifications

This section provides the general information about this equipment. Some information may change due to design modification.

8. Disposal

This section provides the suggestions and precautions on the disposal of the machine when removed from service.

1.3 Your SANY Equipment

1.3.1 Equipment Directions

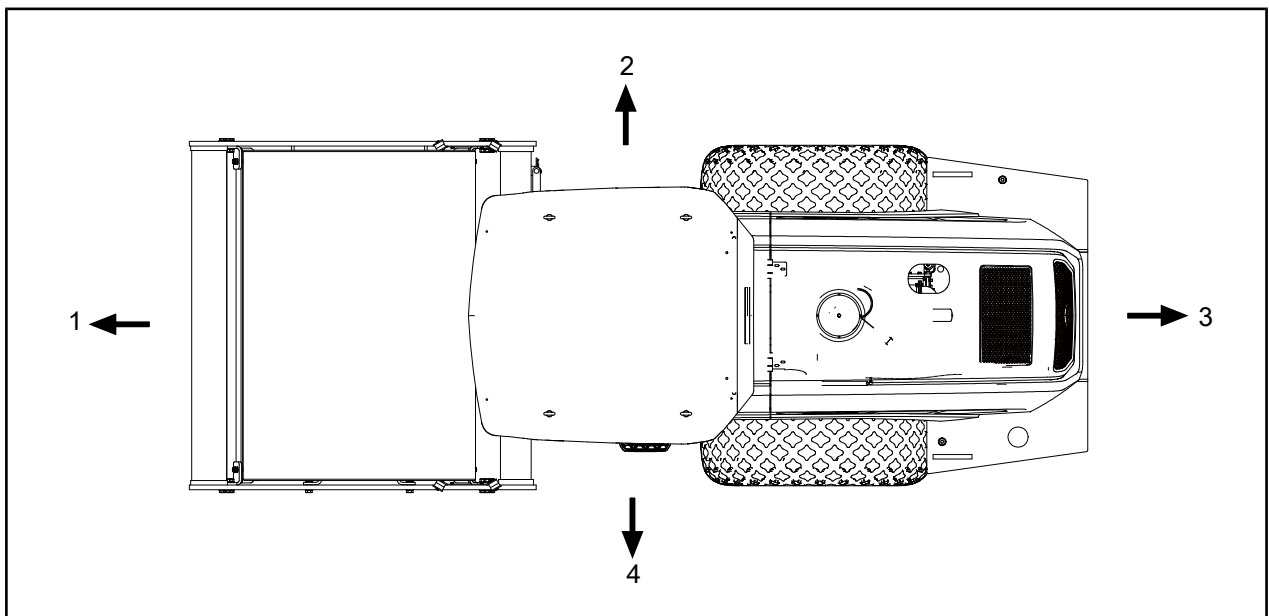

Fig 1-2

1. Front

2. Right

3. Back

4. Left

1.3.2 Breaking in a New Equipment

Your equipment has been well adjusted and tested before delivery. However, initial operation on the equipment in severe conditions will seriously affect the performance or reduce the service life

of the equipment. Thus SANY recommends you to perform 100 hour test run before putting the equipment into production use.

During the break-in period:

- Let the equipment warm up prior to any operation.
- Avoid operating or running the equipment at a high speed in overload working conditions.
- Avoid sudden starting, rapid movement or abrupt stop of the equipment.
- Cool down the equipment system at the end of every working day.

1.3.3 Equipment Information

The serial numbers and model numbers on the components are the only numbers that your SANY distributor will need when ordering replacement parts or requiring assistance for your equipment. You can find the related information on the data plate. It is a good idea to record this information in this manual for future use.

Product identification plate is riveted on the left side of the rear frame.

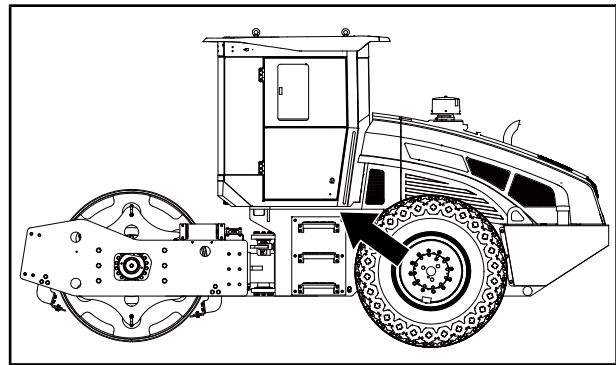

Fig 1-3

1.3.4 Serial Number and Distributor Information

This location is for you to record information relating to your equipment. It is advised that you keep this manual with your equipment at all times for reference.

Product Type	
Serial No.	
Date of Production	
Vehicle Identification Number (VIN)	
Distributor Name:	
Address:	
Phone Numbers:	

1.4 Contact Information

Thank you for purchasing a SANY product. If you need to contact us for any reason, you can reach us as follows:

Sany Europe GmbH

Sany Allee 1

50181 Bedburg

Germany

www.sanyeurope.com

nfo@sanyeurope.com

Tel.: +49 2272 90531 100

1.5 Abbreviations

- GPS – Global positioning system
- ISO – International Organization for Standardization
- A/C – Air condition
- rpm – Revolutions per minutes
- MIN – Minimum
- MAX – Maximum
- OAT –Organic Acid Technology

1.6 Glossary

- Single Drum Roller–A machine with one vibratory drum.
- Serial Number – Unique machine designation. On machine nameplate.
- Refrigerant – The intermediary substance used in various heat engines to complete energy conversion
- Cab – The small cabin where the operator stays in and control the equipment.

1.7 Declaration of Conformity

This machine has passed the CE certification.

The Declaration of Conformity specifies the applicable directives and standards. This Declaration of Conformity is only valid when this machine meets the directives and standards stated in this Declaration of Conformity.

SANY Europe GmbH	Original	2006/42/EC , II A
1 DE EG-Konformitätserklärung im Sinne der EG-Richtlinie 2006/42/EG über Maschinen (Anhang II A) GB Declaration of Conformity according to EC directive 2006/42/EC on machinery (Annex II A) FR Déclaration de conformité CE conformément à la directive 2006/42/CE sur les machines (Annexe II A)		
2 DE Name und Anschrift des Herstellers: GB Name and address of the manufacturer: FR Nom et adresse du fabricant:	Sany Automobile manufacturing Co.,Ltd Sany Industry Town, Kingsha Development Zone, Changsha, 410100 Hunan, P.R. China	
3 DE Name und Anschrift des Bevollmächtigten: GB Name and address of the authorised representative: FR Nom et adresse du mandataire,	SANY Europe GmbH Sany Allee 1 D-50181 Bedburg	
4 DE Bevollmächtigter für die Zusammenstellung der relevanten technischen Unterlagen: GB Authorized Body to compile the relevant technical file: FR Mandataire pour la constitution des documents techniques nécessaires;	SANY Europe GmbH Sany Allee 1 D-50181 Bedburg	
5 DE Hiermit erklären wir, dass die nachstehend beschriebene Maschine - Bezeichnung/ Typ / Maschinennummer GB Herewith we declare, that the machinery described below - Designation/ Model/ Serial-No. FR Nous déclarons par la présente que la machine décrite ci-dessous, Désignation, Type, Numéro de série.		
6 DE Walzenzug GB Single Drum Roller FR Rouleau à tambour unique	SSR130C-10H	
7 DE allen einschlägigen Bestimmungen der Maschinenrichtlinie entspricht. GB is complying with all essential requirements of the Machinery Directive FR est conforme à toutes les dispositions applicables de la Directive sur les machines,		2006/42/EC
8 DE Es wird die Übereinstimmung mit weiteren, ebenfalls für die Maschine geltenden Richtlinien erklärt: GB It will explain the accordance with further directives, which also apply to the machine: FR La machine est également en conformité avec les directives suivantes:		
9 DE Geräuschemissionen GB Outdoor Directive FR Matériels utilisés à l'extérieur	2000/14/EC	Schalleistungspegel Sound power level Niveau de puissance sonore L _{WA} = 108dB
10 DE EMV-Richtlinie GB EMC Directive FR Directive Électromagnétique	2014/30/EU	11 DE Emissionsrichtlinie GB Directive emission of pollutants FR Émissions de particules polluants
12 DE Angewandte harmonisierte Normen: GB Used harmonised standards: FR Normes harmonisées utilisées:		
13 EN 500-1:2006+A1	DE Straßenbaumaschinen - Sicherheit - Teil 1: Allgemeine Anforderungen GB Mobile road construction machinery - Safety - Part 1: General requirements FR Machines mobiles de construction routière - sécurité - Partie 1 : exigences générales	
14 EN 500-4:2011	DE Straßenbaumaschinen - Sicherheit - Teil 4: Besondere Anforderungen an Verdichtungsmaschinen GB Mobile road construction machinery - Safety - Part 4: Specific requirements for compaction machines FR Machines mobiles de construction routière - sécurité - Partie 4 : Exigences spécifiques pour les machines de compactage	
15 DE Datum: GB Date: FR Date:	Geschäftsführer Managing Director Directeur général	Jiang Nan

Fig 1-4 Declaration of Conformity

SANY

Safety

2 Safety	2-1
2.1 General	2-3
2.1.1 Introduction	2-3
2.1.2 Intended Use	2-4
2.1.3 Unintended Use	2-5
2.1.4 Qualifications of Operators and Maintenance Personnel	2-5
2.1.5 Unauthorized Modification	2-5
2.2 Safety Message	2-5
2.2.1 Introduction	2-5
2.2.2 Safety Message Introduction	2-6
2.2.3 Safety Alerts	2-6
2.2.4 An Example of Safety Alerts	2-7
2.2.5 Safety Decals Locations	2-8
2.2.6 Safety Decals	2-8
2.3 General Precautions	2-21
2.3.1 Safety Rules	2-21
2.3.2 Abnormal Case	2-22
2.3.3 Potential Risks	2-22
2.3.4 Safety Devices	2-22
2.3.5 Personal Protective Equipment	2-22
2.3.6 Precautions against Emergency	2-25
2.4 Precautions During Operation	2-28
2.4.1 Safe Starting	2-28
2.4.2 Safe Operation	2-31
2.4.3 Safe Parking	2-36
2.5 Maintenance Precautions	2-37
2.5.1 Basic Rules	2-37
2.5.2 Lockout/Tagout Procedures	2-38
2.5.3 Working Area Preparation	2-39

2.5.4 Washing the Equipment	2-39
2.5.5 Self-Preparation	2-40
2.5.6 Proper Tool	2-40
2.5.7 Maintenance with Engine Running	2-41
2.5.8 Working under the Roller	2-42
2.5.9 Working in Noisy Environment	2-42
2.5.10 Removing Paint before Welding or Heating	2-42
2.5.11 Correct Welding	2-43
2.5.12 No Heating beside Hydraulic Pipeline	2-44
2.5.13 No Heating the Pipes with Combustible Liquid	2-44
2.5.14 Correctly Operating the Hydraulic System	2-44
2.5.15 Being Aware of High-Pressure Liquid	2-45
2.5.16 Regularly Replacing the Rubber Hoses	2-45
2.5.17 Avoiding Scald by High-Temperature Liquid	2-46
2.5.18 Preventing Battery from Explosion	2-46
2.5.19 Preventing Components from Flying out	2-47
2.5.20 Safe Storage of Parts	2-48
2.5.21 Safe Treatment of Liquid	2-48
2.5.22 Safe Treatment of Chemicals	2-48
2.5.23 Proper Disposal of Wastes	2-49
2.6 Safe Transportation	2-49
2.6.1 Load/Unload the Roller	2-49
2.6.2 Transport the Roller	2-50
2.6.3 Lift the Roller	2-51

2.Safety

2.1 General

2.1.1 Introduction

This *Operation and Maintenance Manual* is a guide for you to operate your equipment correctly.

It contains technical and safety information necessary for operation of your equipment. Read and understand each section of the manual.

Always operate your equipment according to national, provincial, prefectural and municipal laws and regulations.

SANY cannot anticipate every possible circumstance that can involve a potential risk during operation and maintenance. The safety messages in this manual and on the product are, therefore, not all inclusive. If a procedure, work method or operating technique that is not specifically recommended in this manual is used, you must be sure that it is safe for you and for others. You should also make sure that the product will not be damaged or be made unsafe by the operation, lubrication, maintenance or repair procedures that you select.

Equipment covered by this manual is used for various operations under normal conditions.

Never use the equipment in the flammable or explosive environment, or in areas containing asbestos dust.

Select a SANY tandem roller with a configuration suitable for high-plateau operation when operating in areas 2000 meters above the sea level.

The information, specifications, and illustrations in this publication are on the basis of information that was available at the time when the publication was written. SANY reserves the right to change these information at any time without prior notice. Consult SANY distributor to obtain the latest information or if you have any question on the information provided in this manual.

Before starting operation and maintenance, operator and maintenance personnel shall observe the following items:

- Read and understand the whole manual.
- Read and understand the safety notices contained in this manual and the safety messages on the equipment.
- Never apply or operate your equipment under any circumstances in a manner that is not permitted in this manual.
- If the amount of fuel added, content of particulates, or latitude is beyond the specification of this type of equipment, damage could occur and the warranty of your equipment would become invalid.

The manual should be kept in the cabin all the time for operator to refer to at any time. Contact SANY distributor to obtain a new manual if the original one is missing or cannot be read.

This manual should be considered as a permanent component of your equipment. If the equipment is sold to a third party, give this manual to the new owner. The equipment provided by SANY Road Machinery Co., Ltd to its buyer is in line with all specifications and standards of buyer's country. If the equipment is purchased from another country or someone of a third country, it can lack some safety devices or technical requirements necessary for using the equipment in your country. In case you question whether the equipment is in accordance with the standards and specifications of your country, contact SANY distributor before operating the equipment.

2.1.2 Intended Use

The rollers with smooth vibratory drum are mainly designed for the following operations:

- Compacting different kinds of pavements, such as pebble, sandy soil, moraine soil blasting rock and cohesive soil.
- Compacting foundation materials such as concrete and stabilized soil in various large-scale projects.



Fig 2-1

- Compacting work on airports, ports, dams high-grade highways and other industrial construction sites.

NOTE :

It is not recommended to use rollers with welded or removable padfoot for compacting stone materials such as gravels, blasting rocks and the rockfill. Padfoots could wear or crack for such operation. All those consequences will be born by the user.

2.1.3 Unintended Use

- Operation by untrained personnel in an unprofessional manner or using the equipment for purposes unmentioned in this manual may pose hazard.
- Avoid starting vibration on asphalt pavement and pavement with thick ice.
- Avoid starting and operating the equipment in an explosive environment.

2.1.4 Qualifications of Operators and Maintenance Personnel

- The equipment can only be operated by trained and authorized persons who are at least 18 years old.
- The operator must fully understand and obey the operation rules of the equipment.
- Persons under the influence of alcohol, medication or drugs are not permitted to operate, service or repair the equipment.
- Only trained and qualified personnel can carry out maintenance and repair tasks of the equipment.



Fig 2-2

2.1.5 Unauthorized Modification

Any modification to the machine without authorization from SANY can have a bad effect on the machine's performance or pose more serious risks. Incorrect operation or unapproved application may lead to equipment failure, personal injury or possible death. SANY assumes no responsibility for such losses.

2.2 Safety Message**2.2.1 Introduction**

Safety decals and safety messages on the machine should be dealt with and arranged properly as following :

- Make sure that you get familiar with the locations and information of all safety decals on the machine.
- All warning decals must be placed in the proper locations on the machine. They must be kept clean for readability. Never use organic solvent or gasoline to clean the warning decals, which may cause the paints on the safety decal to fall.
- Other signs are also on the machine besides safety decals and safety messages, which must be kept clean and intact.
- Use a new safety decal or safety message in a timely manner to replace the old one which is damaged or missing.

2.2.2 Safety Message Introduction

For using the machine safely and properly, this manual has provided you with the detailed illustrations to the decals on the machine to make you be aware of potential hazards and prevent the hazards.

All operators or maintenance personnel involved with the use of this machine must read this manual thoroughly and fully understand the safety message on the machine prior to operating or maintaining this machine. Strictly observe the safety rules provided in this manual to avoid personal injury and damage to the machine.

2.2.3 Safety Alerts

The following safety alerts are used to inform you that there might be potential dangers which could lead to personal injury or damage.

In this manual and on the machine decals, different safety alerts or illustrations are used to express the potential level of hazard.

Table 2-1 Safety Alerts and Explanation







Safety Alerts	Explanation
	Indicates an imminent hazard which, if not avoided, will result in serious injury or death.
	Indicates a potential hazard which, if not avoided, could result in injury or possibly death.

Table 2-1 Safety Alerts and Explanation (continue)

Safety Alerts	Explanation
	<p>Indicates a possible potential hazard which, if not avoided, could result in minor or major injury.</p>
	<p>Indicates a situation which can cause damage to the equipment, personal property and/or the environment, or cause the equipment to operate incorrectly.</p>
	<p>This hazard alert symbol appears in most hazardous situation. It means attention and alert, because your safety is involved! Please read and obey the message that follows the hazard alert symbol.</p>
	<p>Indicates that if the operator disobeys the safety regulations, it might cause personal injury or death. And the operation on job-site is not permitted.</p>

2.2.4 An Example of Safety Alerts

NOTICE
<p>Risk of machine damage! Mixed use of different brands of oil could cause machine performance degradation or component failure. Never mix oil and fluids of different brands while using them.</p>

2.2.5 Safety Decals Locations

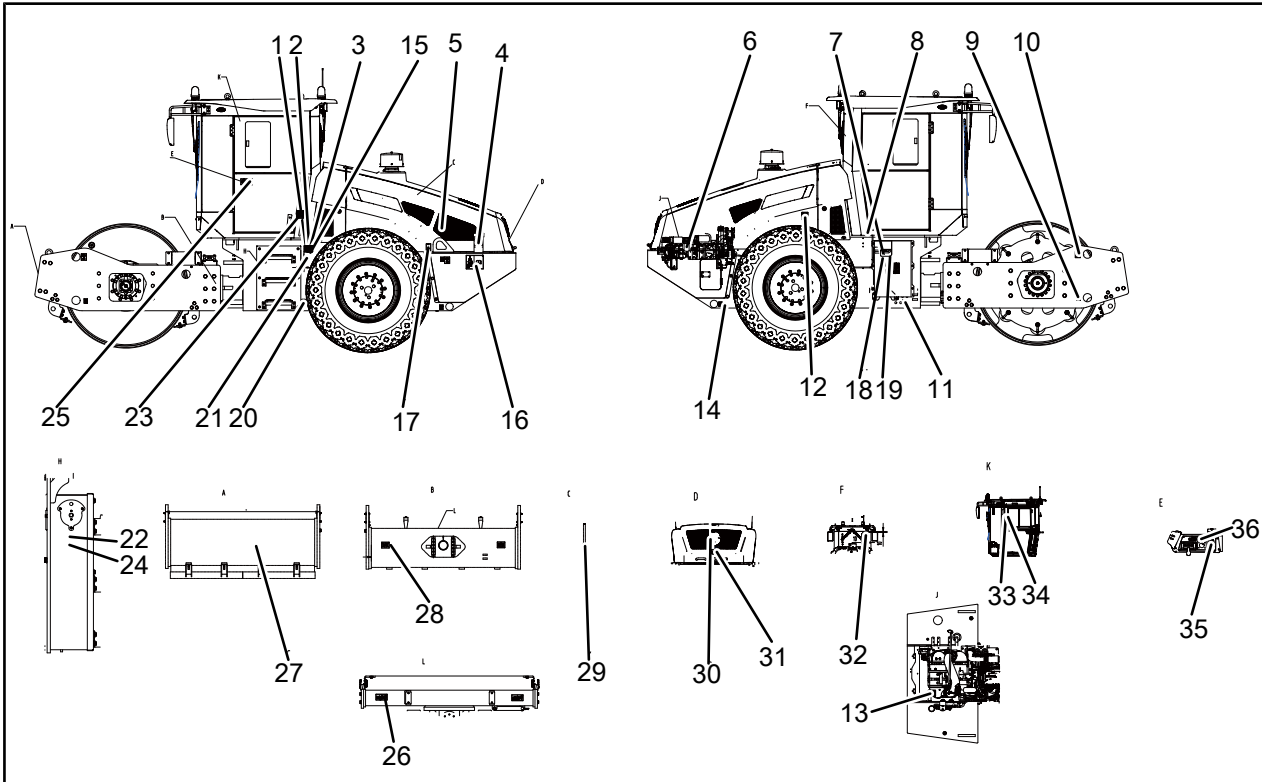

Fig 2-3

- | | | | |
|-------------------------|--------------------------|--------------------------|------------------------------|
| 1. Nameplate | 11. Engine oil outlet | 21. Tire pressure | 30. SANY logo |
| 2. Rivet | 12. Belt hazard | 22. POI indicator notice | 31. Hood lock |
| 3. Read the manual | 13. Caution for hot | 23. ROPS/FOPS nameplate | 32. Window escape |
| 4. Fuel quality | 14. Towing hook force | 24. Power switch | 33. Serial number QR code |
| 5. Filter element alarm | 15. Noise level | 25. Vibration caution | 34. My sany download QR code |
| 6. Hydraulic oil tank | 16. Hoisting instruction | 26. Caution for rolling | 35. Operation precaution |
| 7. Lubrication point | 17. Manual pump | 27. SANY logo | 36. Vibration button |
| 8. No right door access | 18. DEF filling point | 28. Keep away | |
| 9. Tie-down point | 19. DEF filling amount | 29. Don't touch | |
| 10. Hook point | 20. Coolant outlet | | |

2.2.6 Safety Decals

Safety decals are fixed to the equipment, which are used to alert local operator or maintenance workers that potential danger might be involved when operating or servicing the equipment.

The equipment uses "safety words" and "safety symbols" to indicate safety measures.

Safety Words

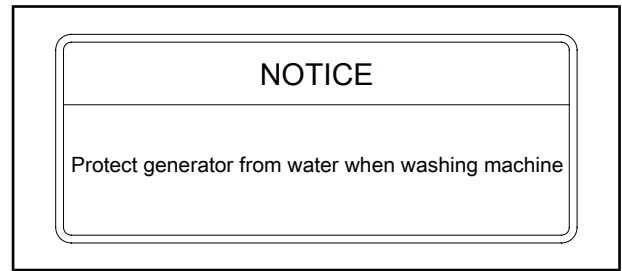

Fig 2-4

Safety Symbols

Safety symbol uses an image to indicate a hazardous situation that may occur during maintenance or operation, which make the operator or serviceman understand the type and level of a hazardous situation at any time. Only part of the safety symbols are shown here, see the machine for all the safety symbols.

- Nameplate

Show parameters about the machine.

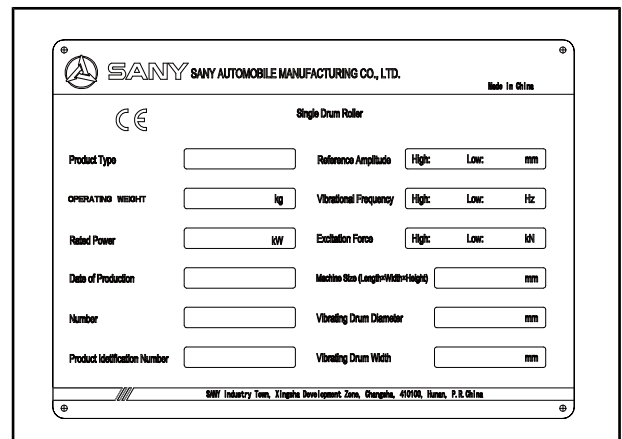

Fig 2-5

- Read the manual

Warns to read the appropriate section of this manual.

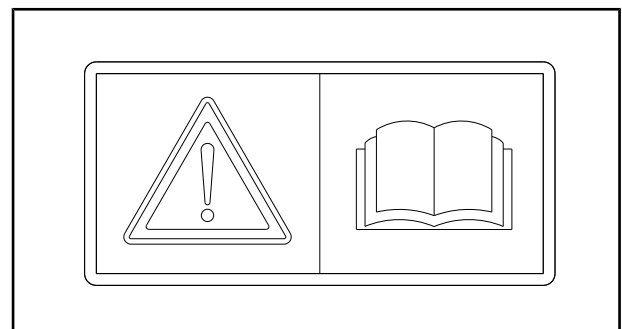

Fig 2-6

- Fuel quality

Specifies the quality of the fuel used for this machine.

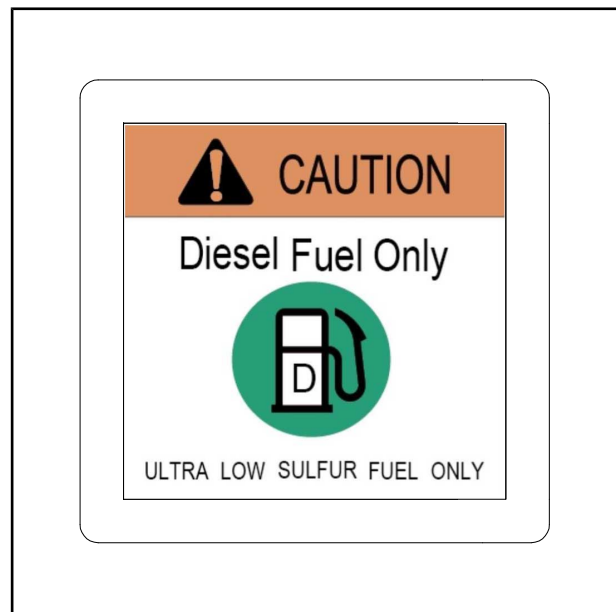

Fig 2-7

- Filter element alarm

Caution for the filter element.

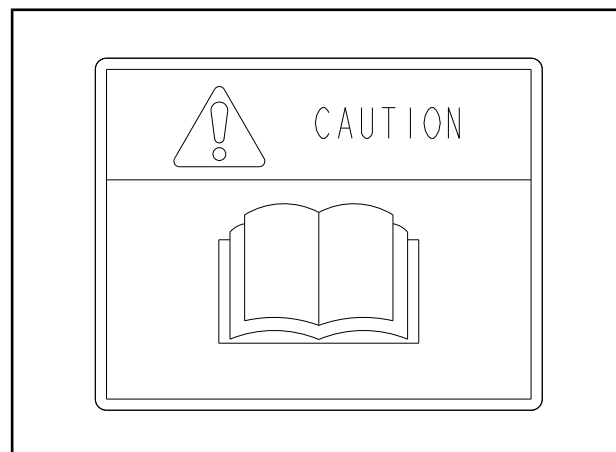

Fig 2-8

- Hydraulic oil tank

Identifies the location of the hydraulic oil tank and the selection of the hydraulic oil.

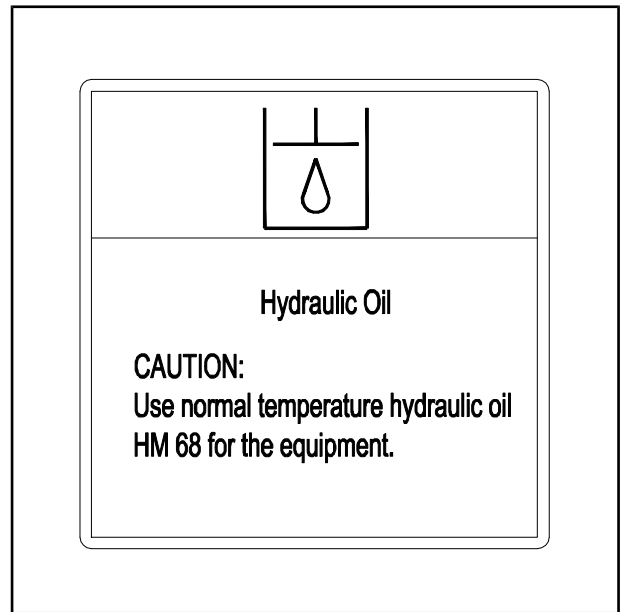

Fig 2-9

- Lubrication point

Identifies the location of the lubrication point and oil change intervals.

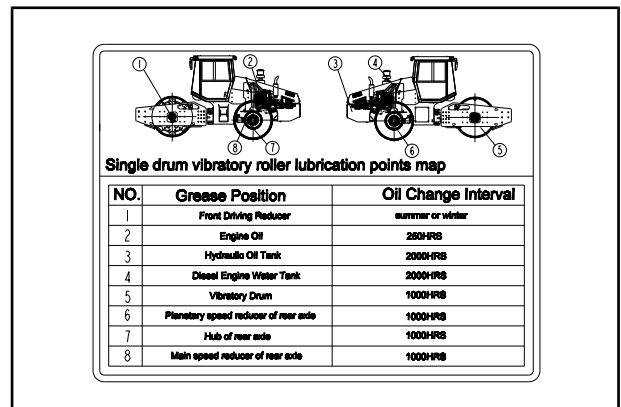

Fig 2-10

- No right door access

Do not enter the cab from the right door.

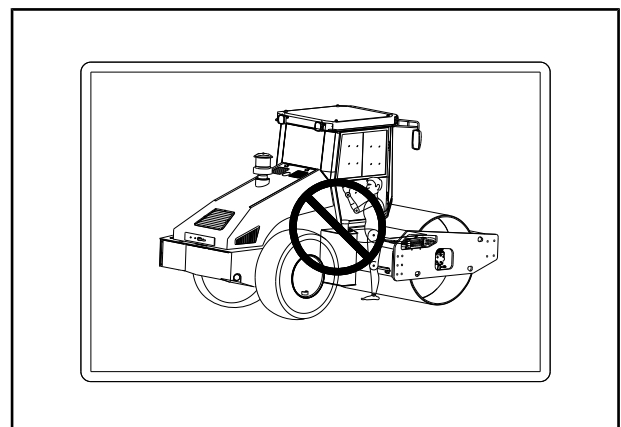

Fig 2-11

- Tie-down point

Identifies the location of the tie-down point.

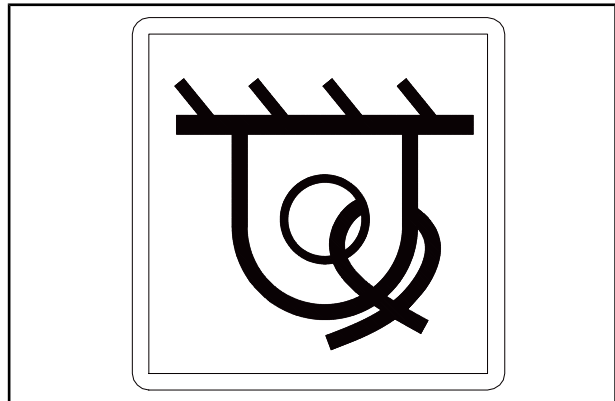

Fig 2-12

- Hook point

Identifies the location of the hook points.

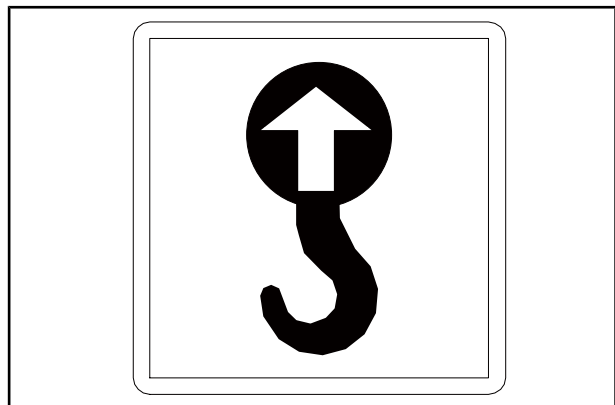

Fig 2-13

- Engine oil outlet

Show the location of engine oil outlet.

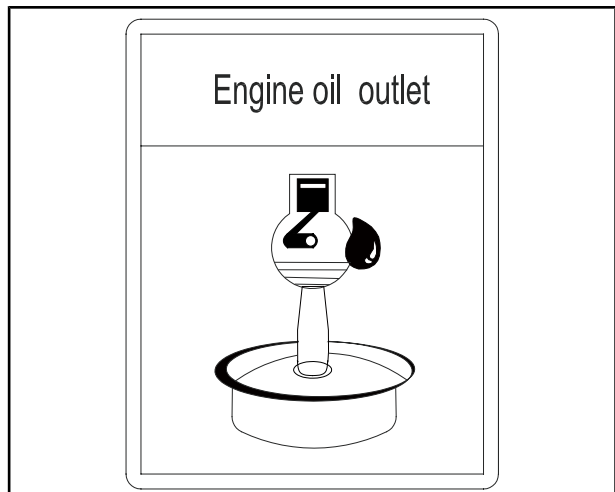

Fig 2-14

- Belt hazard

Warning for belt danger.



Fig 2-15

- Caution for hot

Hot surface can cause serious burns. Stop the engine and wait till the top of hood is cool.



Fig 2-16

- Towing hook force

Specifies the towing hook force.

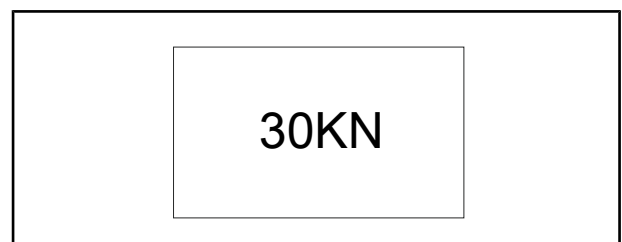

Fig 2-17

- Noise level

Show the noise level, which meets the CE requirement.

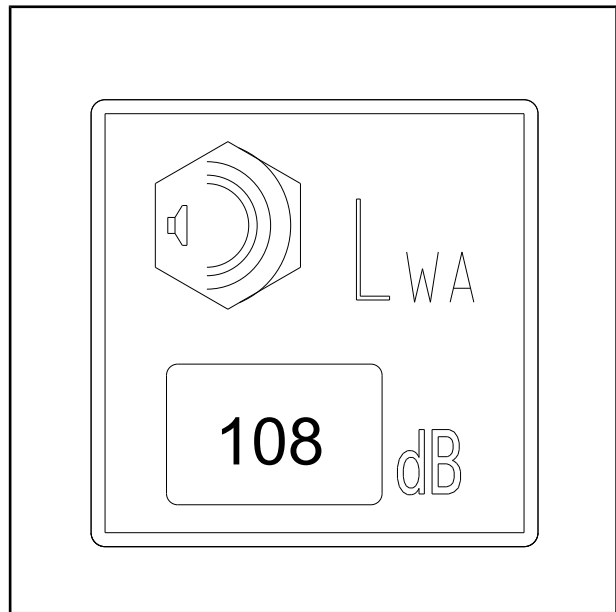

Fig 2-18

- Hoisting instruction

Instructs the hoisting.

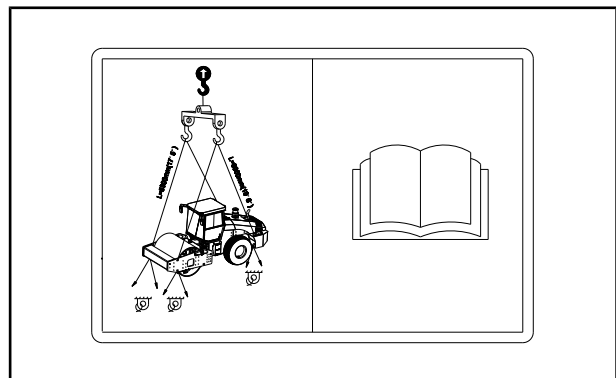

Fig 2-19

- Manual pump

Identifies the location of the manual pump.

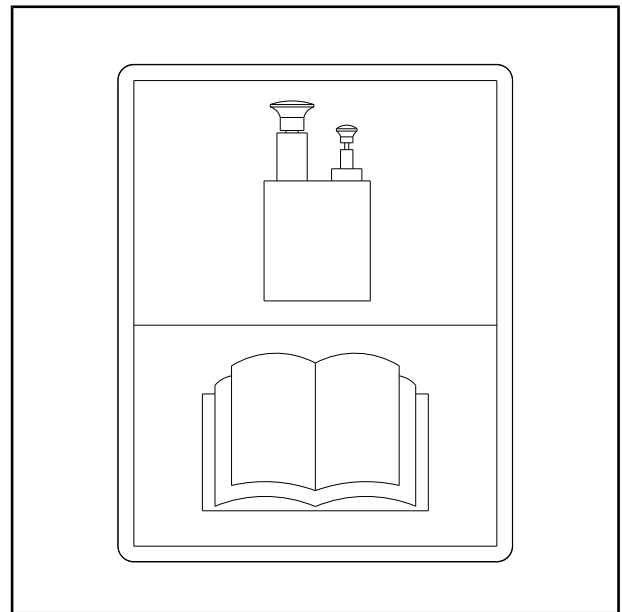

Fig 2-20

- DEF filling point

Identifies the location of the DEF filling point.

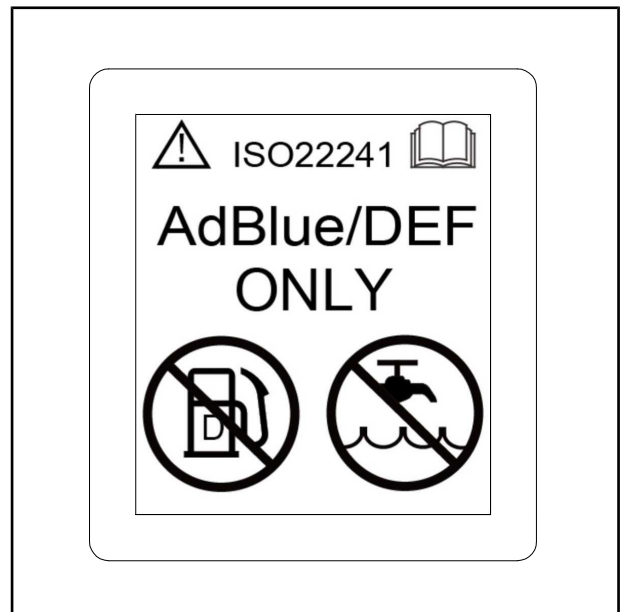

Fig 2-21

- DEF filling amount

Specifies the min DEF filling amount.

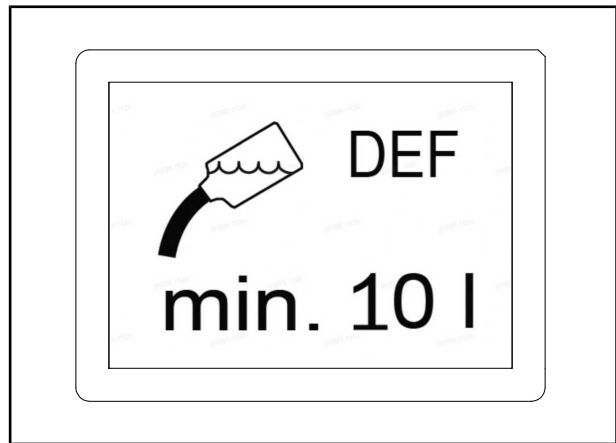

Fig 2-22

- Coolant outlet

Identifies the location of coolant outlet.

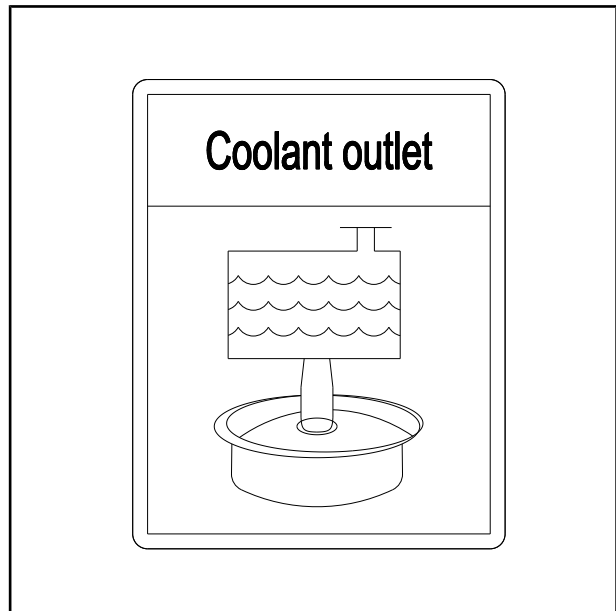

Fig 2-23

- Tire pressure

Charge the tire according to the specification of the tire.

		Tire Pressure
Type of tire	Pressure kgf/cm ² (bar)	
23.10-26 8PR	1.4±0.3	
14.90-24 8PR	1.5±0.3	
23.10-26 12PR	2.0±0.3	
23.10-26 14PR	2.3±0.3	
23.50-25 16PR	3.0±0.3	
20.50-25 16PR	3.5±0.3	
For more details, refer to the roller's Safety, Operation and Maintenance Manual.		

Fig 2-24

- POI indicator notice

Identifies the location of POI indicator.

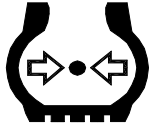
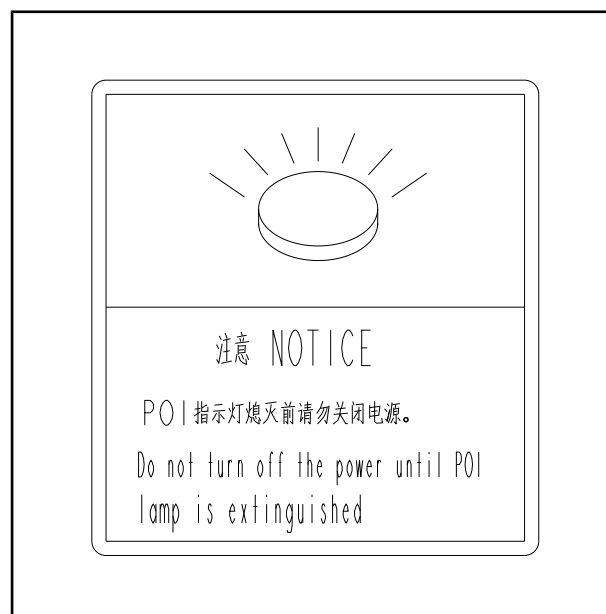

Fig 2-25

- Power switch notice

Turn off the main switch after the engine is off for 3 minutes.

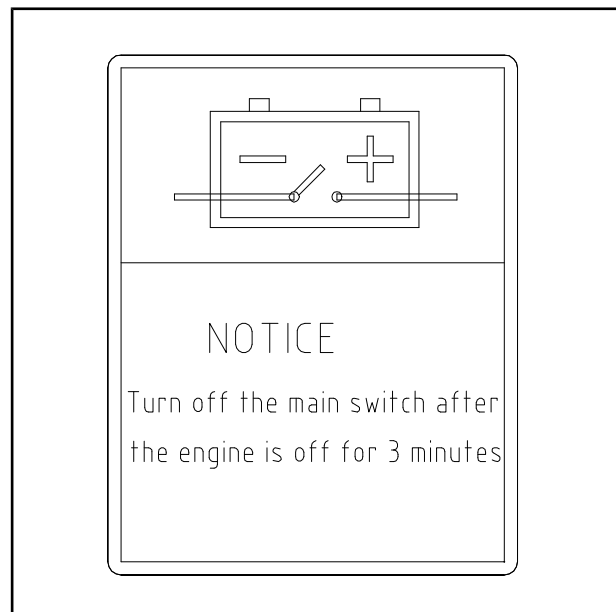

Fig 2-26

- Battery disconnect switch indication

Before starting the machine, turn the switch to the "ON" position. If the machine is to be stored for a long time, turn off the switch.

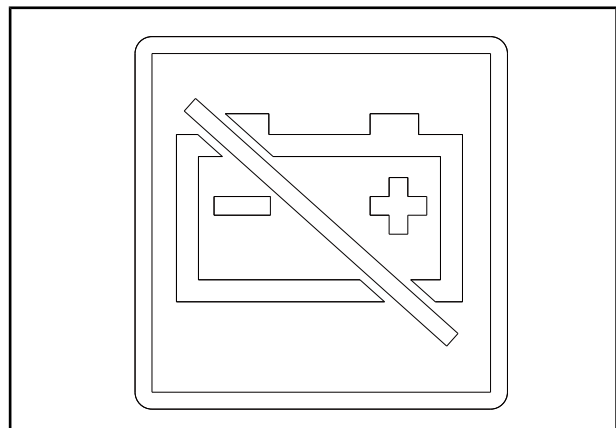

Fig 2-27

- Vibration caution

Prompts for vibration.

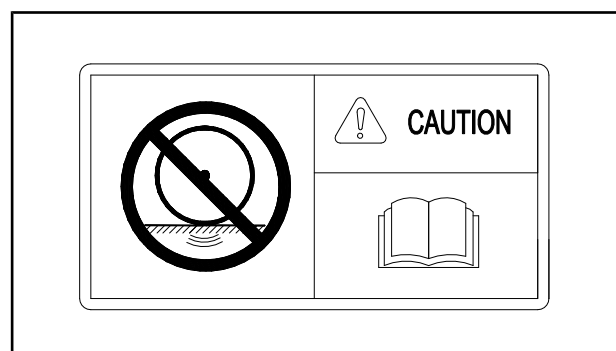

Fig 2-28

- Caution for rolling

Warning for rolling danger.

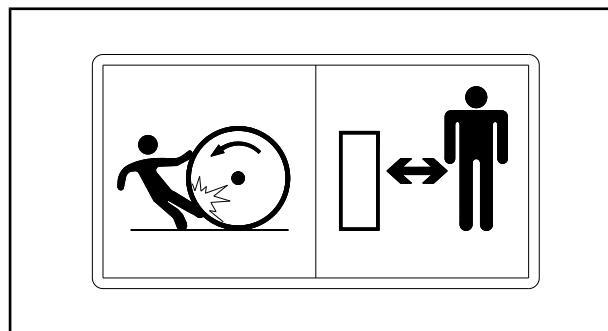

Fig 2-29

- Keep away

Keep away from the center articulation frame when the roller is working, otherwise you may be squeezed.

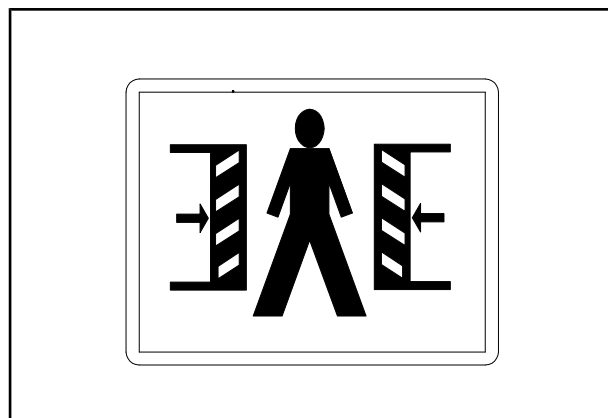

Fig 2-30

- Don't touch

Do not use it as handle.

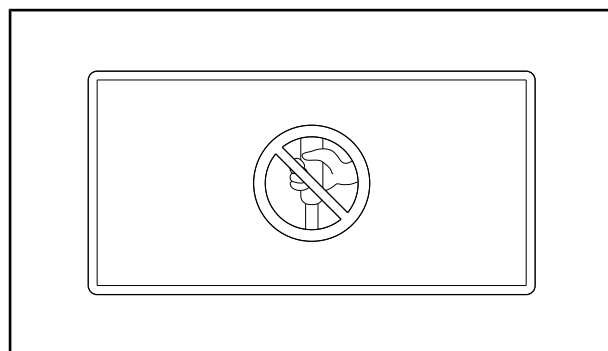

Fig 2-31

- Hood lock

Identifies the usage of the hood lock.

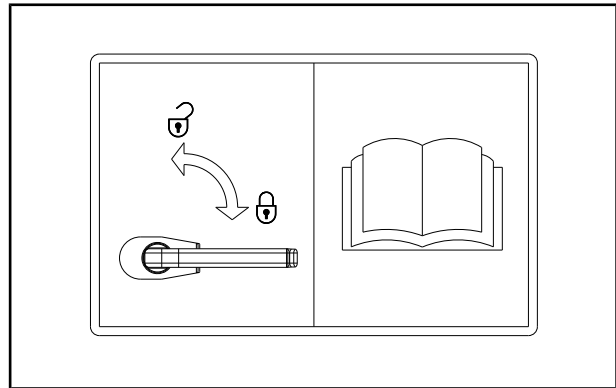

Fig 2-32

- Window escape

Identifies the window escape.

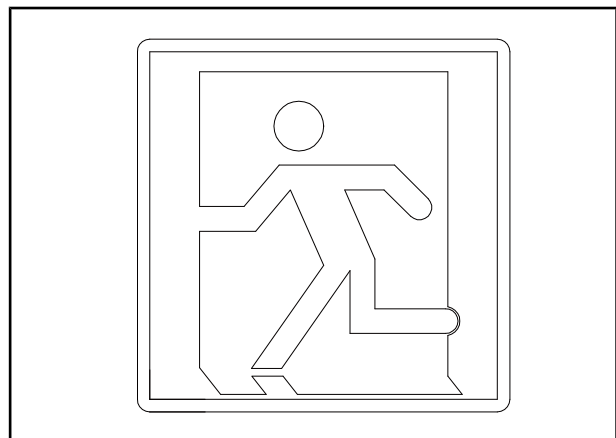

Fig 2-33

- ROPS/FOPS nameplate

Show information about the ROPS/FOPS cab.

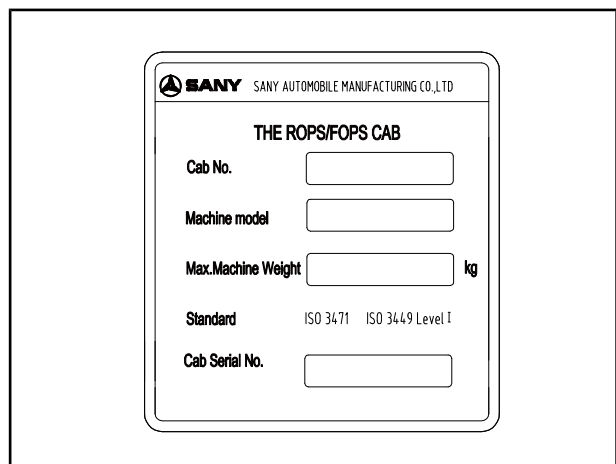

Fig 2-34

- Operation precaution

Explain the operation precautions.

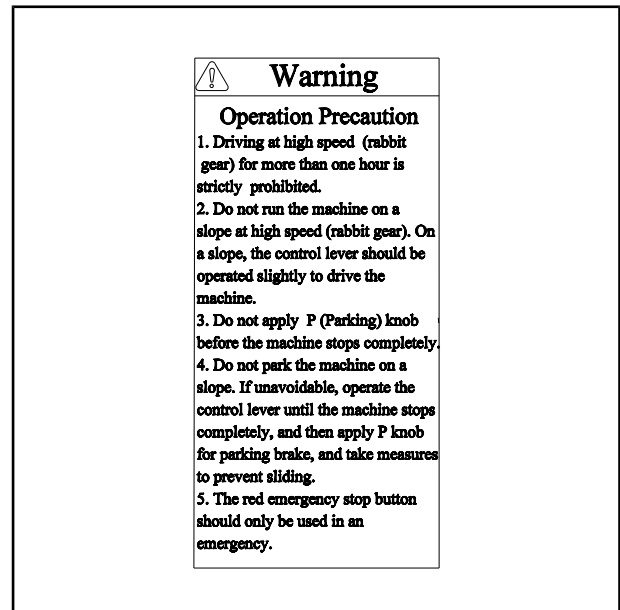

Fig 2-35

- Vibration button

Identifies the location of the vibration button.

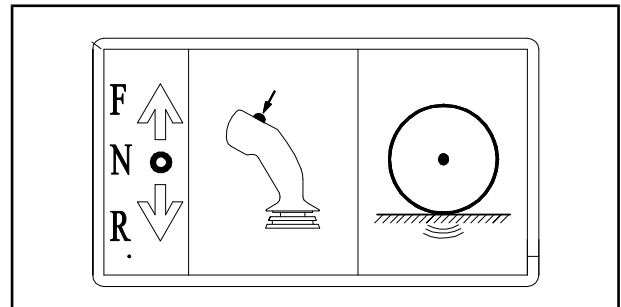

Fig 2-36

2.3 General Precautions

2.3.1 Safety Rules

- Only trained personnel are allowed to operate and service the equipment.
- Never operate the roller that has fault.
- Never operate the roller in a hazardous situation.
- All safety rules, precautions and instructions must be followed when operating and servicing the equipment.
- Taking alcohol or drug could seriously impair one's ability in operating or repairing the equipment, and it is hazardous for you and other persons.
- When working with another operator or traffic signalman on the worksite, be sure to make all people understand all gestures to be used.

2.3.2 Abnormal Case

In case of any abnormalities found during operation and maintenance, such as noise, odor, incorrect gauge display, smoke, or oil leakage, you are obligated to inform your boss and take necessary measures. Never operate the equipment before the faults are eliminated.

2.3.3 Potential Risks

Always operate the machine accordance with standards and regulations. However, potential risks can still not be completely ruled out. So, special attention should be paid when working with the machine, so that you can react immediately in case of a possible malfunction, an incident or failure etc.

2.3.4 Safety Devices

To protect yourself and others around you, your roller may be equipped with the following safety devices. See that each item is securely in place and in operating condition.

- Headlights, rear lights, turn lights
- Alert lights
- Rearview mirror
- Windshield wipers & washers
- Horn
- Safety decals

2.3.5 Personal Protective Equipment

Read and understand the following:

- If the machine is equipped with operator aids, Occupational Safety and Health Administration (OSHA) requires this equipment to be used when operating the machine.
- Avoid any loose fitting clothing, jewelry and loose long hair. These can get caught in moving parts or on the controls and could cause serious injury.
- Before using (PPE), - add (PPE) after equipment, be sure it is in good condition and will be able to perform its task.
- If required, wear a safety helmet, safety glasses, safety shoes, face mask and

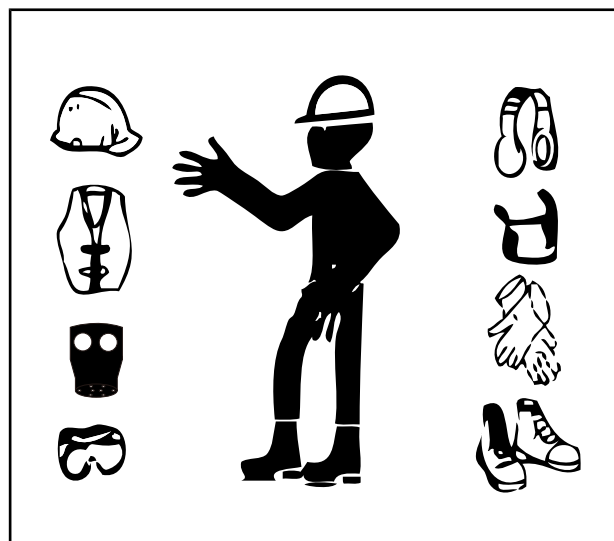

Fig 2-37

gloves when operating or maintaining the machine.

- Wear hearing protection when working near loud noises.
- Personal protective equipment must, as a minimum, comply with the requirements of the specified standards
- Safety helmet

A safety helmet protects your head against, for instance, falling concrete or parts of the delivery line in the event of a hose bursting.

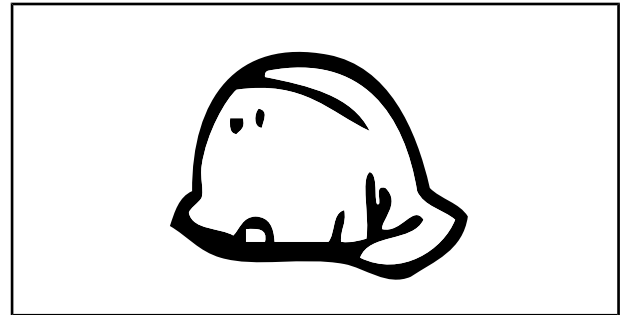

Fig 2-38

- Protective clothes

Protective clothes protect you from being caught by moving parts.

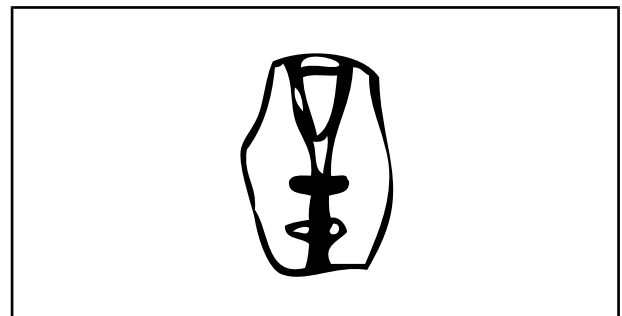

Fig 2-39

- Face mask and respiratory protection

A face mask and respiratory protection protect you against particles of building materials which could enter your body through your respiratory passages (e.g. concrete admixtures).



Fig 2-40

- Protective goggles

Protective goggles protect your eyes against injuries from concrete spatters or other particles.

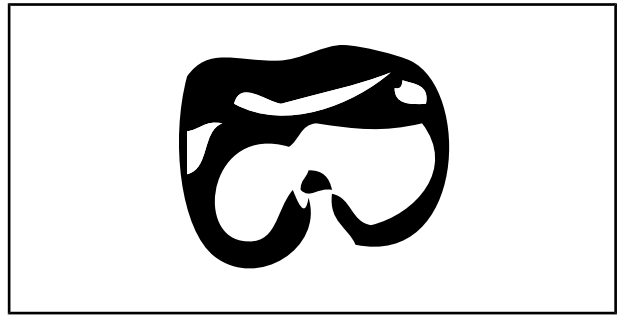

Fig 2-41

- Hearing protectors

Hearing protectors protect you against the noise generated by the machine when you are standing close to it.

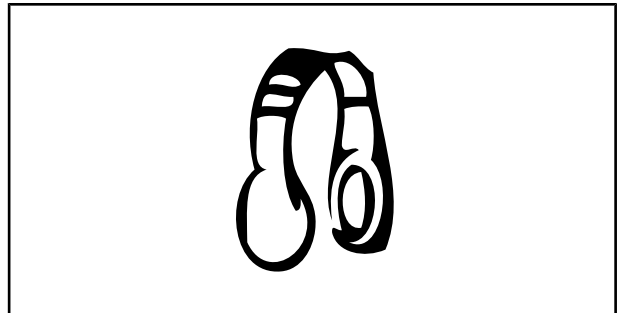

Fig 2-42

- Protective mask

Protective mask protect you from particulate pollutants.

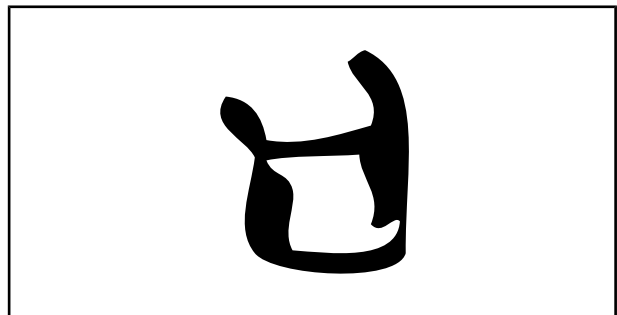

Fig 2-43

- Protective gloves

Protective gloves protect your hands against aggressive or chemical substances, as well as against mechanical effects (e. g. impact) and cutting injuries.

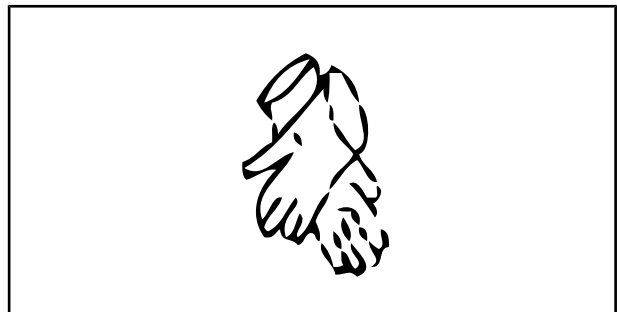

Fig 2-44

- Safety footwear

Safety footwear protects your feet against falling objects and against penetration by projecting nails.

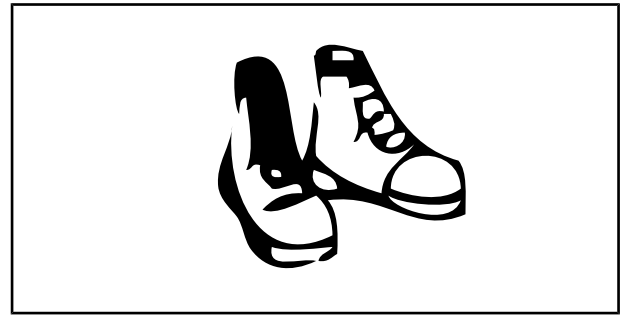

Fig 2-45

2.3.6 Precautions against Emergency

Fully read the operation regulations and local driving laws, mastering the meaning of signal, gesture, symbol, and notification. Before driving the roller, it is forbidden to take excitant drink or drugs.

Find out the places placing fire extinguisher, emergency apparatus, and alarm telephone as well.

Avoid commonsense accidents. If accident occurs, try to adopt effective measures rapidly. First of all, it is most important to guarantee the personal safety, and then, consider reducing losses of goods and materials.

Use the emergency stop switch correctly

NOTICE

Risk of machine damage!

The frequent use of the emergency stop switch could shorten the service life of the engine and other important parts.

Except for emergency, do not use emergency stop switch.

When an emergency incident happens, the operator can press down the emergency stop switch immediately to stop the roller. The switch is installed on the side box.

When the incident is eliminated, the operator can release the switch by rotating it clockwise and start the roller again.

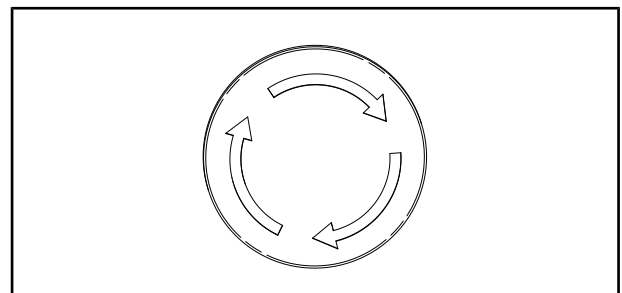

Fig 2-46

Evacuation in fire accident

Evacuate the equipment with the following methods in case of fire accident:

If time is sufficient.

- 1) Move the propel control lever to STOP position.

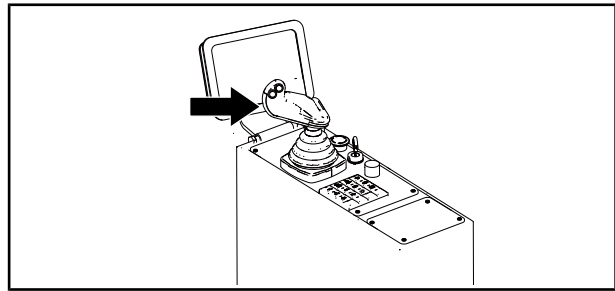

Fig 2-47

- 2) Press the park brake switch on the switch panel.

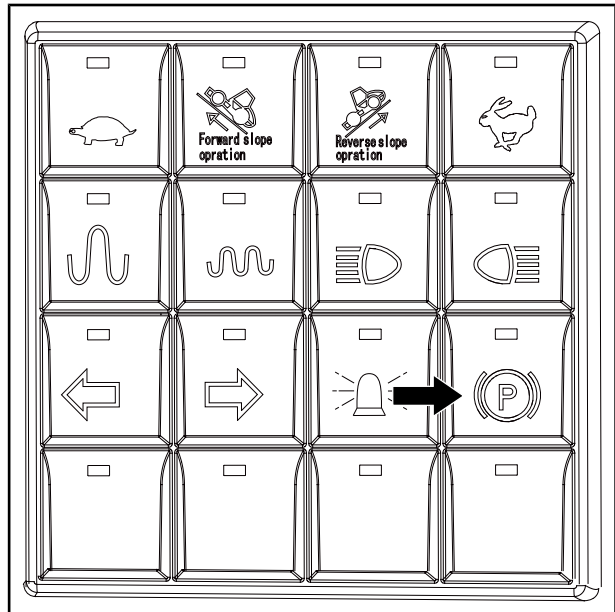

Fig 2-48

- 3) Turn the key switch to the OFF position. Remove the key.

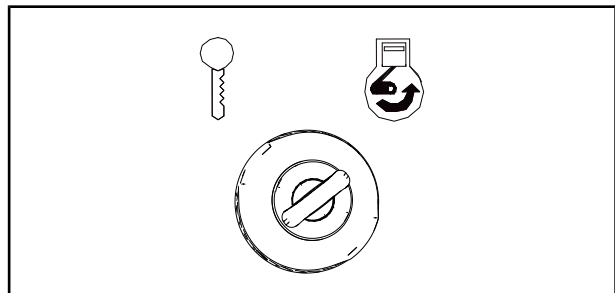

Fig 2-49

4) Evacuate from the equipment.



Fig 2-50

5) Use the fire extinguisher



Fig 2-51

If time is insufficient, press down the emergency stop switch and evacuate from the roller. Then use the fire extinguishers or call fire fighters for help.

Touching high-voltage lines

When working near high-voltage lines, the operator should take extreme care. If the roller touches them during traveling, take measures as follows.

- Never leave the operator's seat.
- Warn other persons to stay away from the roller.
- If possible, drive the roller away from the dangerous area.
- Cut off the power supply of the roller.

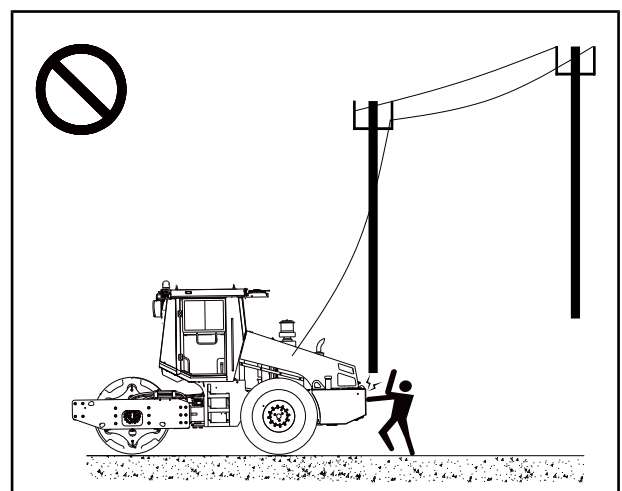

Fig 2-52

Falling object protection

If at a work site, the cabin has the danger of being hit or invaded by falling objects and scattered materials. So the operator must use the protective cover to protect himself according to the operating condition.

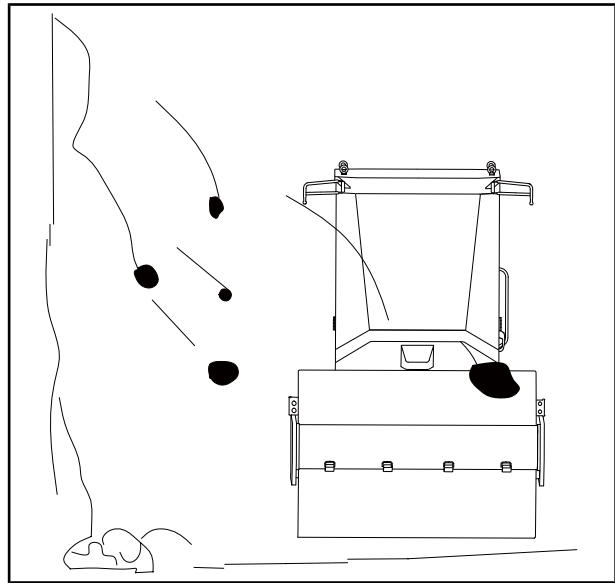

Fig 2-53

2.4 Precautions During Operation

2.4.1 Safe Starting

1. Safe mounting

When you mount or dismount the equipment:

- Always face the roller and maintain a three-point contact (one hand and two feet or two hands and one foot).
- Never jump on/off the roller. Never mount a moving roller.
- Never use any control lever as a handrail.
- Remove the mud, oil dirt and water from pedal, handrails and shoes at any time.

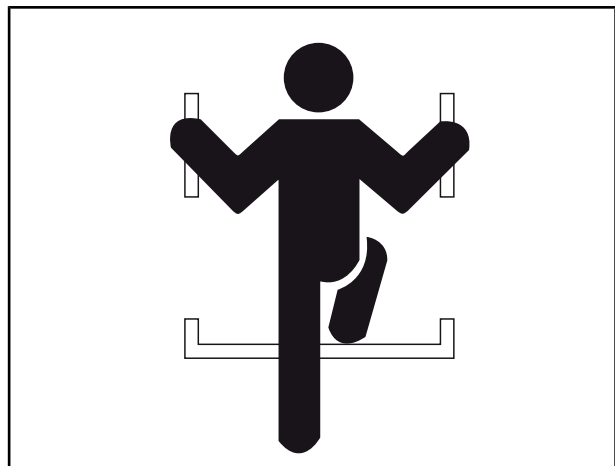

Fig 2-54

2. Seat adjusting

Uncomfortable seat position can easily lead to operator fatigue and operating mistake.

The seat position should be adjusted upon change of operator.

Leaning against the back of seat, operator shall be able to operate the control lever properly. Otherwise, the seat should be readjusted by moving it forward or backward.



Fig 2-55

3. Seat belt

- In case of tipping-over of the equipment, the operator could be injured or thrown out of the cabin, or be crushed by roller, causing serious injury or death.
- Before operating the roller, check the buckles for seat belt and fastening fittings carefully.
- In case of any damage or wear, the seat belt and other attachments should be replaced prior to operation.
- When the equipment is running, be seated in operator seat and fasten your seat belt to avoid accidents.
- The seat belt should be replaced every three years regardless of its condition.

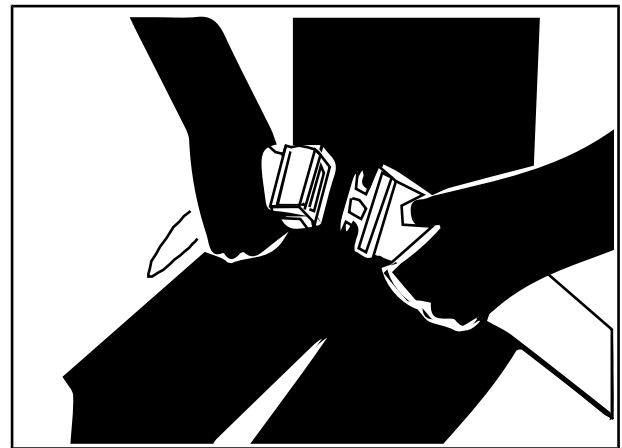

Fig 2-56

4. Before starting the engine

Before starting your daily work, the following items are to be observed prior to start of the engine.

- Check the levels of engine oil, hydraulic oil, windshield wiper tank, and engine coolant.
- Check if the lubrication points are lubricated properly.
- Check air filter for blocking.
- Check wires for damage.
- Set all control switches and levers to "0" position or "NEUTRAL" position except the emergency stop switch.
- Adjust the seat to a position easy for operation; check seat belts and buckles for damage and wear.

- Adjust the rearview mirrors so as to see clearly from the driver's seat what is happening behind the roller.
- Clean the windows to ensure a good vision.
- Clean the headlights and work lights, and check them for regular functions.

5. Engine starting

Before starting, be sure there is nobody under or around the roller. Sound the horn for warning.

- Start or operate the roller in a seated position.
- No one is permitted to stay on the roller except the operator.
- Never start the engine if you think there could be a short circuit, which is dangerous and can cause damage to the roller.

To understand proper starting steps of the roller, see [“Normal Start” on page 4-15](#).

In a cold weather, sufficient warm-up operation is necessary. Incomplete warm-up may result in slow reaction and accidents.

Before starting, check the battery to see if its electrolyte is frozen or leaks. In case of frozen electrolyte, never charge the battery.

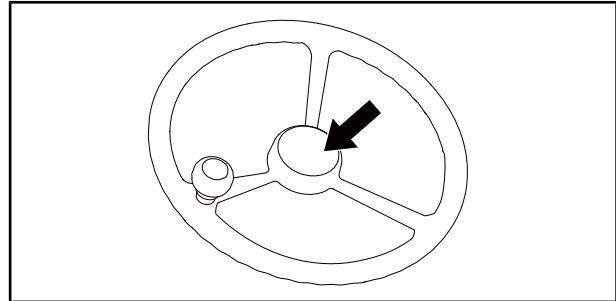

Fig 2-57

⚠ WARNING

Risk of personal injury!
 Improper operation could lead to battery explosion or roller out of control, and could lead to serious accident.
 Never use the jump-start personally. Contact SANY dealer when necessary.

The use of jump-start must be carried out according to the instructions in operation section. See [“Jump-Start” on page 4-16](#). Improper operation can lead to battery explosion or roller out of control, hence personal injury and death.

6. After starting the engine

! WARNING

Risk of death or serious injury!

Roller out of control could cause death or serious injury.

Prior to operation, make sure you could properly control the speed, direction, braking.

Observe the pressure gauges, instrument and warning lights to ensure they are properly functioning, with all readings within specific ranges.

2.4.2 Safe Operation

1. Surveying the work site in advance

! WARNING

Risk of death or serious injury!

The machine could roll over when working at the ditch edge or on road shoulder, which could cause serious injury or even death.

- Do not use the machine on the ground not solid enough or with holes, nor use the machine along the channel or incline road.
- Check the work site and road conditions in advance to prevent the machine from overturning, or even the ground, material stockpile or bank from collapse.

Check the work site and road conditions in advance to prevent the roller from overturning, or even the ground, material stockpile or bank from collapse. Reinforce the ground, ditch edge and road shoulder according to requirements and keep a certain distance between the roller and the ditch edge or road shoulder. Formulate a working plan and use the roller applicable to the work and construction site.

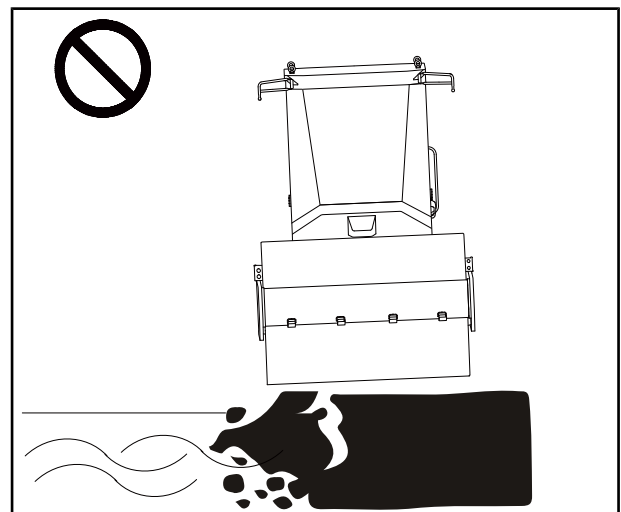

Fig 2-58

For the multi-roller operation, the united signals are required to be applied. Appoint a signalman to organize the operation, and make sure all workers obey the guide of the signalman. A signalman is also on demand when working on a slope or on a road shoulder.



Fig 2-59

Keep especially alert when working on an icy road, since the rise of the ambient temperature will make the foundation soft and slippery.

NOTICE

Risk of machine damage!
Running the machine beyond its allowable gradeability could affect the service of the engine.
Never run the roller on a slope or a muddy road, run the machine within its allowable gradeability.

See [“Specifications of the Equipment”](#) on [page 7-4](#) for the roller's grade ability.

Don't operate the roller on the ground not solid enough or with holes.

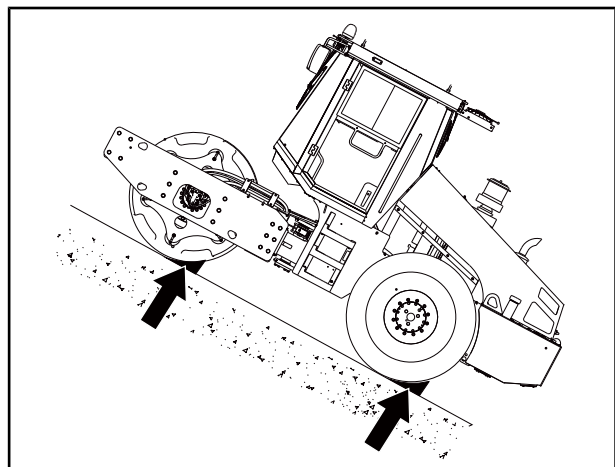

Fig 2-60

Never start up and operate the roller in a combustible and explosive environment. For example, avoid operating it in a narrow or unventilated space. Keep good ventilation in any conditions.

Make sure when the vibratory roller is working, there isn't any vulnerable building and equipment around. The damage caused by the vibratory roller can affect certain distance range.

If the rolling materials will induce dust, install ventilation devices, water the pavement or wear a gauze mask.

2. Before operation

Test the roller before operation.

- When conducting inspection, move the equipment to a spacious area without barriers and operate slowly. No other person is allowed to approach the equipment.
- Check the roller for abnormality such as abnormal noise, vibration, smoke, odor or gauge reading and leakage.
- When the propel control lever is at the "STOP" position, rotate the throttle switch to test the engine's speed and then operate the switch to check if the machine works normally.
- Fully understand the working mode of the roller.
- In case of any abnormality, stop operation and take corrective measures immediately.



Fig 2-61

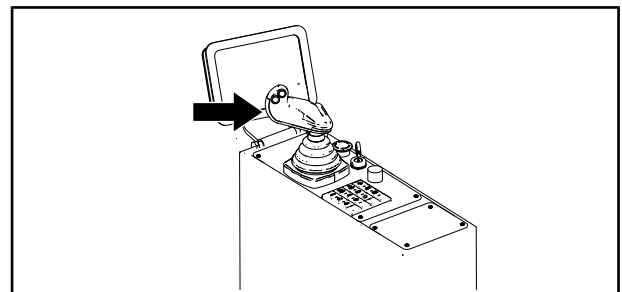

Fig 2-62

NOTE :

When hearing abnormal noise, first check the noise to see if it comes from inside. If it really comes from inside, shut down the roller immediately, otherwise it may lead to further fault.

3. Safe traveling

When driving the roller, the operator should observe the following provisions:

- It's forbidden to carry people on the roller except the operator.
- It's forbidden to mount or jump off a moving roller.

- Operate the equipment only on the operator's seat. Keep the seat belt fastened and the cabin door closed during working.
- Do not adjust operator's seat when driving.
- Sound the horn to warn persons around, and make sure there's no person or obstacle nearby.

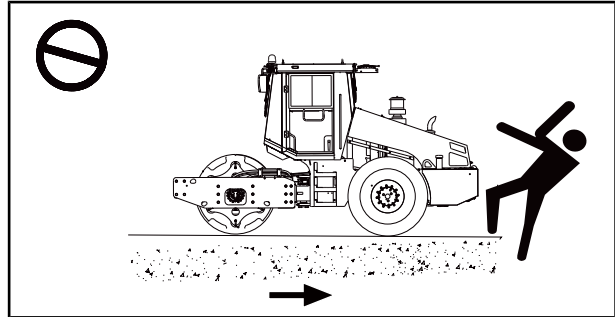

Fig 2-63

- The driving speed should match the working condition. When the road is flat and straight, high speed is allowed; when the road is getting worse, the low speed is demanded.
- Do not operate the machine continuously for more than one hour at high speed (rabbit gear), otherwise the machine can only work at low speed (tortoise gear) or stop at least 20 minutes.
- Only when the roller is stopped can the operator change the gear.
- When traveling on a slope, make sure the degree of the slope is not beyond the roller's allowable gradeability. See ["Specifications of the Equipment" on page 7-4.](#)

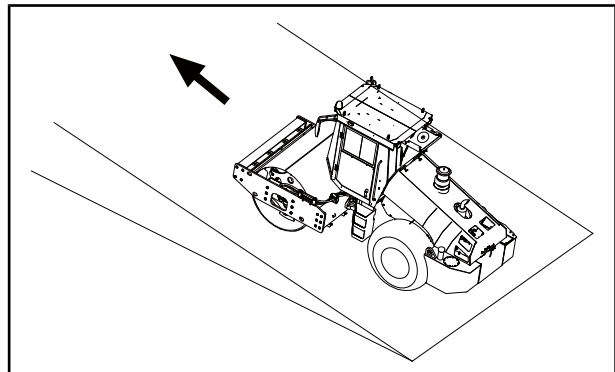

Fig 2-64

- When driving on a slope, it's only allowed to drive upward or downward in a straight line at a low speed. Traveling across a slope is prohibited.
- Do not run the machine on a slope at high speed (rabbit gear). On a slope, the control lever should be operated slowly to drive the machine.

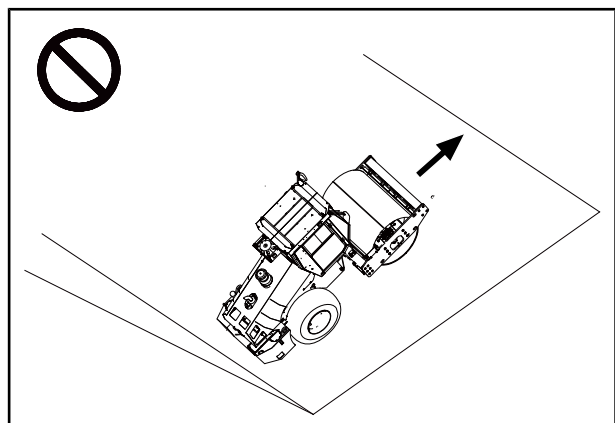

Fig 2-65

- When danger occurs, press down the emergency stop switch immediately. Do not use the emergency stop switch as the normal brake.
- Restart the equipment only after the danger is eliminated.

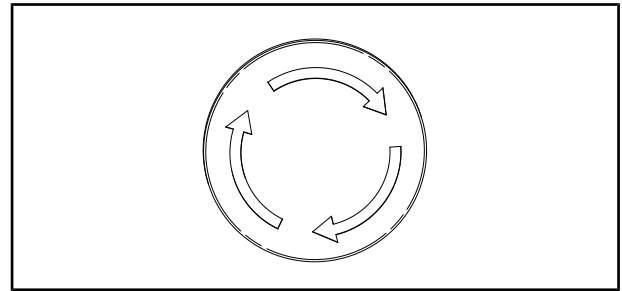

Fig 2-66

- Do not apply P (Parking) knob before the machine stops completely.
- In poor visibility conditions, turn on the work lights for clearer vision.

4. Safe turning

When making turning, the operator should observe the following provisions:

- When changing direction, make sure there is no person near the center articulation frame.
- Only when the roller is at the low speed can the operator change the direction.
- Don't make any abrupt turning.

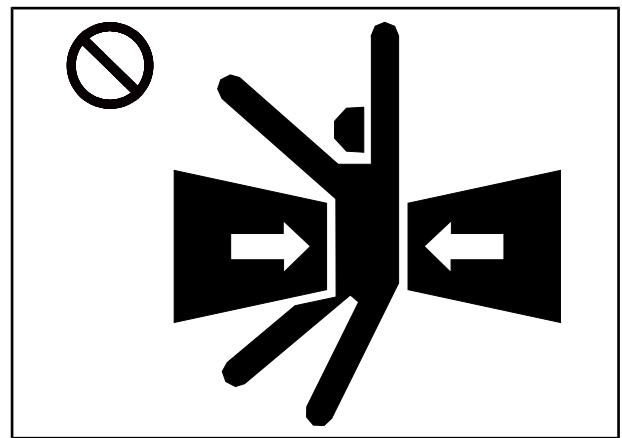

Fig 2-67

5. Safe vibrating

When the roller starts vibrating, the operator should observe the following provisions:

- Never start vibration without travelling; never vibrate when travelling at high speed (gear II).
- Never start vibration on hard ground.
- Take the nearby buildings and underground facilities into consideration before switching on the vibration.
- Don't start vibration on sloppy road, because it will increase the danger of side sliding.

- When compacting the road edges adjacent to pavement, ensure that more than 2/3 of drum width is on the road compacted previously.

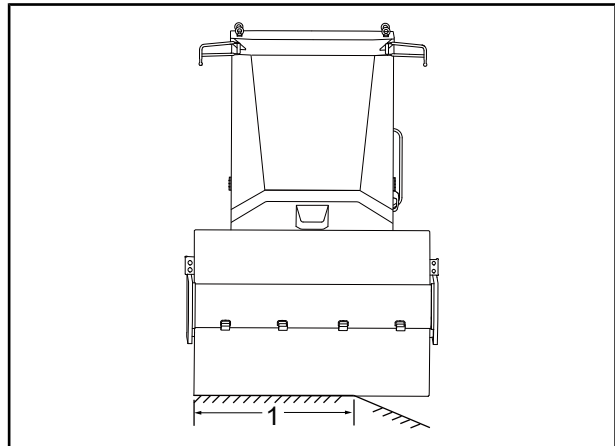

Fig 2-68

1. 2/3 of drum width

- Only when the roller stops vibrating can the operator change vibration frequency or working mode.

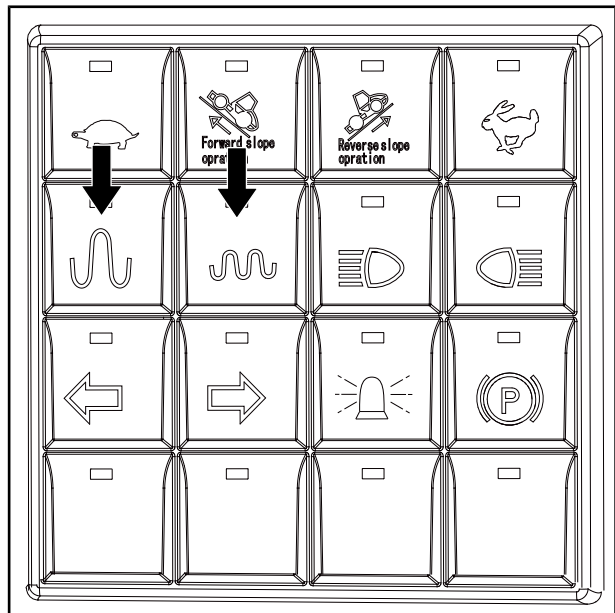

Fig 2-69

2.4.3 Safe Parking

Requirements for parking area

When parking the roller, the operator should observe the following provisions:

- Try to park the roller on flat and solid ground.
- Try to park the roller indoors, avoiding direct sunlight and precipitation.
- If it is required to park on a slope, make sure that the gradient of the slope is not beyond the roller's grade ability. **See** [“Specifications of the Equipment” on page 7-4](#) for more details.
- If parking the road roller in the open air in rain or snow, please protect the control console and the instrument panel in the cab with waterproof covers.

Parking rules

- Follow the parking steps to park the roller. **See** [“Park Brake” on page 4-21](#).
- Do not park the machine on a slope. If unavoidable, operate the control lever until the machine stops completely, and then apply P knob for parking brake, and take measures to prevent sliding. The gradient of slope should be within the allowed scope.

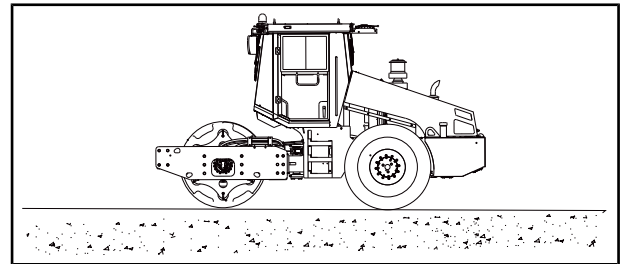

Fig 2-70

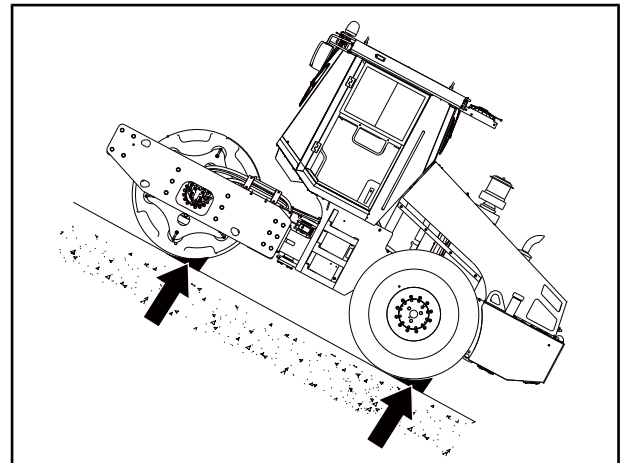

Fig 2-71

2.5 Maintenance Precautions

2.5.1 Basic Rules

- It is forbidden to use a damaged roller or the one with potential troubles.
- Only the qualified and authorized maintenance staff can maintain the equipment.
- Observe the maintenance regulations, including spare parts replacement.

2.5.2 Lockout/Tagout Procedures

Only authorized employees performing repairs on the roller shall perform lockout/tagout in accordance with the procedure listed below.

If the employee performing repairs to the roller is issued a lock and key, the employee shall not share the lock or key with other employees until all repair procedures are complete and the machine is ready to put back into service.

The following steps shall be performed in the sequence listed when the roller is to be locked out and tagged-out for service or repair.

Locking out of service

- Notify all employees who may be potentially affected by the repair or maintenance on the roller.
- Secure the machine in a safe position. Press the parking brake switch.
- Identify, remove or disconnect all power or energy sources and be sure to install a lockout/tagout device on them.
- Be sure all employees involved in the repairs have installed the lock on the power source before performing any repairs. Once an employee has completed the repair procedure, they must remove the lock and not access the roller in any manner.



Fig 2-72

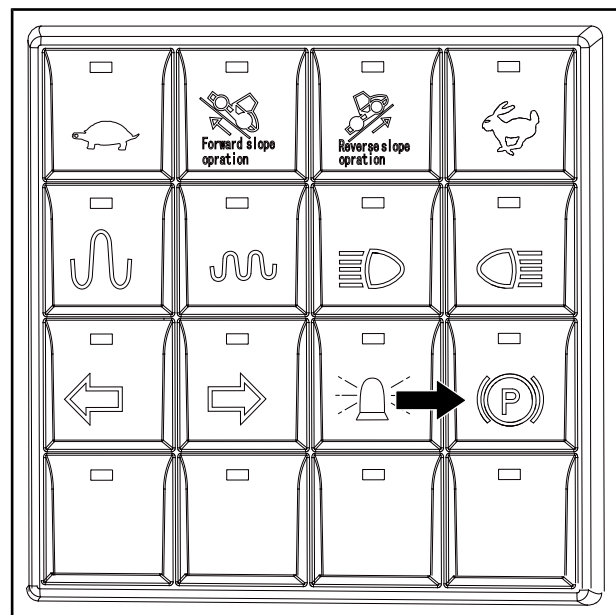

Fig 2-73

Returning to service

- The authorized person who performed the lockout/tagout procedure shall check the area around the roller to ensure that no one is exposed to any hazard before start-up.

- The authorized person who performed the lockout/tagout shall ensure that all guards have been reinstalled to their proper place, all tools and equipment have been removed and all locks are removed.
- The authorized person who performed the lockout/tagout shall verify that all controls are at the neutral or O position and all personnel are aware of the time the roller will be back in service.
- Remove the lockout/tagout mechanisms and all tags and re-energize the roller for return to service.

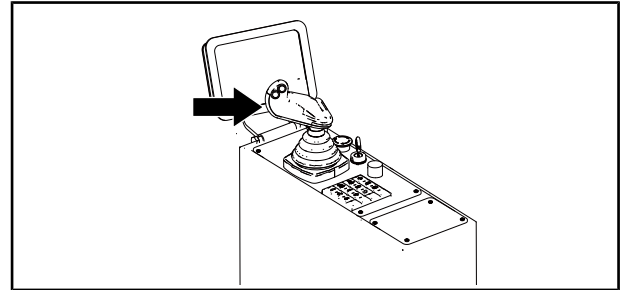

Fig 2-74

2.5.3 Working Area Preparation

⚠ CAUTION
<p>Risk of personal injury! If a clean and tidy working area cannot be guaranteed, there could be risk of tipping, thus resulting in personal injury.</p> <ul style="list-style-type: none"> • For maintenance work, select a spacious, clean and flat area with ample sunlight and good ventilation. • Clean the working area by removing fuel, lubricant and water. Cover slippery ground with sand or other absorptive materials.

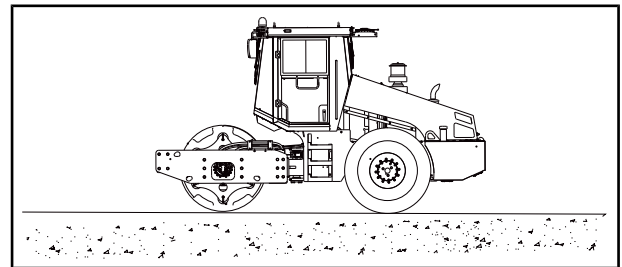

Fig 2-75

2.5.4 Washing the Equipment

When washing the equipment, always do as follows:

- Wear non-slip shoes to prevent yourself from slipping on the wet surface.
- When using high-pressure steam to wash the equipment, always wear protective clothing. This will protect you from being hit by high-pressure water, and cutting your skin or getting mud or dust into your eyes.
- Prohibit the use of high-pressure water to flush the engine assembly.
- Never spray water directly onto the electrical system (sensors, connectors). If water

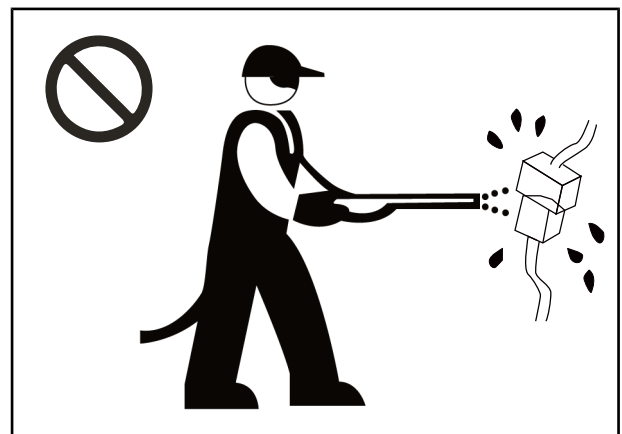

Fig 2-76

gets into the electrical system, there is danger that it will cause defective operation and malfunction.

2.5.5 Self-Preparation

Only approved personnel can maintain or repair the equipment. An observer could be assigned if necessary.

Wear protective clothing and shoes necessary for the job.

- Wear rubber apron and rubber gloves when handling corrosive materials. Wear heavy gloves when handling wooden materials, wire ropes or sharp-edged metals.
- Wear a face shield when removing spring or elastic parts, or adding acid to battery.
- Wear safety hat and goggles when you weld or cut with a torch.
- Never carry out grinding, flame cutting or welding without aspirator and ventilation equipment.



Fig 2-77

2.5.6 Proper Tool

Use proper tools and use them correctly. Using damaged, inferior, defective, temporary tools or using the tools incorrectly could lead to serious accidents.

Be careful when using the following kinds of tool.

- When using a spanner to disassemble bolts and nuts, please refer to the torque table (see ["Torque Values" on page 5-5](#)).
- When using instruments, please follow their instructions.
- When using gas cutting or gas welding equipment, make sure that the work won't lead to explosion or cause the precise parts to lose precision.

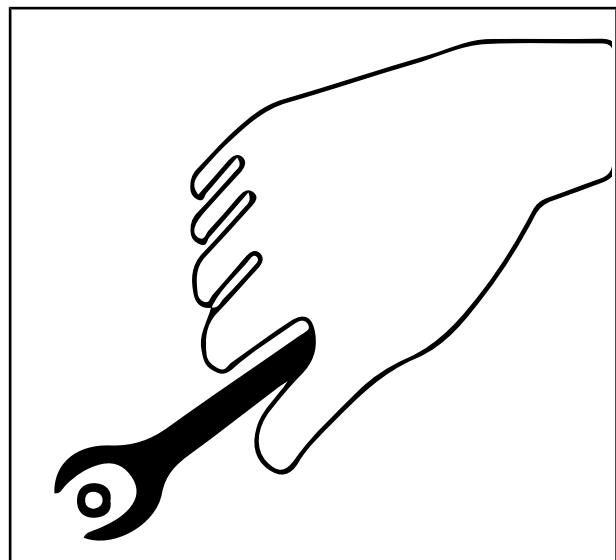

Fig 2-78

- When using grinding wheel to burnish parts, it is not permitted to stay at the tangent direction of the grinding wheel.

2.5.7 Maintenance with Engine Running

In most cases, the engine should be shut down prior to the maintenance work. If maintenance has to be done on a running engine, there should be at least two people handling the maintenance according the following rules.

- One person should always be seated in operator's seat and ready to shut down the engine at any time. All personnel must keep in touch.
- Place the travel control lever to "STOP" position in order to prevent movement of work equipment. If it must be used, send signal to others and warn them to move quickly to a safe area.

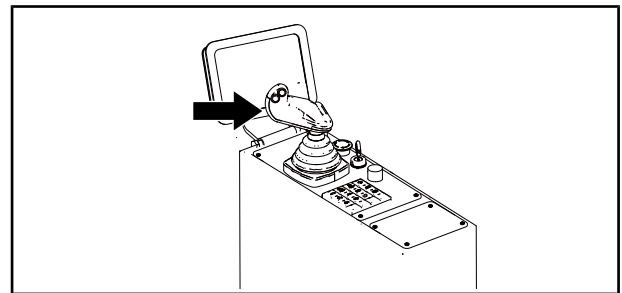

Fig 2-79

- Pay special attention to rotating parts like fan and conveyor belt, people may get caught by them when staying close.
- Never leave or insert any tool or other objects in fan or conveyor belt, which may cause the parts to break or fly.

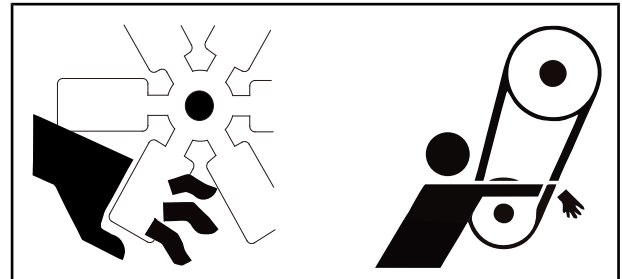

Fig 2-80

2.5.8 Working under the Roller

- No maintenance shall be carried out before the roller is well supported. Make sure that the roller and its accessories are safely, stably and reliably supported.
- Never use bricks or wood blocks to support the roller.
- Never use the device which may slide to support the roller.
- Never use slag bricks, hollow tires or shelves to support the roller, as they may collapse under continuous load.
- If the roller or the accessories must be raised up for maintenance, the roller or its working device shall be supported with multiple jacks or iron columns.



Fig 2-81

2.5.9 Working in Noisy Environment

Loud noise from the roller could do harm to the hearing.

When maintaining the engine, wear ear covers or ear plugs if you have to work in noise for a long time.



Fig 2-82

2.5.10 Removing Paint before Welding or Heating

- Poisonous gas will be produced by paint heating during the fusion welding, soldering or gas torch application.
- Remove the paint outdoors or in the places with good ventilation.
- If using sand paper or grinding wheels to remove the paint, wear a qualified respirator to protect yourself from inhaling dust.
- If the solvent or the rust remover is used, the paint and solvent shall be handled in a proper way. Wait for at least 15 minutes for volatilization of volatile gas before welding or heating.

2.5.11 Correct Welding

WARNING

Risk of personal injury!

Welding near the leaked oil tank or oil tube could lead to fire and endanger the worker's safety.

Do not weld near the leaked oil tank or oil tube.

CAUTION

Risk of personal injury!

Welding near the plastic and rubber materials could produce toxic fume and could do harm to the worker's health.

Welding near the plastic and rubber materials is forbidden, such as, near the scraper made by polyurethane.

The correct welding procedures must be used to protect the electronic control and the bearings from being damaged. When carrying out welding on the roller equipped with the electronic control, comply with the following procedures:

1. Stop the engine, and remove the key after turning the key switch to the left end.

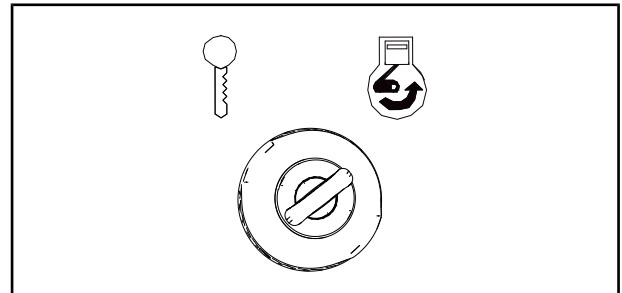

Fig 2-83

2. Remove the negative cable of the battery. Never use the grounding point of electric spare part (including electric control modules or sensors) as the grounding point of the electric welder.
3. Clip the components to be welded with the grounding wire clamp of the welder. Set the clamp near the welding point to make sure the current flow is away from the key components, such as transmission system bearing, hydraulic parts, electrical parts, and so on.
4. Protect the wire harness from contacting scraps and splashes produced during the welding.
5. Weld the materials together by following standard welding process.

2.5.12 No Heating beside Hydraulic Pipeline

- Heating beside the pressure pipe will produce combustible spray, which may cause the operator and the bystanders to be seriously burned.
- Fusion welding, soldering or usage of gas torch beside hydraulic pipeline or other combustible materials are not permitted.
- When the heat goes beyond the direct combustion area, the hydraulic pipeline may be cut off at any time. Establish a temporary fire protective sleeve when performing fusion welding or soldering to protect hoses or other material.

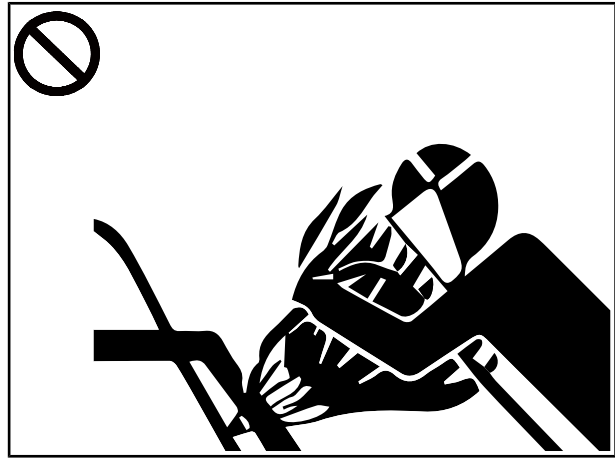

Fig 2-84

2.5.13 No Heating the Pipes with Combustible Liquid

- Welding or gas cutting of the pipeline or hose with combustible liquid is not allowed.
- Remove the combustible liquid completely with noncombustible solvent before welding or gas cutting the pipeline.

2.5.14 Correctly Operating the Hydraulic System

- Periodical maintenance to the hydraulic system is very important. The hydraulic system of the roller works under high oil pressure, small damages and cracks at the rubber hose and the adaptor will cause disastrous results. As the hydraulic tube is made up of rubber, cracks will appear after a certain period; in any circumstances. If the service life of the rubber tube is uncertain, replace it with a new rubber hose provided by SANY.
- Never fill oil directly to the hydraulic oil tank, otherwise the cleanness of the hydraulic system may be influenced, and the valid life of the equipment may be reduced! When filling the hydraulic oil tank, use a filtering equipment with a filtration precision of 10 μm .
- Make sure that the pressure control valve is set correctly. High pressure will result in hydraulic line leakage. Low pressure will result in difficult operation of the roller.
- Adjustment of the system pressure, main oil pump as well as installment, removal or replacement of the valve block only can be done under the instruction of a hydraulic engineer or an after-sales engineer. Unauthorized persons are not permitted to adjust by themselves.
- As the rubber hose is an easily-corrosive product, do not store it for a long time.
- When dismantling the oil pipes, close the port and keep the hydraulic pipeline clean.
- Check the filter element frequently.

- The hydraulic parts are essential to the system. Use the original hydraulic parts produced by our company.

2.5.15 Being Aware of High-Pressure Liquid

- The hydraulic system may still have pressure even the operation is stopped. Liquid like diesel oil and hydraulic oil spurting out under pressure may penetrate the skin or eyes resulting in serious injury, blindness or even death.



Fig 2-85

- Release pressure before disassembling the hydraulic parts or other pipelines to avoid such dangers caused by high-pressure liquid.
- Fasten all joints before pressurizing.
- Wear protective goggles, masks and gloves when checking the hydraulic system. Use cardboard when checking for leaks.

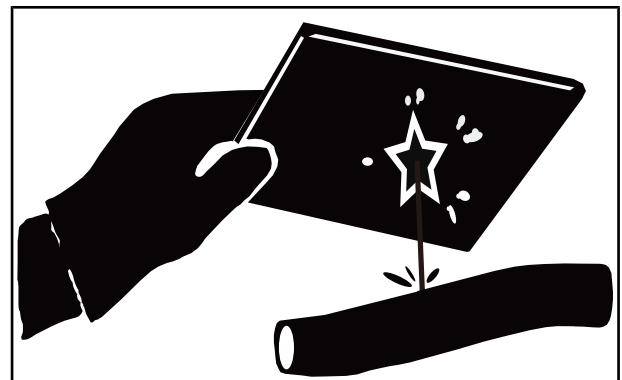

Fig 2-86

- Protect your hands and body from contacting with high-pressure liquid. If the hydraulic liquid splatters onto the skin or into the eyes, seek medical care immediately.
- If any liquid jets into skin, remove it within several hours by surgical treatment from a professional surgeon.

2.5.16 Regularly Replacing the Rubber Hoses

- Rubber hoses with combustible liquid may break under pressure due to aging and excessive abrasion. The ageing and abrasion of the rubber hoses are difficult to be judged only through check. Regularly replace the rubber hose.

2.5.17 Avoiding Scald by High-Temperature Liquid

- After operation, the coolant in the engine becomes hot with pressure, and the water pipes of the engine and the radiator are full of hot water and vapor. Avoid scald by possibly jetting hot water. Hot water or vapor overflowed will result in serious scald.
- Before removing the radiator cover, stop the engine and let the system cool down. The radiator cover could only be removed after the cooling fluid has cooled down.
- The hydraulic oil tank is pressurized after operation. Release the pressure before removing the cover.
- The engine, gear and hydraulic oil will turn hot during operation; meanwhile, the engine, hose, pipeline and other parts will turn hot. Check or maintain the equipment after the oil and parts cool down.

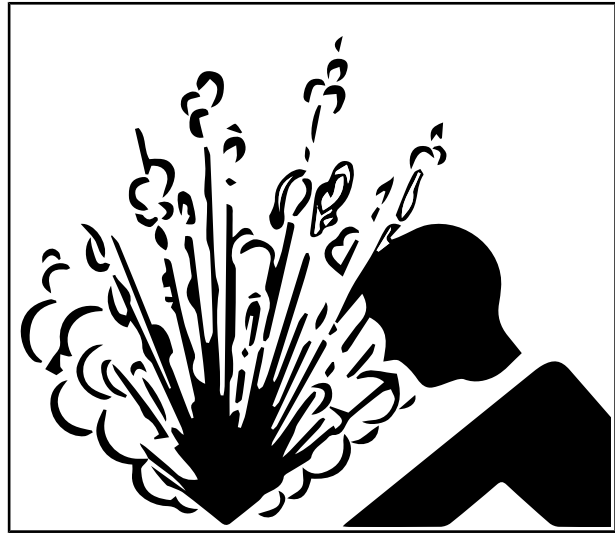

Fig 2-87

2.5.18 Preventing Battery from Explosion

⚠ WARNING

Risk of personal injury!
Charging a frozen battery could lead to explosion, which could result in serious injury. Warm the battery to 16°C at first before charging the frozen battery. Keep the battery away from open fire or sparkle.

- The battery contains toxic and corrosive sulfuric acid. If the battery explodes, the electrolyte may spatter into eyes, which may cause blindness. Always wear goggles before checking the electrolyte.

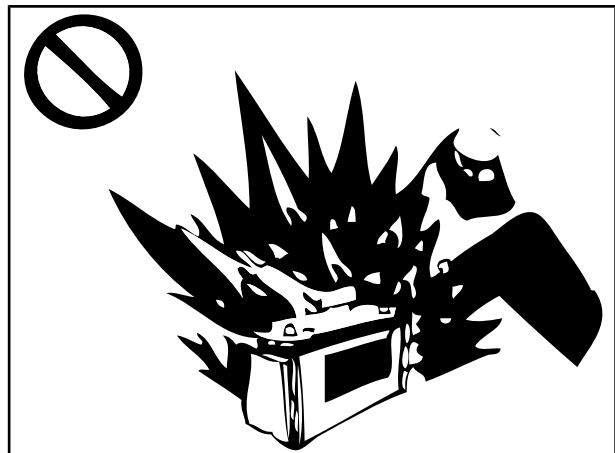

Fig 2-88

- Wear gloves when operating the battery. Battery electrolyte is strongly corrosive. If your clothing and skin are contaminated by electrolyte, flush immediately with large amount of water and then seek medical treatment immediately.
- Don't charge a frozen battery, which may lead to explosion. Warm the battery to 16°C at first.
- The gas produced by the battery is easily explosive; if the battery is very close to open fire or sparkle, explosion will possibly occur.
- Take extreme care when installing and replacing battery so as to avoid short circuit. When removing the connection of the battery, first cut off the negative terminal.
- When charging the battery, first disconnect the power supply of the charger before connecting the charger with the cable of the battery.

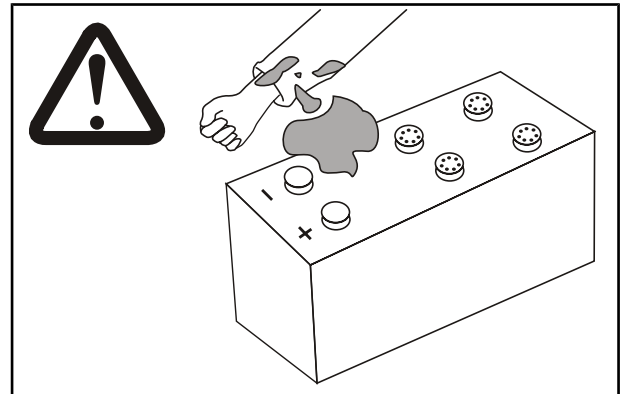

Fig 2-89

2.5.19 Preventing Components from Flying out

Since the components may fly out, keep your body and face away from the valve body to avoid injury.

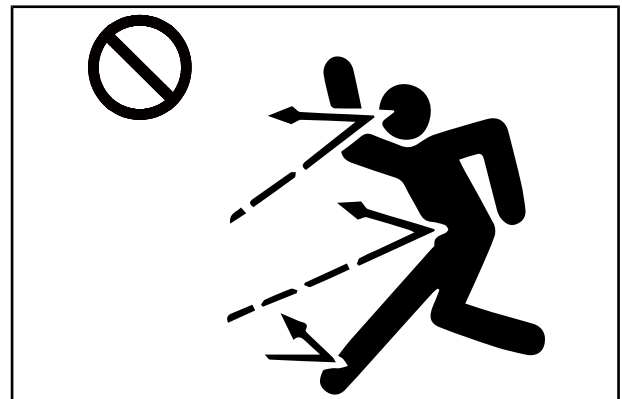

Fig 2-90

2.5.20 Safe Storage of Parts

- The stored parts may fall off, resulting in severe injury or death.
- Store the parts and instruments properly to prevent them from falling. Keep children and other persons away from the storage area.



Fig 2-91

2.5.21 Safe Treatment of Liquid

- No smoking when refilling the fuel tank.
- Stop the engine before refilling.
- Refill outdoors.
- Store the combustible liquid away from the places where fire easily bursts out.
- Don't burn or pierce the pressure container.
- Don't store the oily cloth because it is easily ignited or easily burns spontaneously.



Fig 2-92

2.5.22 Safe Treatment of Chemicals

- Contacting hazardous chemicals directly will cause serious personal injury. The chemicals used for this equipment include lubricant, coolant, paint and adhesive.
- Check and understand the hazardous character of the chemical before using it. Use recommended instrument in accordance with the regulations.

2.5.23 Proper Disposal of Wastes

- The incorrect disposal of wastes will endanger the environment and ecology. The toxic substances hidden in the equipment of SANY involve oil, fuel, coolant, brake fluid, filter and battery and so on.
- Use a leak-proof container to drain fluid and deliver it to an approved environment friendly waste disposal unite. Never use the container used for food or drink.
- Never pour waste fluid on the ground, into the sewer or any water sources.
- Consult the local environmental protection or recycle center or your appointed distributor for correct recycle and disposal methods of wastes.

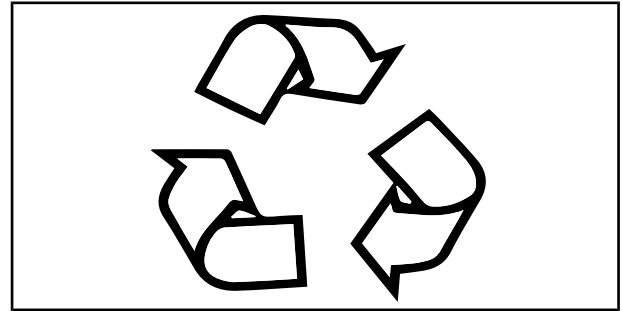

Fig 2-93

2.6 Safe Transportation

2.6.1 Load/Unload the Roller

When loading or unloading the roller from the truck or platform trailer, the roller may overturn.

Provide a truck or platform trailer with suitable size and load to transport the roller.

Precautions during the loading/unloading of the roller.

- Choose the solid and level ground.
- Adopt a platform or incline.
- Assign a signalman to guide the loading/ unloading of the roller.
- Since it is quite dangerous to steer on the incline, avoid steering when driving upward or downward on the incline. If necessary, drive the roller back to the ground and correct the direction before driving on the incline.
- Carefully drive over the convex adaptor between the incline top and the flat plate.
- For more details on how to load and unload the roller, see [“Using a Slope” on page 4-25](#).

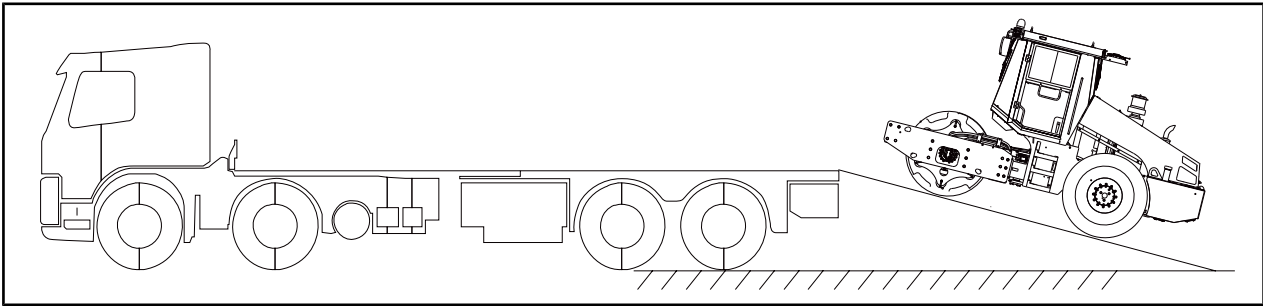

Fig 2-94

2.6.2 Transport the Roller

NOTE :

Articulation lock must be in closed position during the transport.

- Observe the local laws and regulations when transporting the equipment by highway.
- Wedge the wheels with triangle wood blocks and fasten the roller with other measures during the transportation by sea and by road. Besides, reserve some fuel for loading, unloading and transportation, and then disconnect the circuit between the storage battery and the frame.

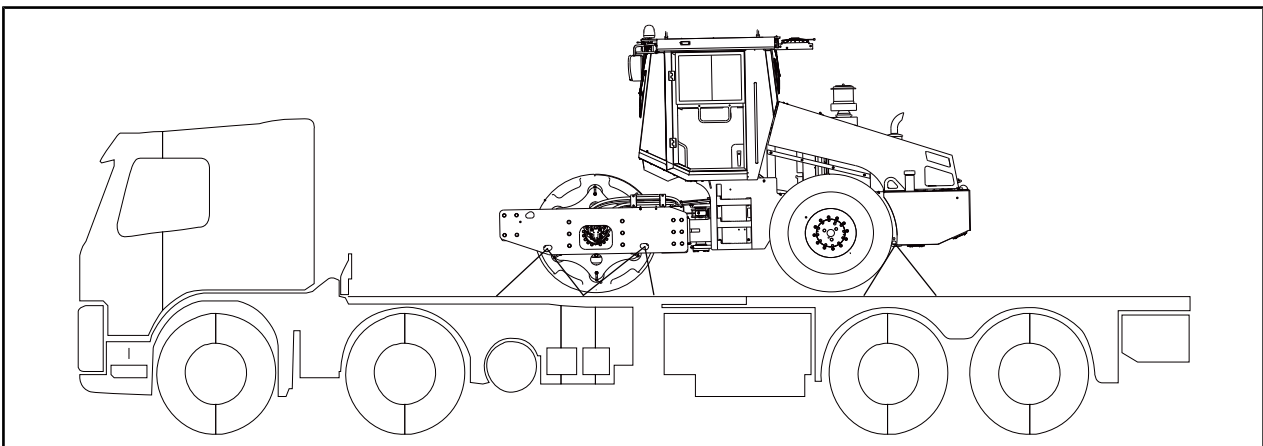

Fig 2-95

2.6.3 Lift the Roller

Small-sized roller can be loaded to the truck by a crane.

⚠ WARNING

Risk of death or serious injury!
Improper lifting could lead machine to fall down, which could cause personal crushing or even death.
Strictly use the correct lifting method.

- In any small-sized roller there are lifting eyes. Use qualified lifting hooks and ropes appropriately.
- Before lifting the roller, lock the center articulation frame by a limit plate (as shown in the right figure) to avoid turning.

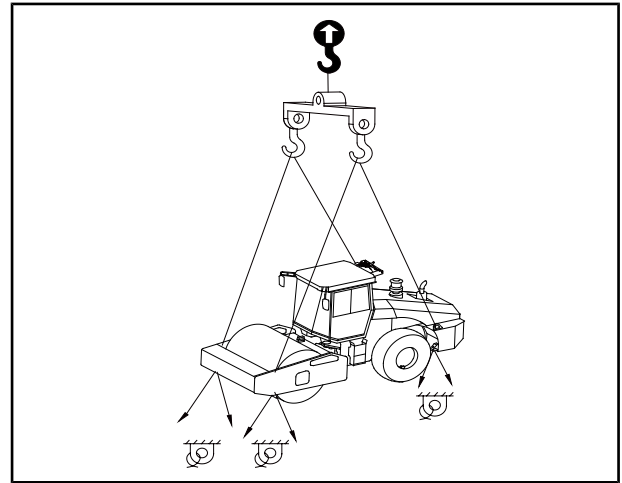

Fig 2-96

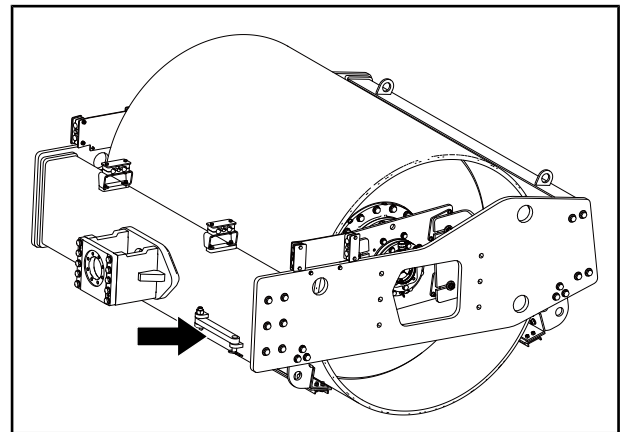

Fig 2-97

- The total weight of the roller is marked on the nameplate. When lifting the roller, check the weight on the nameplate and operate in consistence with the safety regulations of the crane.

SANY

System Function

3 System Function	3-1
3.1 Exterior Components.....	3-3
3.2 Control Console.....	3-3
3.3 Display	3-13
3.4 A/C Panel	3-22
3.5 Radio.....	3-24

3.System Function

3.1 Exterior Components

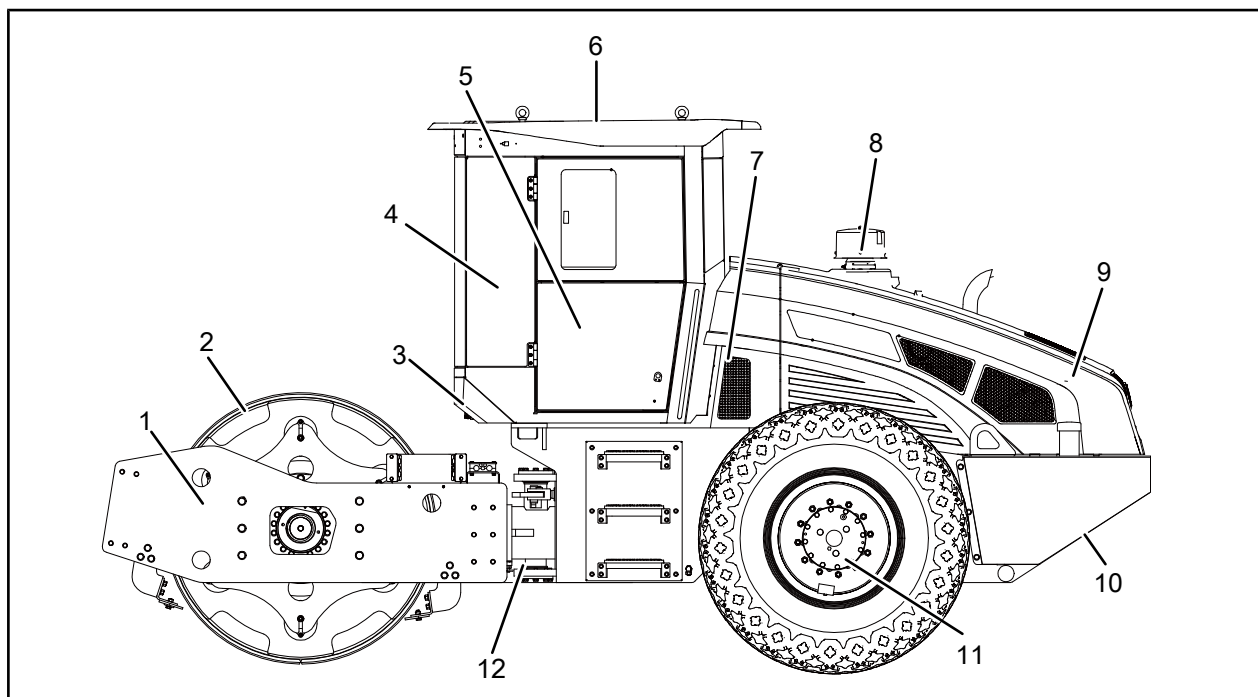

Fig 3-1

- | | | | |
|---|-----------------------------|----------------------------|--------------------------------|
| 1. Front frame | 4. Control system | 7. Air conditioning system | 10. Rear frame |
| 2. Vibratory drum(drum with assembled pad foot is optional) | 5. Electrical system | 8. Power system | 11. Rear axle assembly |
| 3. Hydraulic system | 6. Cab (canopy is optional) | 9. Engine hood | 12. Central articulation frame |

3.2 Control Console

If the actual installations are not in accordance with the figure, the configuration on the machine shall prevail.

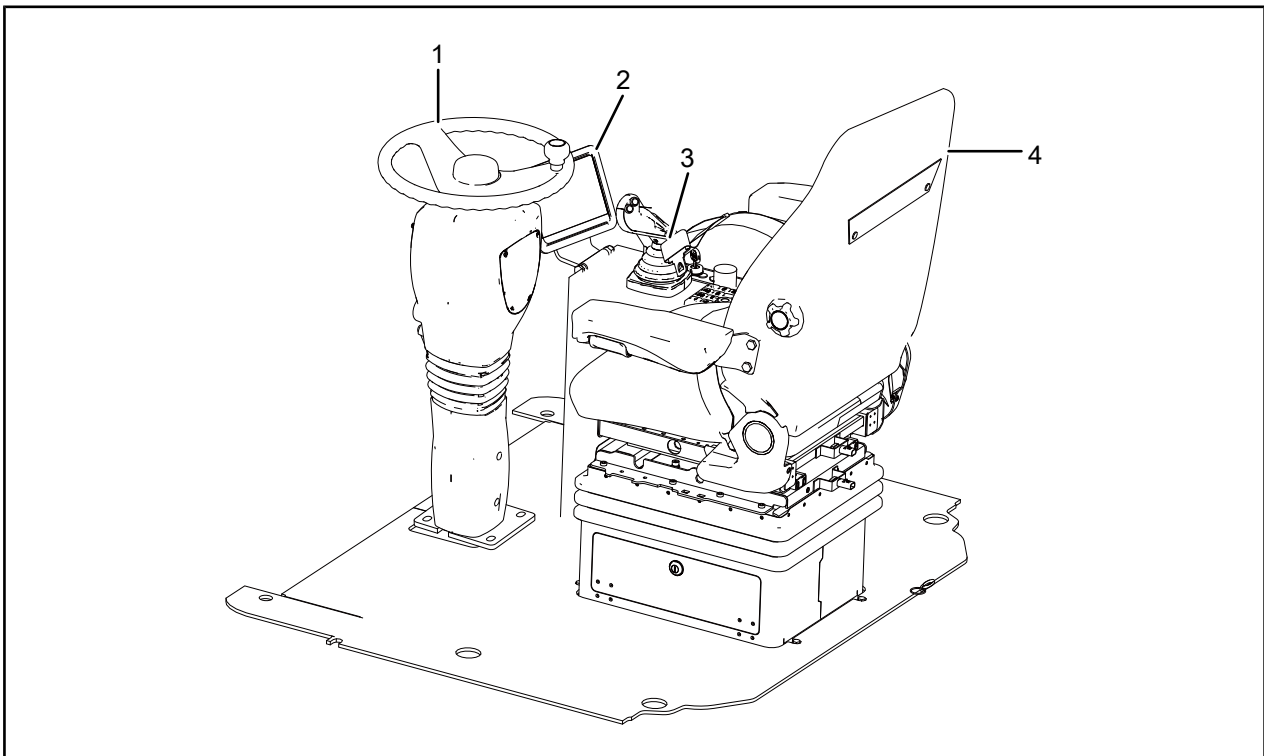

Fig 3-2

1. Steering wheel

2. Display

3. Right control box

4. Seat

- Steering wheel: Rotate the steering wheel to the target direction for the roller steering.
- Adjusting handle: Adjusting the angle of control console according to personal needs by operating the adjusting handle.

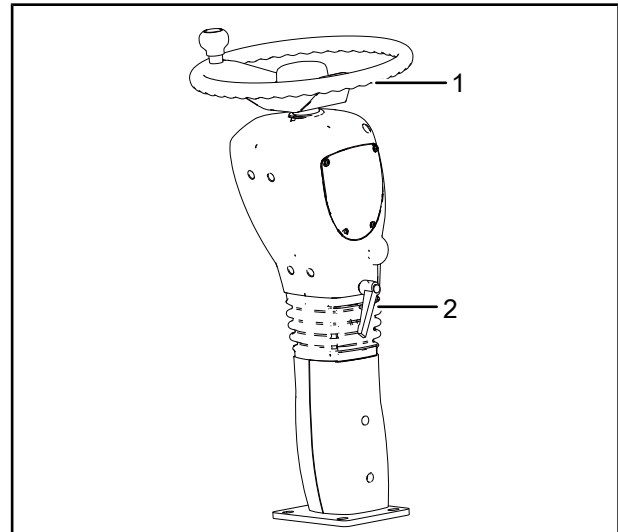

Fig 3-3

1. Steering wheel

2. Adjusting handle

Horn button

Press the horn button, the purpose is to warn the people in the job-site..

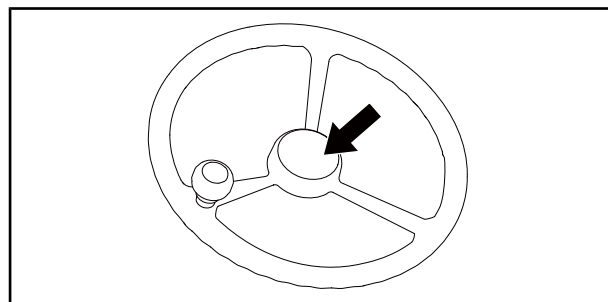

Fig 3-4

Driver's seat

This machine is equipped with a fully adjustable seat. To prevent fatigue, adjust the seat according to the operator's need before operation.

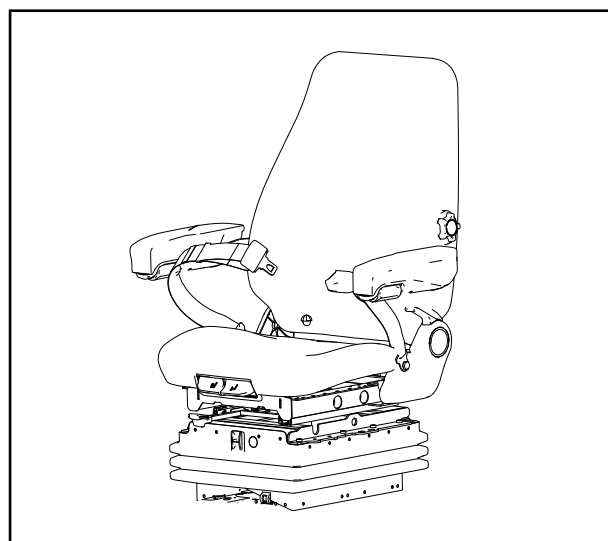

Fig 3-5

Master power switch

The master power switch controls the power supply for the roller. Ensure to connect the master power switch before the engine is started. Disconnect the master power switch after daily work has been finished. The position of the mater power switch is shown in the right figure.

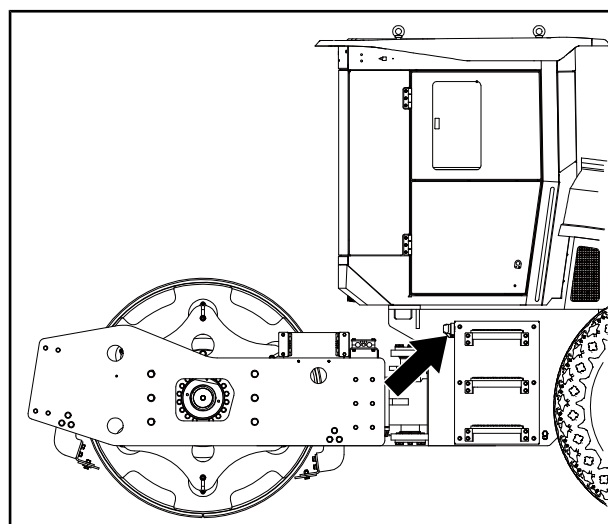

Fig 3-6

Propel control lever

When engine starts, the propel control lever controls the movement of the roller.

- Position STOP: Roller stays stationary.
- Push forward from position STOP: Roller drives forward.
- Pull backward from position STOP: Roller drives reverse.

Distance of the lever from the "STOP" position determines the speed of the roller.

Vibration button

The vibration button is installed on the propel control lever. It controls the startup or shutoff of vibration.

- Press down: Vibration startup.
- Press again: Vibration shutoff.

NOTICE

Risk of machine damage!
Operating the vibration while the machine is stationary could damage the bearings.
Do not operate vibration while the machine is stationary.

Emergency stop switch

NOTICE

Risk of machine damage!
The frequent use of the emergency stop switch could shorten the service life of the engine and other important parts.
Except for emergency, do not use emergency stop switch.

- Press the switch down to shut down the engine.
- Rotate the switch clockwise to release the emergency stop.

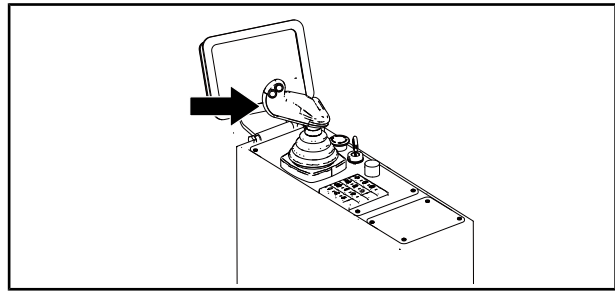

Fig 3-7

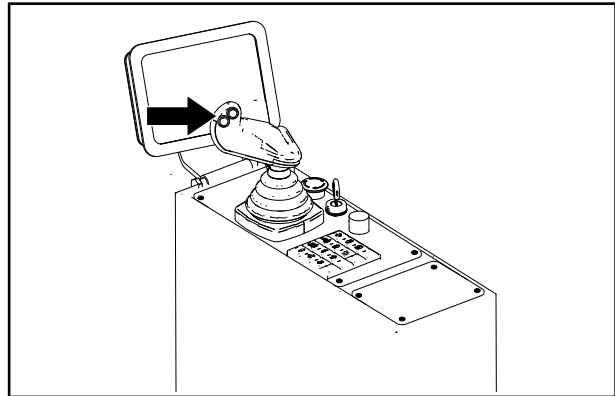

Fig 3-8

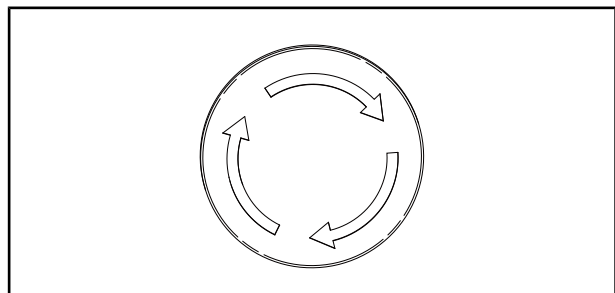

Fig 3-9

If the roller needs to be restarted, first switch the propel control lever to the neutral position and then power on the engine. Push the lever to make the roller run.

Ignition key switch

The ignition key switch is used to power on or off the engine.

- Position OFF: Stop position. It allows you to insert or remove the key. The electrical system is off and the engine is shut down.
- Position ON: Working position. The control system and circuits are energized. Keep the ignition key switch in the "ON" position when operating the engine.
- Position ST: Ignition position. Activates the starter, and keep the key in the "ST" position. Until engine starts, release the key immediately after it is started. The key will return to the "ON" position automatically.

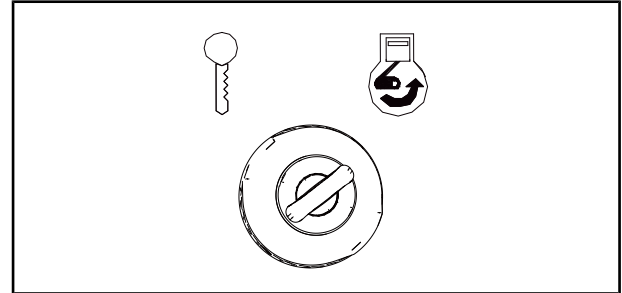

Fig 3-10

NOTICE

Risk of the engine damage!
It could shorten the service life of engine if the engine stops at high speed.
Except for emergency, do not shut off the engine while it is running at high speed.

NOTICE

Risk of the engine damage!
It could shorten the service life of engine if each starting time exceed 10 seconds and the interval less than 5 minutes.
Stop starting and find out the cause If it cannot be started after 3 attempts continuously.

Throttle control switch

Turn the throttle control switch to adjust the throttle. When starting and stopping the engine, the throttle control switch should be at the "MIN" position to make the engine idle for 3-5 minutes.

NOTE :

If the roller has not been in use for a long time, the warm up time of the engine should be properly increased. During winter, the idle warm up time should be prolonged to 8 min - 10 min.

Gear selection switch

There are four speed gears: Gear I: 0–3.5 km/h; Gear II: 0–6 km/h; Gear III: 0–7 km/h; Gear IV: 0–11 km/h.

Gear 2 and Gear 3 are designed for slope operation for better gradeability, select gear 2 for forward slope operation and gear 3 for reverse slope operation.

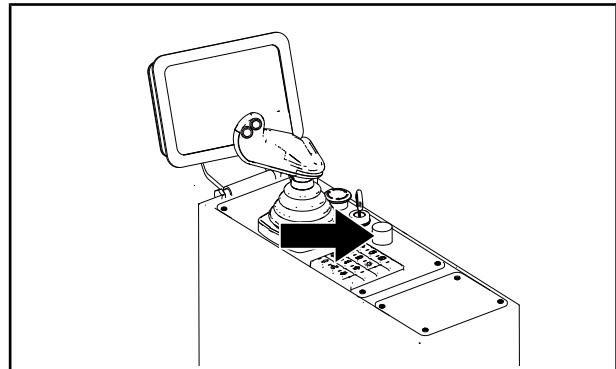

Fig 3-11

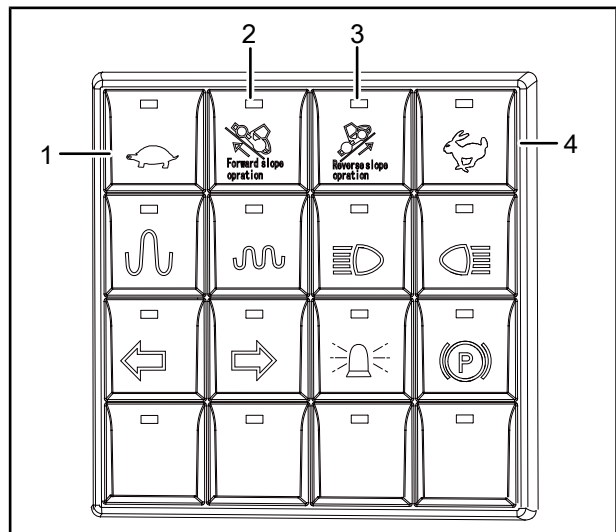

Fig 3-12

- 1. Gear 1
- 2. Gear 2
- 3. Gear 3
- 4. Gear 4

NOTICE
<p>Risk of machine damage! Shifting gear while the drum is still vibrating could cause significant impact to the hydraulic system. Before changing gear, make sure the vibration has gone to stop.</p>

Vibration frequency selection switch

There are two vibratory compaction frequencies: low frequency and large-amplitude, high frequency and small-amplitude. select different mode by pressing the two switches

NOTICE
<p>Risk of machine damage! Switching the frequency mode while the vibration has not gone to stop could cause significant impact to the hydraulic system. Before switching the frequency mode, make sure the vibration has gone to complete stop.</p>

Work lamp switch

Working lamp switch includes front working lamp switch and rear working lamp switch. When the visibility conditions are poor, press the switches to turn on the lamps.

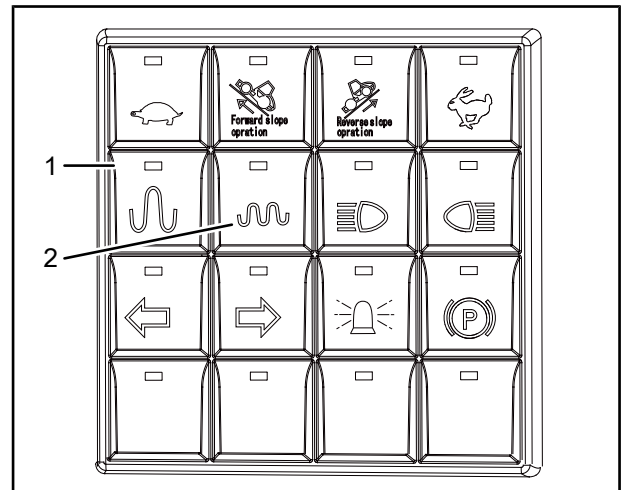

Fig 3-13

- 1. Low-frequency large-amplitude button
- 2. High-frequency small-amplitude button

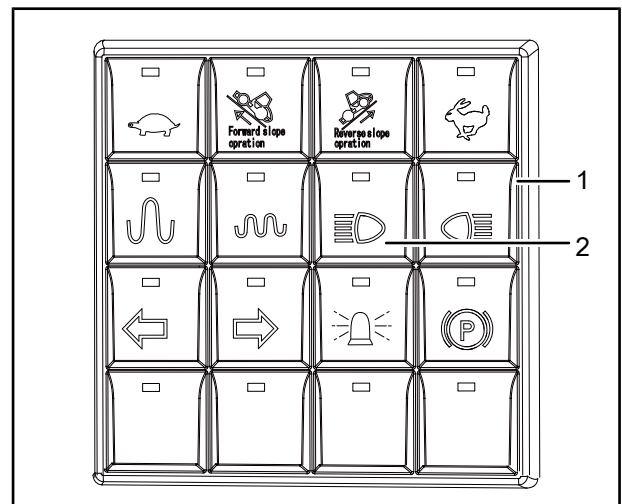

Fig 3-14

- 1. Rear working lamp switch
- 2. Front working lamp switch

Left/Right turn indicator switch

Press the switches to turn on the left and right turn lamps, press the switches again to turn off the left and right turn lamps.

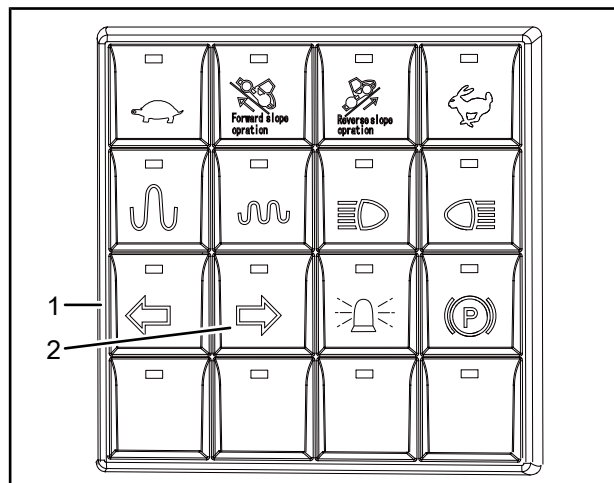

Fig 3-15

- 1. Left turn lamp switch
- 2. Right turn lamp switch

Warning lamp switch

Press the switch to turn on the warning lamp, press the switch again to turn off the warning lamp.

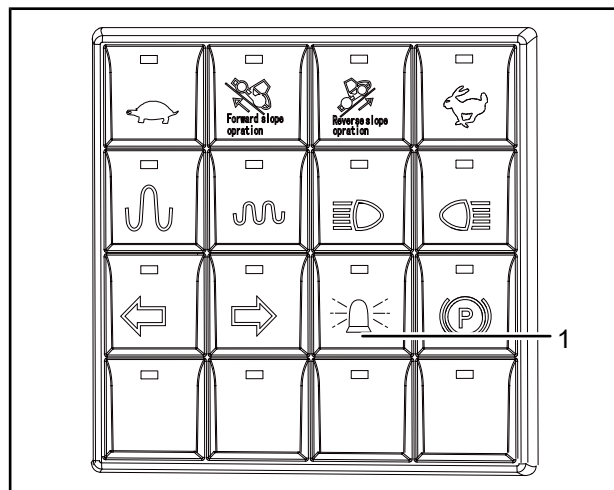

Fig 3-16

- 1. Warning lamp switch

Parking brake switch

Press the parking brake switch, and the parking brake will be enabled and the equipment cannot walk. Press it again to release the parking brake.

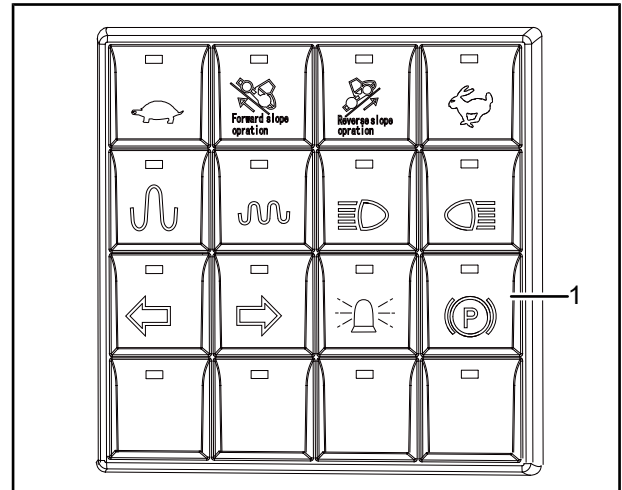

Fig 3-17

Front windshield wiper switch

Operate the front windshield wiper switch to control the front windshield wiper to get a clear visibility.

- Position (Up): the front windshield wiper works at Gear 2.
- Position (Middle): the front windshield wiper works at Gear 1.
- Position (Down): Stop working.

The figure shows the location of the front windshield wiper.

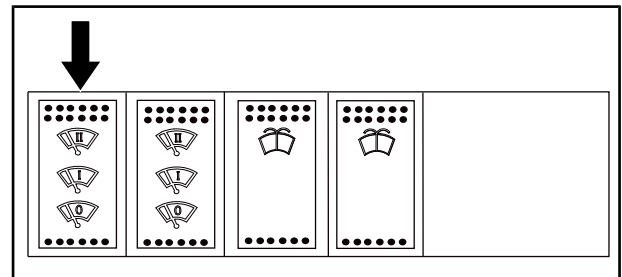

Fig 3-18

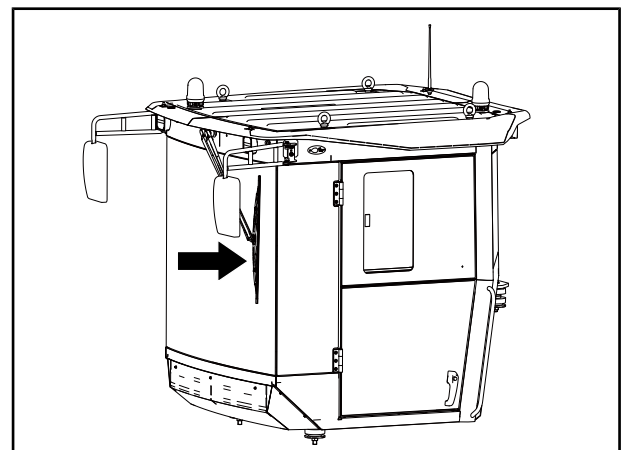

Fig 3-19

Rear windshield wiper switch

Operate the rear windshield wiper switch to control the rear windshield wiper to get a clear visibility.

- Position (Up): the rear windshield wiper works at Gear 2.
- Position (Middle): the rear windshield wiper works at Gear 1.
- Position (Down): Stop working.

The figure shows the location of the rear windshield wiper.

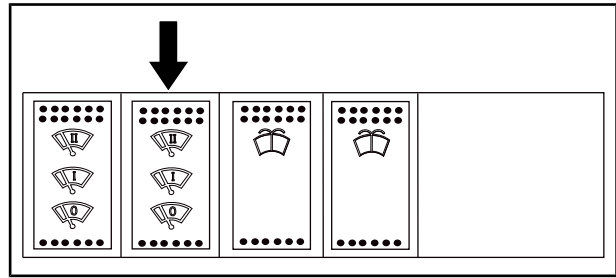

Fig 3-20

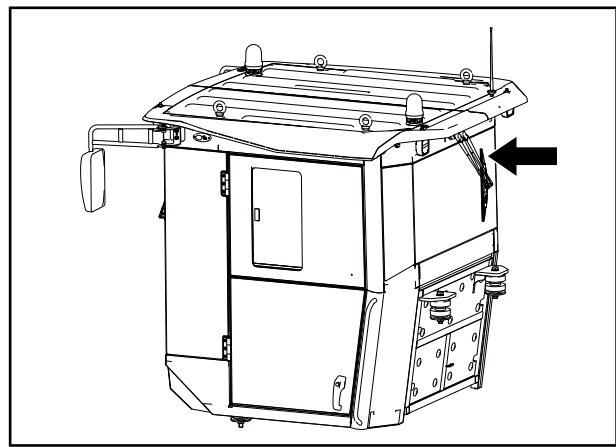

Fig 3-21

Front windshield washer switch

The front windshield washer switch is used to start or stop water spraying.

- Position (Up): The water spraying is on.
- Position (Down): The water spraying is off.

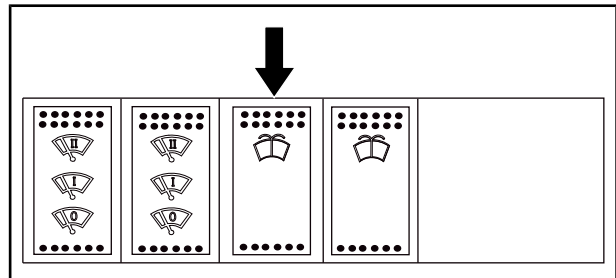

Fig 3-22

Rear windshield washer switch

The rear windshield washer switch is used to start or stop water spraying.

- Position (Up): The water spraying is on.
- Position (Down): The water spraying is off.

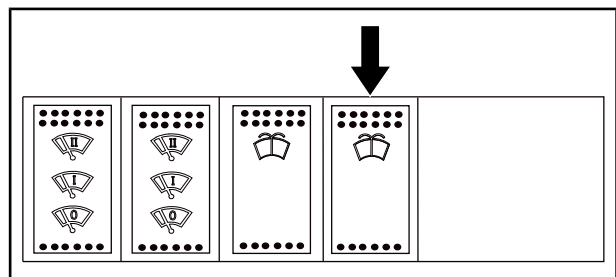

Fig 3-23

Every day before you operate the roller, you must check the water level of windscreen water tank. Once the water level is less than the 2/3 of the water tank, it should be filled it up. Assure sufficient antifreeze agent content.

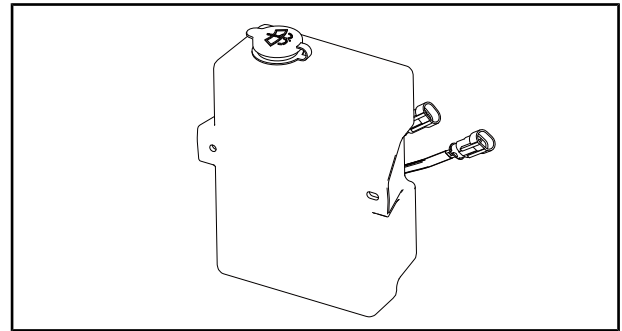

Fig 3-24

Dome lamp

The dome lamp is installed on the top in the front cab. Its switch is integrated on the lamp.

- Position (ON): The dome lamp is on.
- Position (OFF): The dome lamp is off.

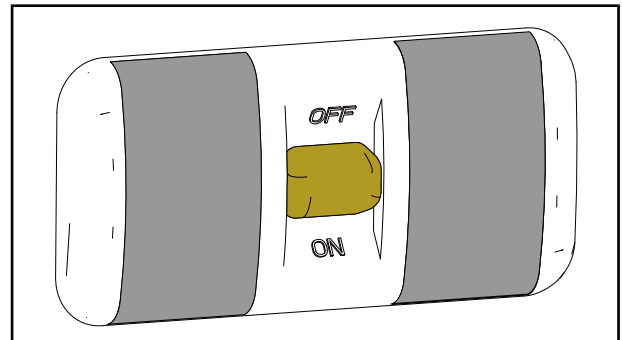

Fig 3-25

3.3 Display

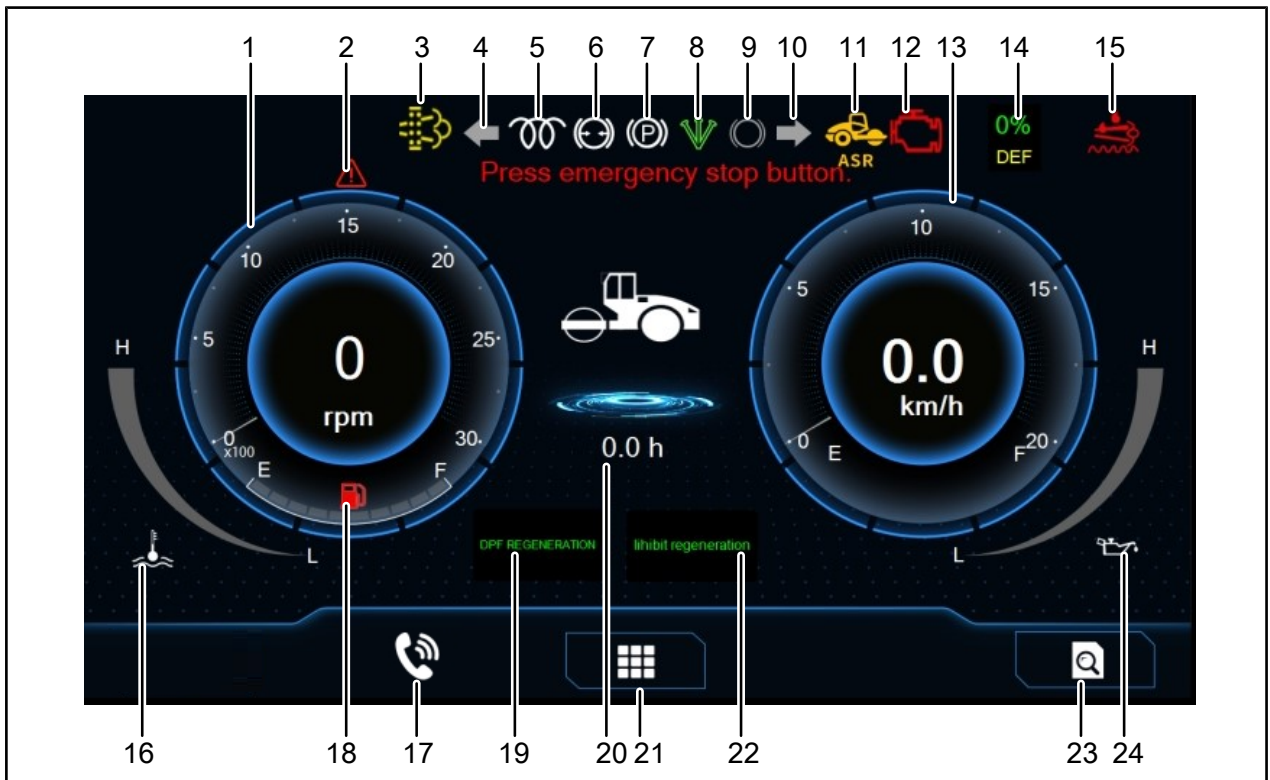

Fig 3-26

- | | | | |
|---------------------------------------|-------------------------------|----------------------------------|-------------------------------|
| 1. Engine tachometer | 8. Neutral position indicator | 15. After-treatment system alarm | 22. Inhibit regeneration |
| 2. Fault information | 9. Braking indicator | 16. Water temperature gauge | 23. Inquiry |
| 3. Regeneration | 10. Right turn indicator | 17. Contact information | 24. Engine oil pressure gauge |
| 4. Left turn indicator | 11. Anti-skid indicator | 18. Fuel level gauge | |
| 5. Preheating indicator | 12. Engine fault indicator | 19. DPF regeneration | |
| 6. Accumulator pressure low indicator | 13. Speedometer | 20. Hourmeter | |
| 7. Parking brake indicator | 14. DEF level indicator | 21. System menu | |

Engine tachometer

After startup, the engine tachometer on the display shows the engine speed. If the throttle gear is adjusted, the engine speed will change accordingly

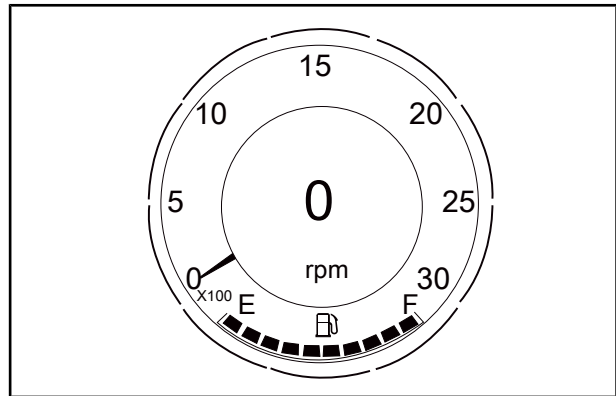

Fig 3-27

Fault information

The fault information will be displayed on the screen if any fault occurs.

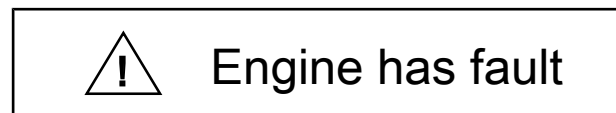

Fig 3-28

Regeneration

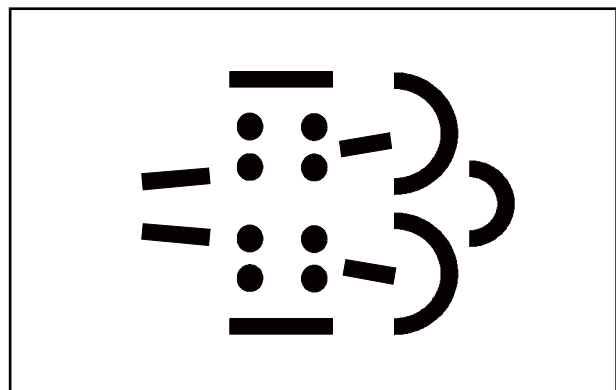

Fig 3-29

Left turn indicator

Fig 3-30

Preheating indicator

When preheating is enabled, the preheating indicator will be red.

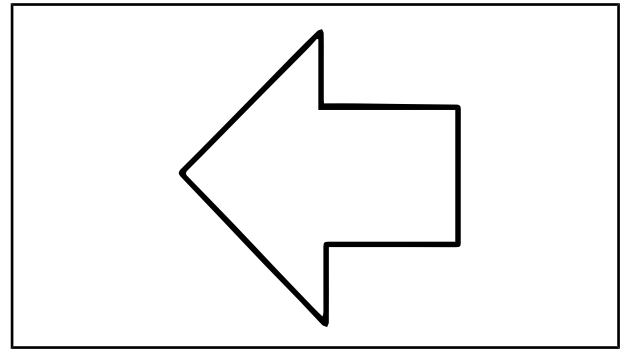
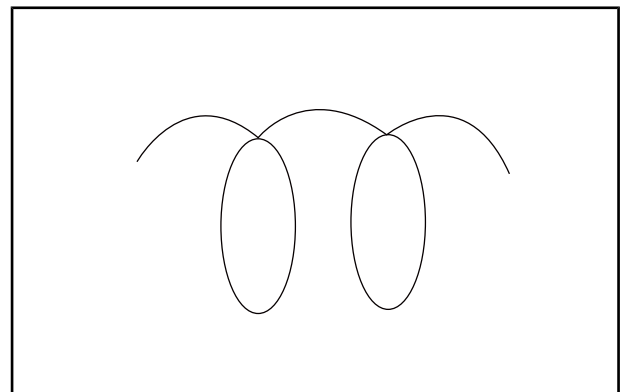

Fig 3-31

Brake pressure indicator

When the brake pressure is too low, it is in red.

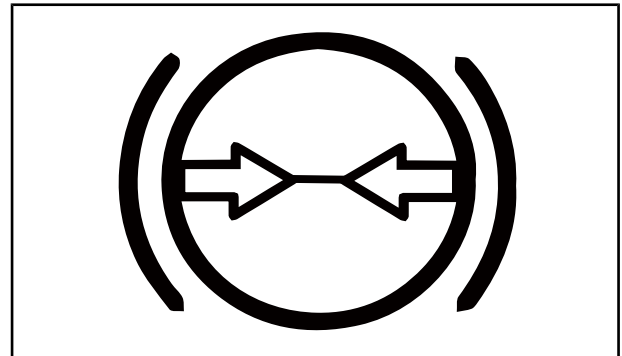

Fig 3-32

Parking brake indicator

If the indicator is in red, it indicates the parking brake is engaged.

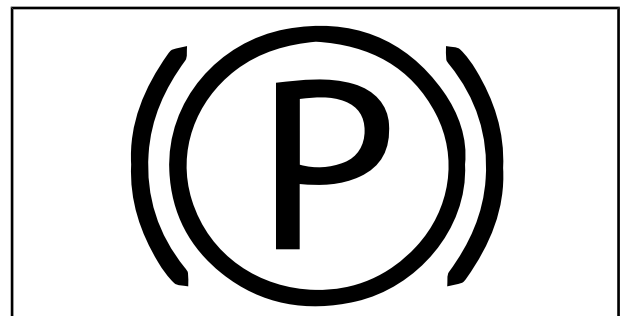

Fig 3-33

Neutral position indicator

When the propel level is in the neutral position, it lights up in green.

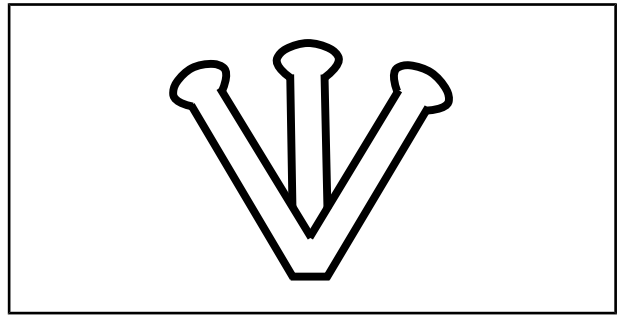

Fig 3-34

Braking indicator

If the indicator is in red, it indicates the brake is engaged.

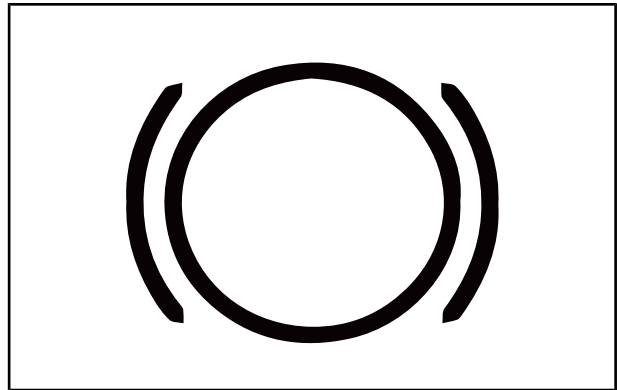

Fig 3-35

Right turn indicator

The right turn indicator flashes in green with the right turn light at a frequency. It indicates the status of the right turn light.

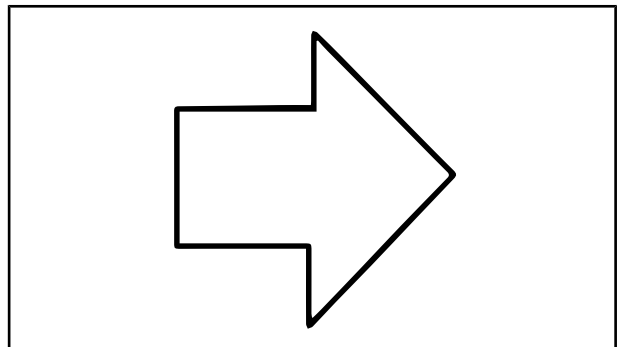

Fig 3-36

Anti-skid indicator

The indicator will be on if the anti-skid system is applied.

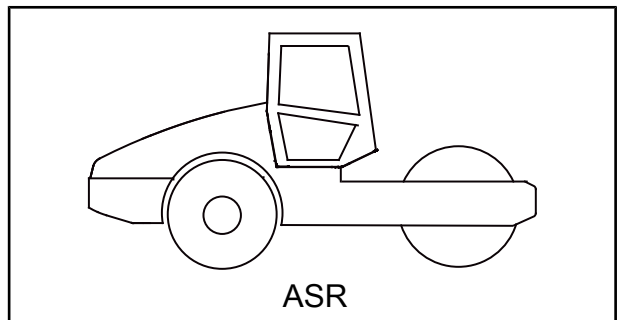

Fig 3-37

Engine fault

If the indicator is in red, it indicates the engine has fault.

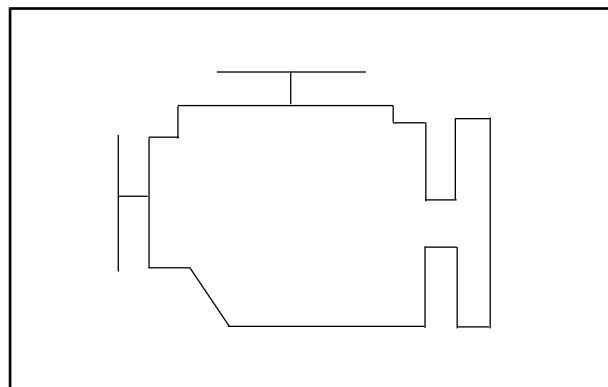

Fig 3-38

Speedometer

It displays the current equipment speedometer in real time.

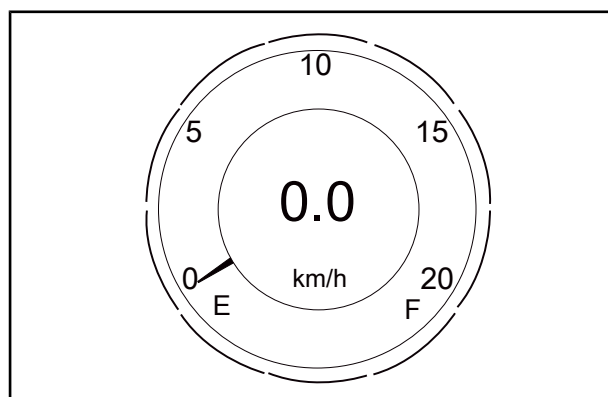

Fig 3-39

DEF level

The indicator indicates the DEF level.

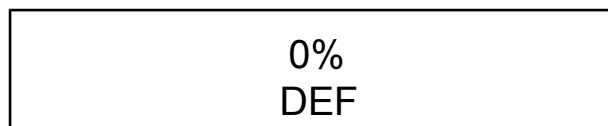

Fig 3-40

After-treatment system alarm

If the indicator is in red, it indicates the after-treatment system has fault.

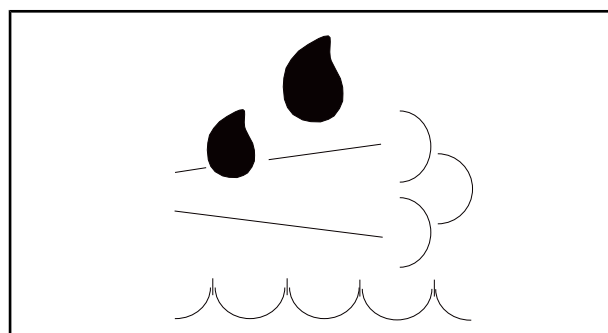

Fig 3-41

Water temperature gauge

The operator can observe the water temperature according to the progress bar above the water temperature high alarm indicator. When the water temperature is too high, a text prompt will appear above the display.

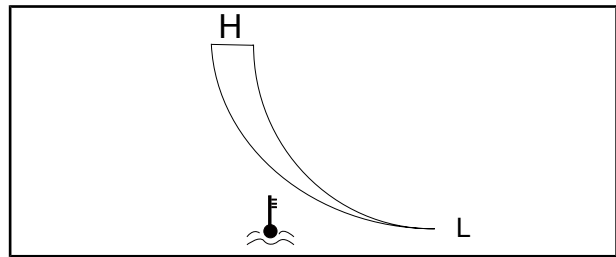

Fig 3-42

Fuel level gauge

It displays the current fuel oil level of the fuel tank in real time. If the fuel level is low, please replenish the fuel in time.

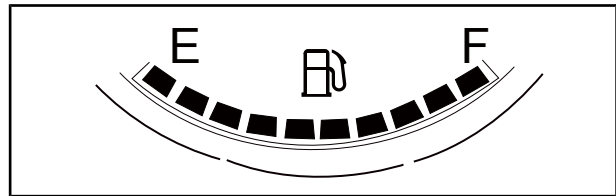

Fig 3-43

Engine oil pressure gauge

The engine oil pressure gauge indicates the engine oil pressure on a real time basis. If the engine oil pressure is too low, the prompt will be showed on the display.

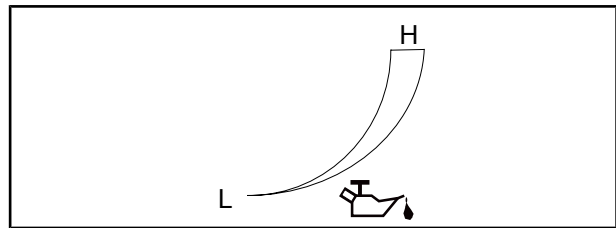

Fig 3-44

Hourmeter

The hourmeter is used to record the working hours of the engine, providing the basis for repair and maintenance.



Fig 3-45

Contact information page

1. Click the icon shown in the figure and input password to enter the contact information page.



Fig 3-46

2. In the event that you need to contact us for any reason, you can reach us.



Fig 3-47

System setting page

Click the icon shown in the figure and input password to enter the system setting page.

NOTE :

The system setting page are only available for Sany service personnel.



Fig 3-48

Inquiry page

Click the icon shown in the figure to enter the inquiry page. the customers can get the following information.



Fig 3-49

1. Analog value input/output 1

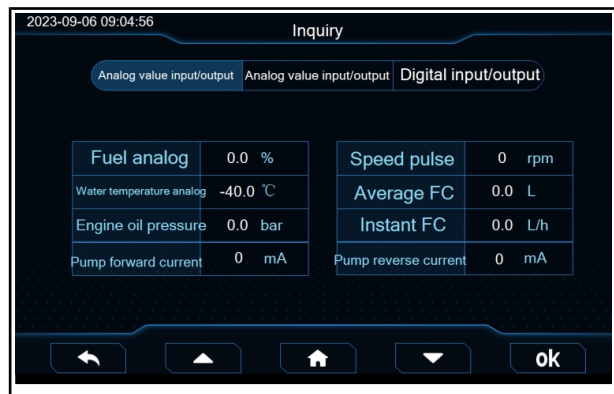

Fig 3-50

2. Analog value input/output 2

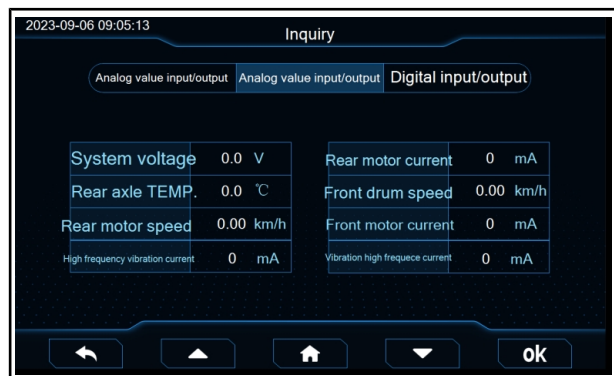

Fig 3-51

3. Digital input/output

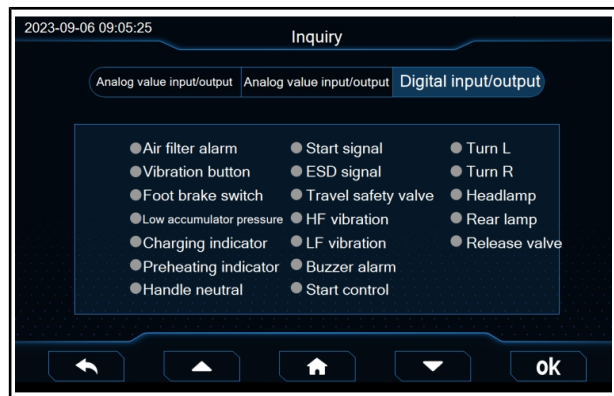

Fig 3-52

4. Work record



2023-09-06 09:08:48 Work record

boot time	0.0	H
Total fuel	0.0	L
Construction time	0.0	H
Construction fuel consumption	0.0	L
Standby time	0.0	H
Standby fuel	0.0	L

Navigation buttons: back, up, home, down, ok

Fig 3-53

5. ECU fault code

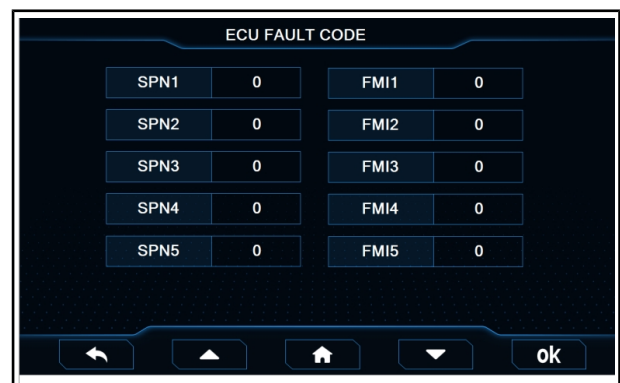

ECU FAULT CODE

SPN1	0	FMI1	0
SPN2	0	FMI2	0
SPN3	0	FMI3	0
SPN4	0	FMI4	0
SPN5	0	FMI5	0

Navigation buttons: back, up, home, down, ok

Fig 3-54

6. ACU error code



ACU ERROR CODE

SPN1	0	FMI1	0
SPN2	0	FMI2	0
SPN3	0	FMI3	0
SPN4	0	FMI4	0
SPN5	0	FMI5	0

Navigation buttons: back, up, home, down, ok

Fig 3-55

7. Anti-skid mode

Turn on/off the anti-skid mode by clicking the screen

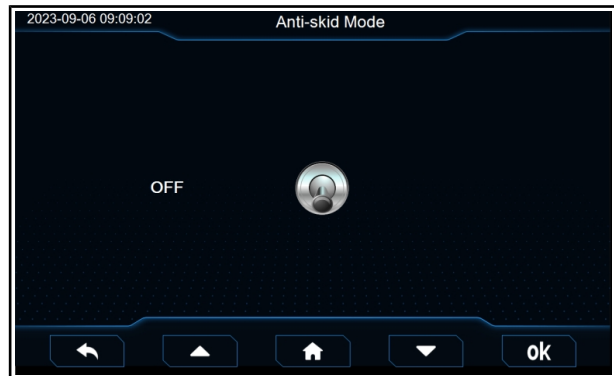

Fig 3-56

NOTE :

This machine is equipped with reversing camera, when the propel lever is pulled backward, the reversing camera is on and the image will be shown on the display. Press the key F2 under the display to turn off the reversing camera and F3 to turn on it.

3.4 A/C Panel

The air conditioner is mainly composed of evaporator, condenser, compressor, heat exchange valve and control panel. It can be used for cooling and warming. The control panel is at the left front side of the cab top.

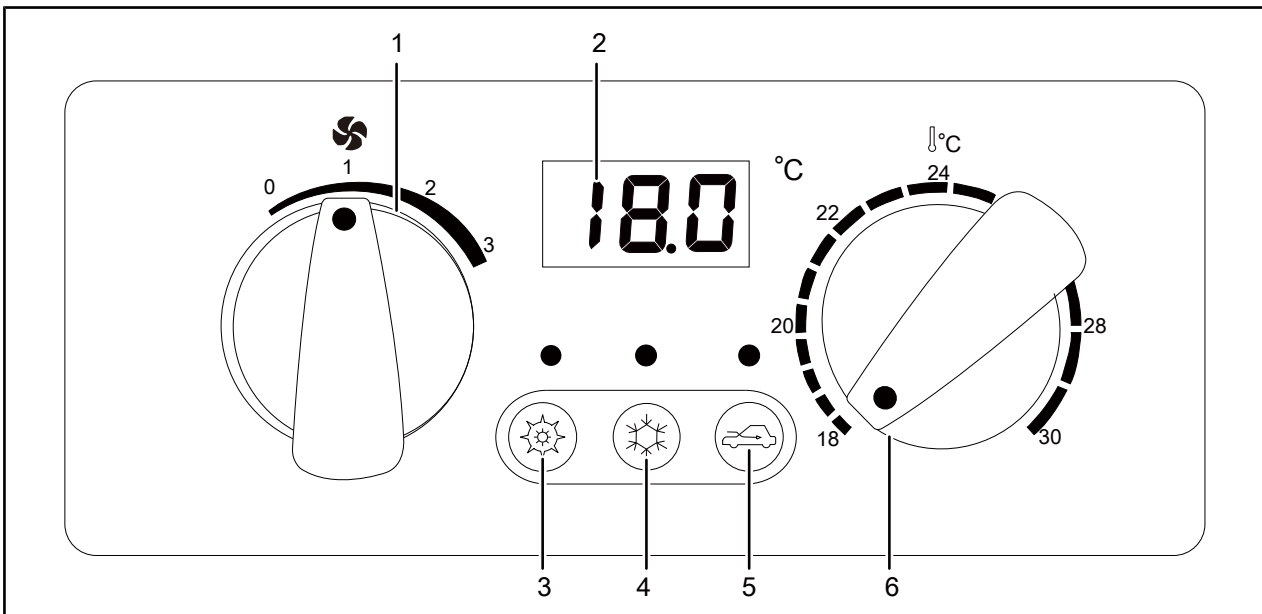
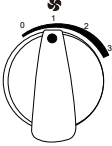

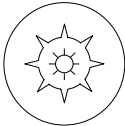
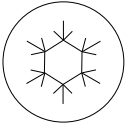
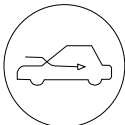
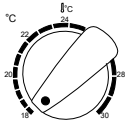

Fig 3-57

- 1. Fan speed control switch
- 2. Display
- 3. Warm mode switch
- 4. Cool mode switch
- 5. Outer air circulation switch
- 6. Temperature control switch

Table 3-1 Instruction for A/C Switches

Switch	Icon	Function	Operation
Fan speed control switch		To turn on/off the A/C system	When the switch is turned at 0 gear, the A/C system is off. When the switch is turned at other gears, the A/C is on; There are three gears. The 1 st gear stands for minimum fan speed and the 3 rd gear stands for maximum fan speed.
Display		To show the room temperature and fault code	When the system is on, the display shows the room temperature 5 seconds after there is on operation on the system.
Warm mode switch		To turn on/off the electrical water valve	The switch is to turn on/off the warm mode. When the A/C system is on, press the switch to turn on the warm mode.
Cool mode switch		To turn on/off the air compressor	The switch is to turn on/off the cool mode. When the A/C system is on, press the switch to turn on the cool mode.
Outer air circulation switch		To start the air circulation inside and outside the machine	The switch is to turn on/off the outer air circulation. When the A/C system is on, press the switch to start the outer air circulation for fresh air. Press the switch again to turn the outer air circulation off.
Temperature control switch		To set the room temperature	The room temperature range is 18°C-30°C

NOTICE

Risk of the machine damage!

When the A/C is in use, turn the temperature control switch to the "COOL" position while the fan speed control switch is at the "L" position could lead the evaporator to frost.

Do not turn the temperature control switch to the "COOL" position while the fan speed control switch is at the "L" position, and open all the air outlets.

3.5 Radio

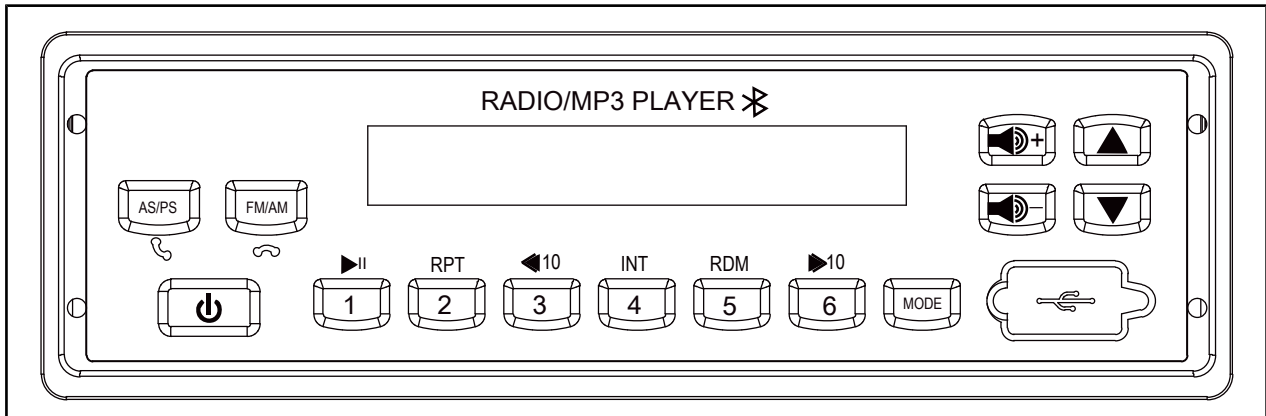

Fig 3-58

Table 3-2 Key Function

Key	State	Basic Operation	Function Description
POWER	RADIO/USB/BT	Short press	Turn on/Mute (After turn on)
		Long press	Turn off
FM/AM	RADIO	Short press	Radio channel switch
	BT on the phone	Short press	Hang up phone
	RADIO/USB/BT	Long press	BAS/TRE/BAL select adjust function
AS/PS	RADIO	Short press	Browse radio station stored in M1~M6
		Long press	Save station after automatically searching
	BT on the phone	Short press	Put phone through
MODE	RADIO/USB/BT	Short press	Switching in RADIO/USB/BT mode
VOL —/+	RADIO/USB/BT	Short press	Volume control/BAS/TRE/BAL adjust function
▲ ▼	RADIO	Short press	Forward / backward automatic Search radio frequency
		Long press	Manual search radio frequency
	USB/BT music	Short press	Upper/Next

Table 3-2 Key Function (continue)

Key	State	Basic Operation	Function Description
1/Pause	RADIO	Short press	Load station 1 frequency
		Long press	Store frequency into station 1
	USB/BT music	Short press	Pause/play
	BT on the phone	Short press	Mobile, Radio phone switch
2/RPT	RADIO	Short press	Load station 2 frequency
		Long press	Store frequency into station 2
	USB	Short press	Turn on / off single repeat function
3/-10	RADIO	Short press	Load station 3 frequency
		Long press	Store frequency into station 3
	USB/BT music	Short press	Upper 10
4/INT	RADIO	Short press	Load station 4 frequency
		Long press	Store frequency into station 4
	USB/BT music	Short press	Browse and play
5/RDM	RADIO	Short press	Load station 5 frequency
		Long press	Store frequency into station 5
	USB/BT music	Short press	Random play
6/+10	RADIO	Short press	Load station 6 frequency
		Long press	Store frequency into station 6
	USB	Short press	Next 10

NOTE :

Press AS/PS two seconds to search and save station.

Radio operation

- Radio Mode
 - Default radio mode in the first time device turn on. In USB play mode, press [MODE] switch to radio mode.
- Band selection
 - Short press [FM/AM], enter in turn FM1/FM2/FM3/AM1/AM2 band.
- Automatically search station and store station
 - Long press [AS/PS], start automatically search station and store station, stations store in [1~6].
- Manual search station
 - Long press [◀] and [▶] can manual search station backward or forward until find the station.

NOTE :

When the overall signal intensity is weak, the manual search station may turn into the noise station because of its high sensitivity.

- Manual sharp turning station
 - Short press [◀] or [▶], can manual sharp turning station frequency.
- Manual store station
 - After press above step 4 and step 5 to find the station, long press(3 seconds) one of [1~6], then store the station into the Corresponding place [1~6].
- Preset station
 - Press station [1~6], turn into preset station under corresponding frequency.

USB operation

- In radio mode, press [MODE] tune into USB mode.
 - Insert U disk, automatically search MP3 and play, short press[◀] or[▶], play last or next track.
- U disk/RADIO select
 - Press [MODE], switch USB/RADIO mode.
- Play/Pause control
 - In USB mode, short press[1] to play or pause.

- [Mode] key
 - In RADIO/USB state, long press [Mode] to show clock.
- Browse play track
 - In USB mode, short press [4/INT], 'INT' display on the screen, can browse U disk, play 5 second for each song.
- Repeat
 - Short press [3/RPT] to repeat. 'RPT' display on the screen.
- Random play
 - Short press [4/RDM], 'RDM' display on the screen, random play MP3.
- Upper/Next10
 - In USB mode, press[3/-10] or [6/+10], select play upper or next 10 of MP3.

Basic operation of bluetooth

NOTE :

Name is CAR KIT. Default password is 0000.

- Key function
 - Press“2”: Disconnect bluetooth device.
 - On phone status.
 - ◆ Press“1”: Voice switching between bluetooth and mobile phone.
 - ◆ Press AS/PS : Answer the phone.
 - ◆ Press FM/AM : Hang up phone.
- Music status
 - Press“1”: Music play/pause.
 - Press“PRE”▲: Upper song.
 - Press “NEXT”▼: Next song.

SANY

Operation

4 Operation	4-1
4.1 Check before Starting the Engine.....	4-3
4.1.1 Inspection (Walk-around).....	4-3
4.1.2 Inspection before Starting.....	4-3
4.2 Adjustments Prior to Startup.....	4-6
4.2.1 Seat Adjustment.....	4-6
4.2.2 Rearview Mirror Adjustment.....	4-11
4.3 Equipment Check Prior to Startup.....	4-11
4.3.1 Introduction.....	4-11
4.3.2 Power on the Control System.....	4-12
4.3.3 Check the Fuel Level.....	4-12
4.3.4 Check the Diesel Exhaust Fluid (DEF) Level.....	4-13
4.3.5 Check the Propel Control Lever.....	4-13
4.3.6 Check the Emergency Stop Switch.....	4-13
4.3.7 Check the Parking Brake Switch.....	4-14
4.3.8 Check the Switches.....	4-14
4.4 Engine Starting.....	4-15
4.4.1 Normal Start.....	4-15
4.4.2 Jump-Start.....	4-16
4.4.3 Engine Start in Cold Weather (Optional).....	4-16
4.5 After Engine Starting.....	4-17
4.6 Test Running.....	4-17
4.7 Travel Operation.....	4-18
4.7.1 Travel Forward.....	4-18
4.7.2 Travel Backward.....	4-18
4.8 Vibration Operation.....	4-19
4.9 Parking Operation.....	4-21
4.9.1 Service Brake.....	4-21
4.9.2 Park Brake.....	4-21

4.9.3 Emergency Brake.....	4-22
4.10 Correct Driving According to the Road Condition	4-23
4.10.1 Working near Ditch Edge and Road Shoulder.....	4-23
4.10.2 Working near Buildings Vulnerable to Vibration	4-24
4.10.3 Working on the Slope	4-24
4.11 Check after Each Work Day	4-25
4.12 Transportation	4-25
4.12.1 Transport Vehicle	4-25
4.12.2 Using a Slope	4-25
4.12.3 Shipping	4-26
4.12.4 Towing Information	4-31

4.Operation

4.1 Check before Starting the Engine

4.1.1 Inspection (Walk-around)

- Check the motors, cylinders, hoses for cracks, excessive wear or looseness. Repair or replace it according to the fact.
- Remove the dirt and debris around the engine, battery and radiator. Check the surrounding of engine and radiator for buildup of dirt. Check the surrounding of muffler, turbocharger or other hot components for flammable materials like dry leaves and thin branches. Remove them if any dirt or flammable materials are found.
- Check for any leaks of coolant or oil around the engine. Repair it in case of any problem.
- Check the hydraulic unit, hydraulic tank, hoses and joints for any leaks of oil. Repair the leaks if any.
- Check the handrails and step for any problem like loose bolts. Repair it in case of any problem.

4.1.2 Inspection before Starting

1. Check the engine oil level

The steps for checking engine oil have been described. **See** [“Engine Oil-Check/Refill/Change” on page 5-26.](#)

2. Check the coolant level of the engine

The steps for checking the engine coolant level have been described. **See** [“Engine Coolant-Check/Change” on page 5-34 .](#)

3. Check the oil water separator

The steps for checking oil water separator have been described. **See** [“Oil Water Separator–Check/Drain/Replace” on page 5-29.](#)

Besides, check the hoses and pipe connector for looseness to avoid the air going into the pipeline.

4. Check the hydraulic oil level

The steps for checking the hydraulic oil level have been described. **See** [“Hydraulic Oil-Check/Refill/Change” on page 5-41 .](#)

NOTE :

The oil level will change after startup of engine, check the level again before working.

NOTE :

The oil level may change as the oil temperature varies. While in operation, keep the oil level about 2/3 of the level meter.

5. Check the washer

The container of washer is mounted at the rear right side in the cab.

The steps for checking the fluid level have been described. See [“Windshield Washer Fluid–Check/Fill” on page 5-57](#) .

6. Check the air filter

Take the following steps to remove the accumulated dust.

- 1)Open the access door at the side of the engine hood, and then the air filter can be seen.
- 2)Empty dust by pressing the dust evacuator (1).
- 3)Close the access door.

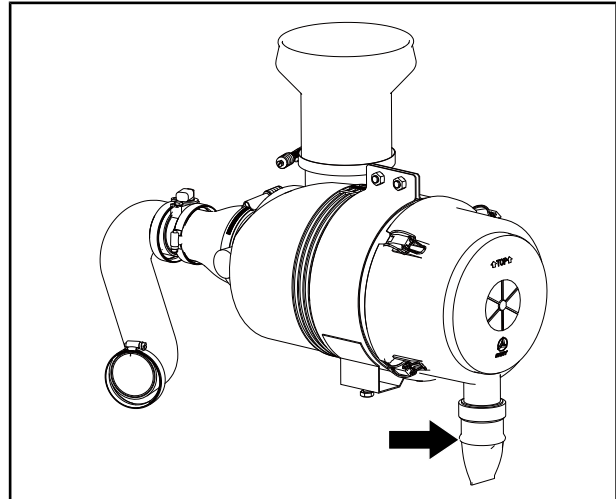

Fig 4-1

1. Dust evacuator

7. Check the tires

- Check every tire (1) for proper inflation, excessive wear, damaged or cut surface and foreign matter penetration.
- Check every rim (2) for loose or missing lug nuts and damaged surfaces.

NOTE :

If any problems with the tires or rims are found, contact your SANY distributor for repairs.

Tire pressure

NOTICE
<p>Risk of tire blowing up! The tire pressure could increase if the tire is exposed to the sun. Too much inflation on pressure could cause the tire to blow up. Avoid the tire exposed to the sun.</p>

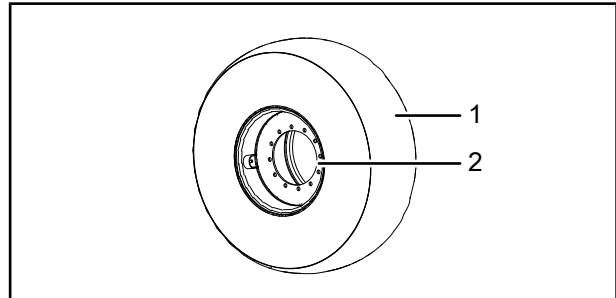

Fig 4-2

1. Tire

2. Rim

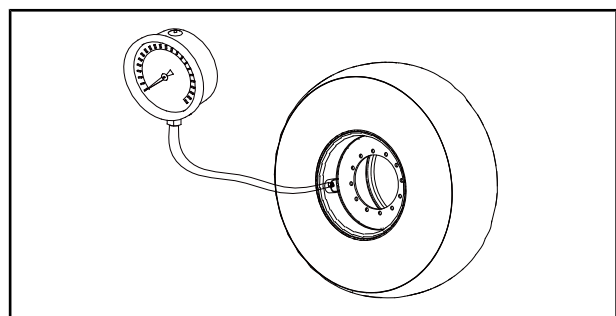

Fig 4-3

Check the tire pressure with a pressure gauge. Generally, the range of tire pressure should be 1.4 ± 0.3 kgf/cm². When the tire pressure is lower, you have to charge the tires. The recommended maximum pressure shall be 1.7 kgf/cm².

8. Check the position of limit plate

Make sure the limit plate for front and rear frames is unlocked, otherwise the roller cannot steer.

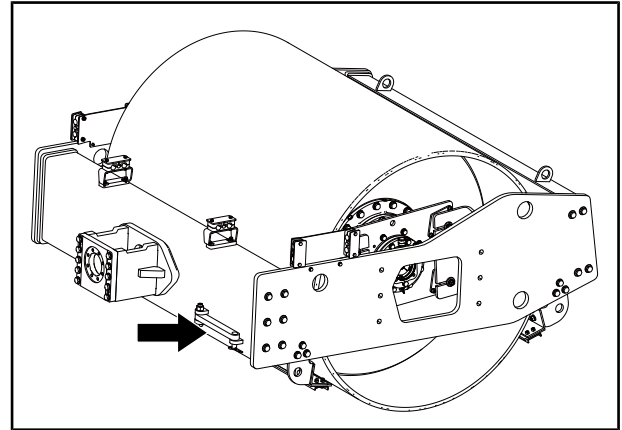

Fig 4-4

9. Check the vibratory drum and dampers

Steps for checking drums and dampers have been given. See [“Damper-Check/Replace” on page 5-57](#).

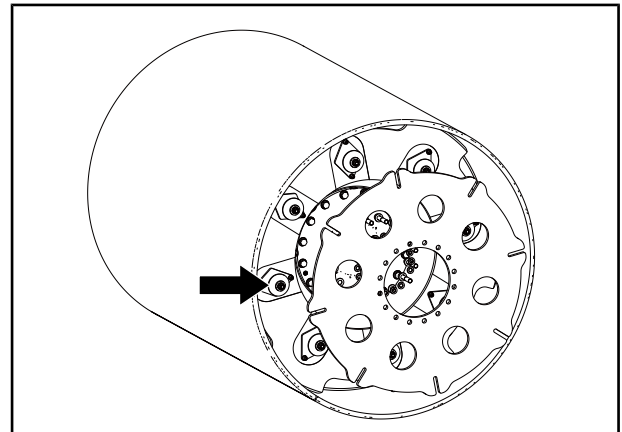

Fig 4-5

10. Check the cables

NOTE :

If any fuse burns frequently or any cable shows the sign of short circuit, contact SANY distributor to find the cause and how can it be eliminated. If not, this will affect the control system chronically.

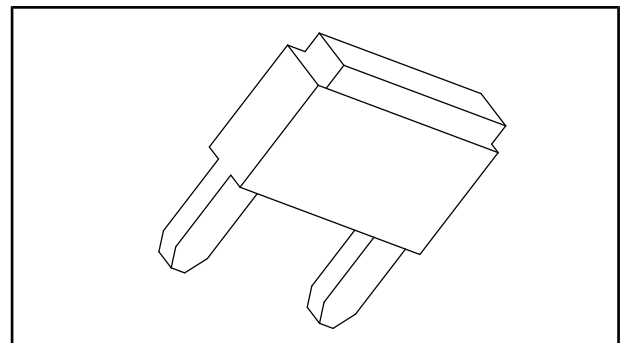

Fig 4-6

Check whether the fuse is damaged; whether the fuse with proper capacity is used; whether any wire connection is off. Check for loose terminals. Fix it if any.

Moreover, pay special attention to the cables when checking battery, engine, starter motor and alternator. Make sure to check for flammable materials around battery. Immediately remove them if any.

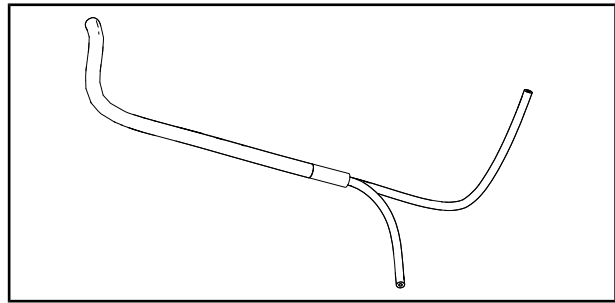

Fig 4-7

4.2 Adjustments Prior to Startup

4.2.1 Seat Adjustment

This machine is equipped with a fully adjustable seat. To prevent operator fatigue, adjust the seat to the correct position for the current operator.

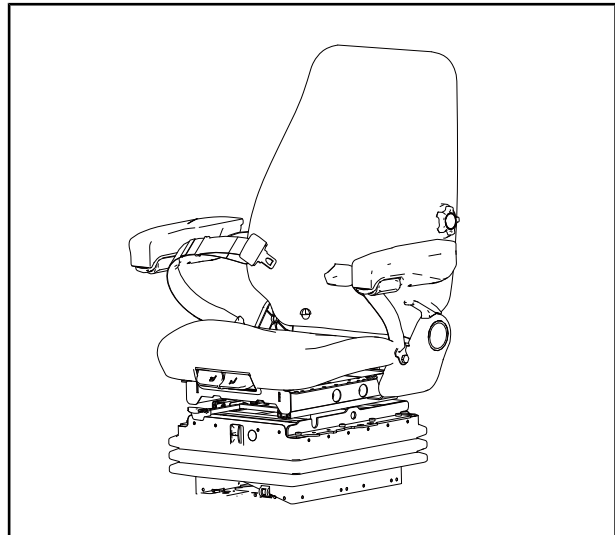

Fig 4-8

This seat is equipped with seat contact switch, once the operator leaves the seat, prompt will appear on the display. If the operator leaves the seat for more than three second, the roller will stop both travelling and vibration. The roller will return to normal operation after the operator sits down.



Fig 4-9

NOTE :

Incorrect sitting position such as only sitting at the front area of the seat will activate the protection program too since the sensing area covers about half of the seat. The operator should sit at the area shown in the right figure to avoid this situation.

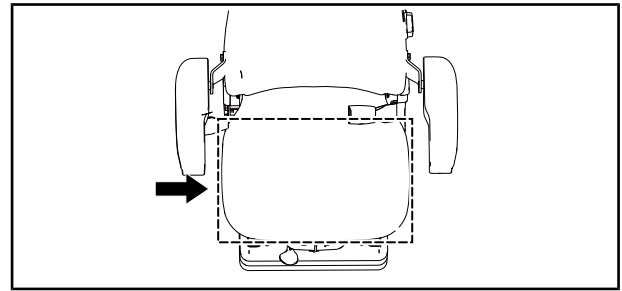

Fig 4-10

Seat Backrest Angle Adjustment

1. When seated, lift and hold the backrest adjustment lever (1) on the lower left side of the backrest.
2. Lean forward or backward to move the backrest to the desired position.
3. Release the lever to lock the backrest in position.

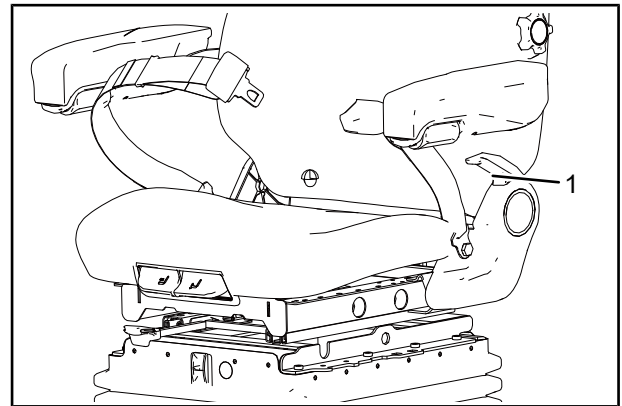

Fig 4-11

1. Backrest adjustment lever

Lumbar Support Adjustment

When seated, turn the lumbar support knob (1) clockwise to lift the lumbar support or counterclockwise to lower the lumbar support to suit operator comfort.

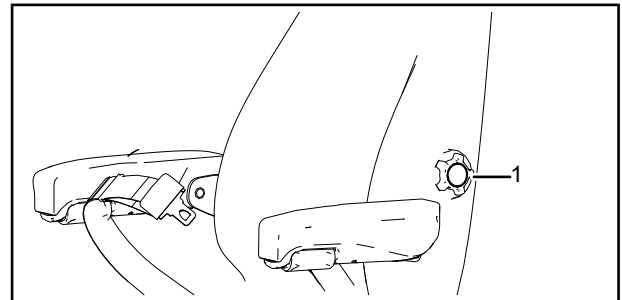

Fig 4-12

1. Lumbar support knob

Armrest Angle Adjustment

When seated, turn the knob (1) under the armrest to adjust the angle of the armrest to the desired position. Turn the knob (1) inward to lower the front of the armrest and outward to lift the front of the armrest. Either armrest can be placed vertically so that the operator can easily exit the seat.

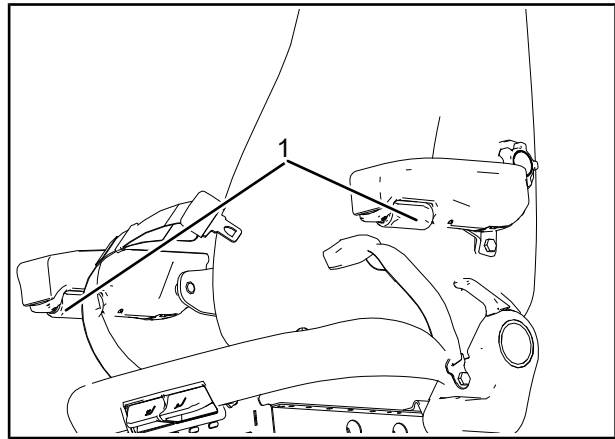

Fig 4-13

1. Knob

Seat Cushion Forward and Backward Adjustment

1. When seated, lift and hold the seat cushion adjustment lever (1) and slide the seat cushion forward or backward to the desired position.

2. Release the lever to lock the seat cushion in position.

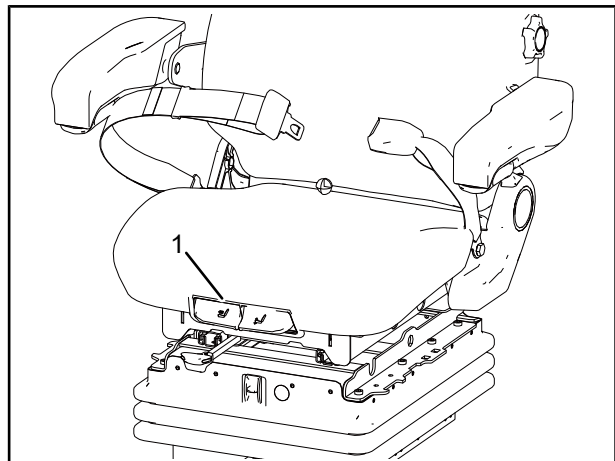

Fig 4-14

1. Seat cushion adjustment lever

Seat Tilt Adjustment

1. When seated, lift and hold the seat tilt adjustment lever (1) and tilt the seat forward or backward to the desired angle.
2. Release the lever to lock the seat cushion in position.

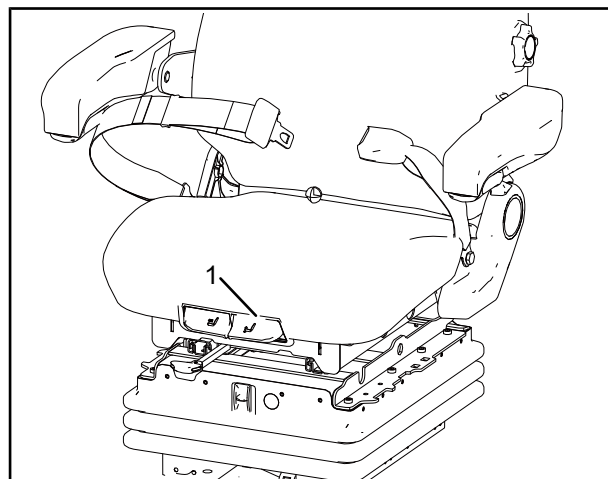

Fig 4-15

1. Seat tilt adjustment lever

Seat Forward and Backward Adjustment

1. When seated, lift and hold the seat adjustment lever (1) and slide the seat forward or backward to the desired position.
2. Release the lever to lock the seat in position.

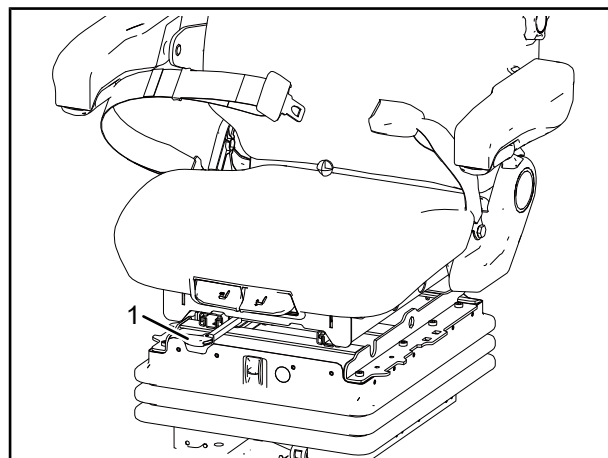

Fig 4-16

1. Seat adjustment lever

Weight Adjustment

Move the weight adjustment switch (1) upward to inflate the airbag and increase the weight capacity; Move the weight adjustment switch (1) downward to discharge the airbag and decrease the weight capacity

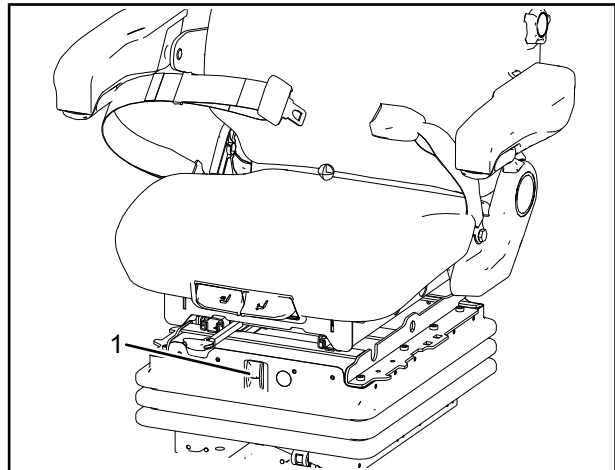

Fig 4-17

1. Weight adjustment switch

Seat Belt

⚠ WARNING

- Inspect the seat belt. Replace the seat belt immediately if the webbing is frayed or cut, if the buckle is damaged or malfunctions, or if the mounting hardware is loose. Replace according to seat belt manufacturer’s instructions.
- Always keep the seat belt fastened during machine operation. Never twist the seat belt when fastening it.

Failure to follow these warnings could result in death or serious injury

1. Grasp the latch plate (1) and pull upward to lengthen the belt. Insert the latch plate into the buckle (2) until it locks.

2. The belt should be placed as low as possible on your hips, not on your waist. The belt will retract to adjust belt slack.

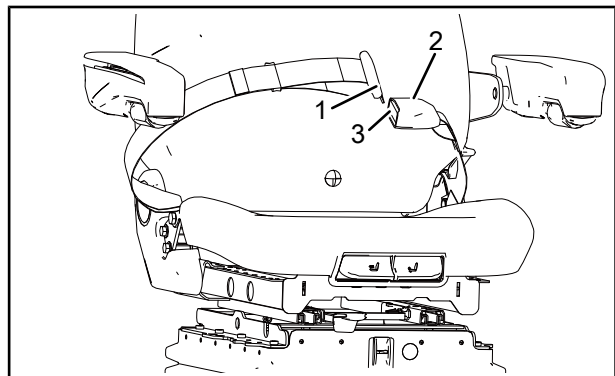

Fig 4-18

1. Latch plate 3. Red button
2. Buckle

⚠ WARNING

Keep belt slack to no more than 1 in. (25 mm). Belt slack beyond this amount could significantly reduce your protection in an accident. Failure to follow this warning could result in death or serious injury.

3. Press the red button (3) on the buckle to release the latch plate.

⚠ WARNING

Contact a SANY dealer if the seat belt fails any of these checks, or fails to fasten or unfasten. Failure to follow this warning could result in death or serious injury.

4.2.2 Rearview Mirror Adjustment

Adjust the left side rearview to observe the left side of roller and to check the distance between object and the left rear of the roller.

Adjust the right side rearview to observe the right side of roller and to check the distance between object and the right rear of the roller.

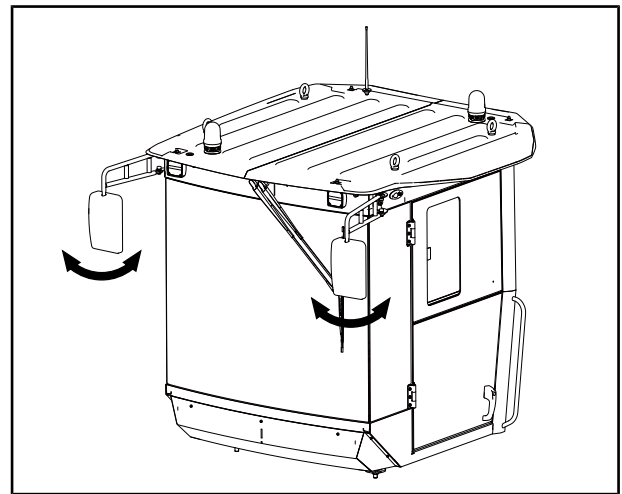

Fig 4-19

4.3 Equipment Check Prior to Startup

4.3.1 Introduction

Before starting up the engine, you need to check some equipment to see whether they are in good condition or not.

4.3.2 Power on the Control System

In order to check the equipment, first you have to power on the control system. Connect the master disconnecter switch of power supply. The position of the master power switch is shown in the right figure.

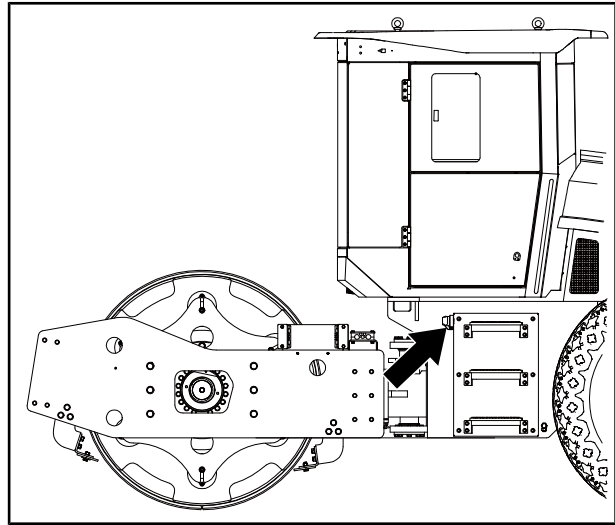

Fig 4-20

Insert the key, and turn to position "ON". So the control system will be powered on, and the display shows icons.

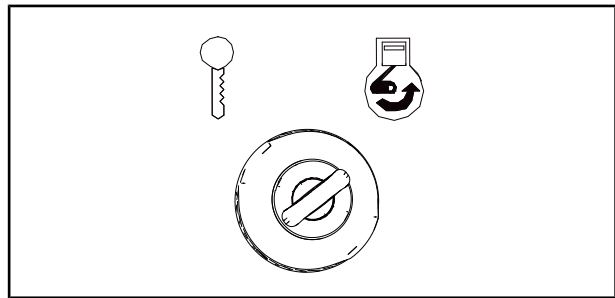

Fig 4-21

At this moment, if the park brake indicator, the neutral position indicator, the battery charging indicator and engine oil pressure indicator light up, while other indicators are off. This indicates the circuit is ready.



Fig 4-22

4.3.3 Check the Fuel Level

The steps for checking fuel have been described. [See “Fuel-Check/Refill/Replace” on page 5-37.](#)

4.3.4 Check the Diesel Exhaust Fluid (DEF) Level

Check the DEF level by observing the DEF level indicator on the display, volume in the DEF tank should not be less than 20%. Otherwise, you should add DEF. See [“Aftertreatment System - Check/Fill” on page 5-40](#).

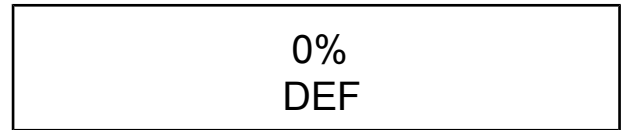

Fig 4-23

4.3.5 Check the Propel Control Lever

Before starting the engine, the propel control lever should be placed at STOP position, or else the roller will suddenly run when engine is started. And the impact will cause not only danger to the operator, but also harm to engine and pump.

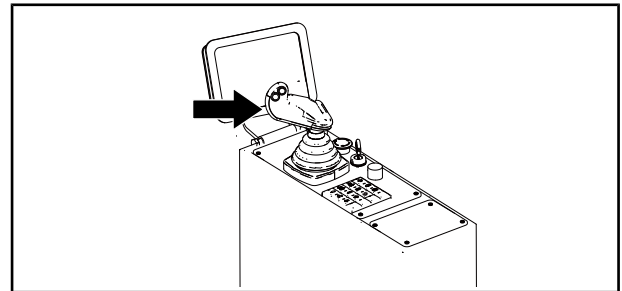

Fig 4-24

4.3.6 Check the Emergency Stop Switch

Before starting the engine, the emergency stop switch should be released, or else the engine can not be started.

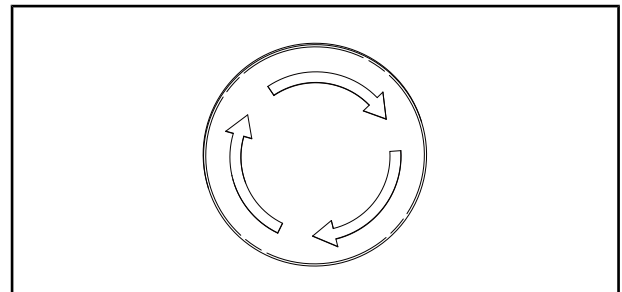

Fig 4-25

4.3.7 Check the Parking Brake Switch

Before starting the engine, the parking brake switch should be enabled and the indicator on the display. Fix if any problem appears.

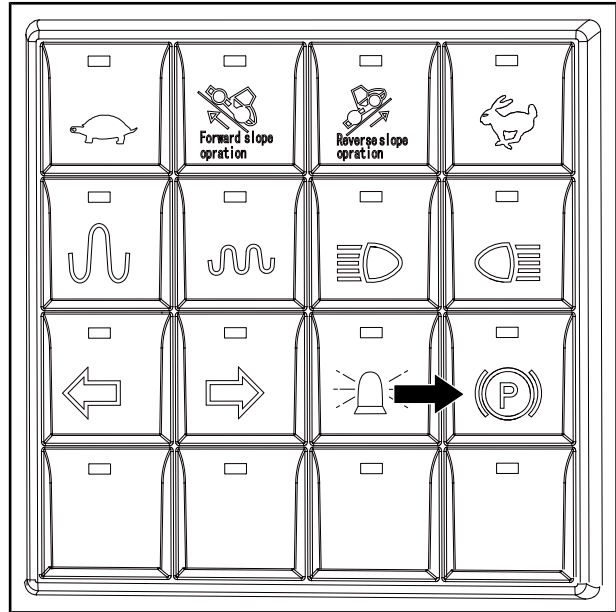

Fig 4-26

4.3.8 Check the Switches

Before starting the engine, check the switches, indicators and working device to see whether they are in properly working or not. Fix if any problem appears.

Switch panel

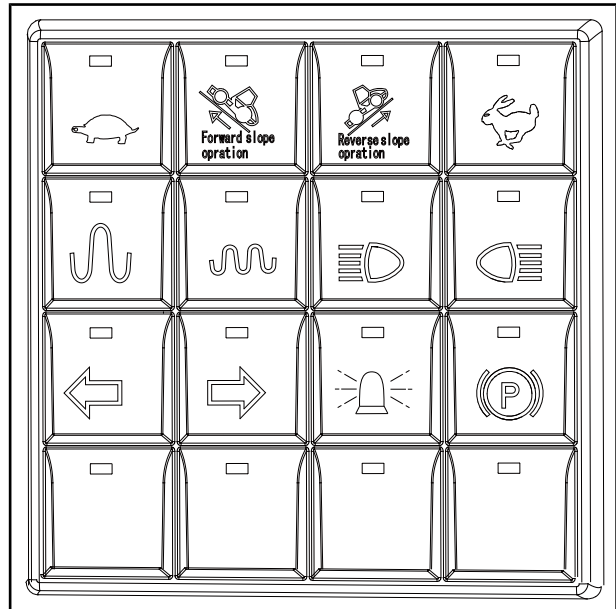

Fig 4-27

Horn

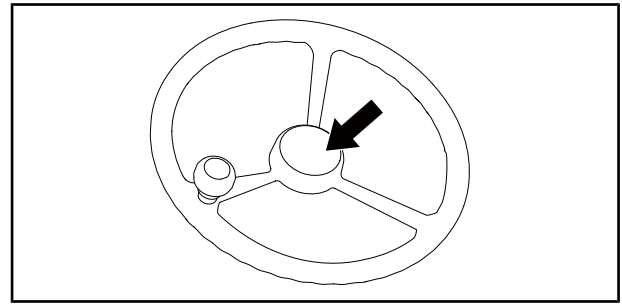

Fig 4-28

Wiper and the washer switches

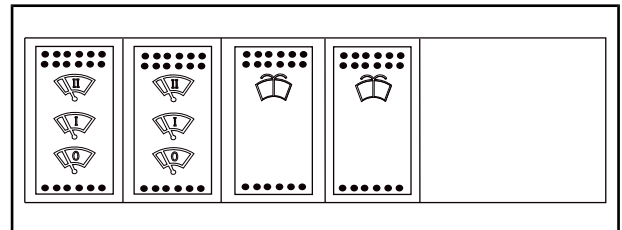

Fig 4-29

4.4 Engine Starting

4.4.1 Normal Start

Make sure that the display is initialized and there is no malfunction, you can start the engine.

1. Turn the key to the right end.

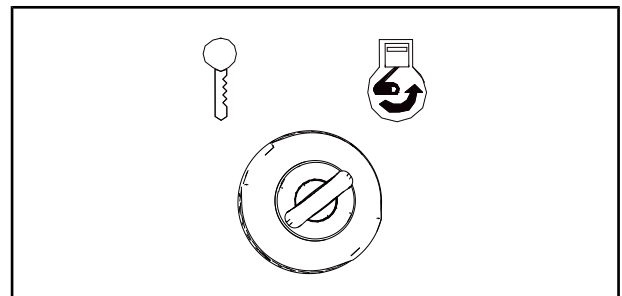

Fig 4-30

2. Hold the key at the right end.
3. Release the key immediately after the engine is started. The key will return to original position automatically.

4.4.2 Jump-Start

If the batteries are short of energy, you can start up the engine according to the steps as follows.

1. Using jumper cable to start engine requires two persons working together (One is seated in the operator's seat and the other handles the battery).

2. Wear goggles and rubber gloves when starting a machine with jump start cables.

3. Jump start with an energy source of the same voltage as the stalled machine.

4. When using jumper cables, connect the positive (+) jumper cable to the positive (+) battery terminal first. Next, connect the negative (-) jumper cable to the frame away from the batteries.

NOTE :

Do not allow the jump start cable ends to contact each other or the machine.

4.4.3 Engine Start in Cold Weather (Optional)

In cold weather, the engine may not be started as normal because of the low temperature. At this moment, you can warm up the engine before starting. Keep the key at the "II" gear for about 10s to preheat. After that, turn the key to the gear "III".

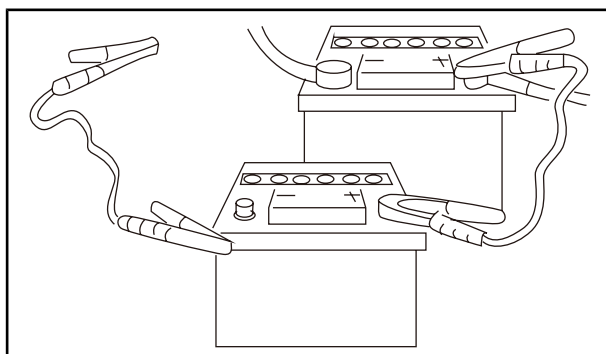

Fig 4-31

4.5 After Engine Starting

After starting the engine, the roller shouldn't be used to work at once. There should be 3 min - 5 min for the engine to run in idling speed.

Rotate the throttle control switch to the MIN position, then the engine will run in idle speed.

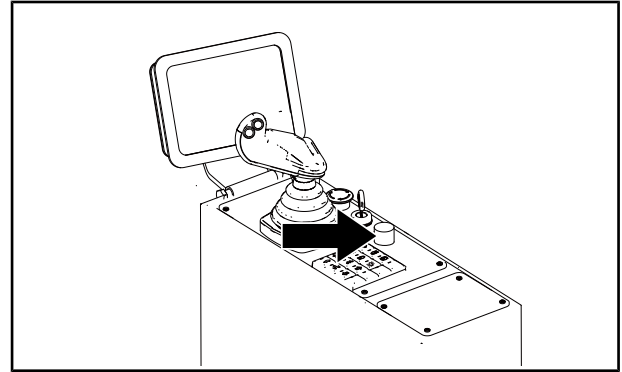

Fig 4-32

Observe the pressure gauges, instruments and warning lights to ensure they are properly functioning, with all readings within specific ranges.

NOTE :

After the engine is started up, generally the hydraulic oil level will be lower. If the hydraulic oil level is lower than 1/2 of the range, stop the roller. Wait for the engine cooling down, and then fill oil in the hydraulic oil tank to the recommended mark.

If any problem appears, rotate the key to position OFF to stop the engine. Check out and eliminate the fault.

If everything is OK, rotate the throttle control switch to the MAX position to run the engine at rated speed.

4.6 Test Running

If all the checking items above are qualified for working, you can drive the roller to make some simple movements such as moving forward slowly, making a turning for testing. Before testing running, select the gear "tortoise".

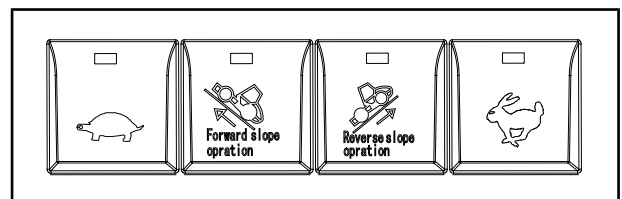

Fig 4-33

If there is any problem such as abnormal noise, vibration, smell, smoke, stop the engine and check faults out. If everything is OK, the roller can work.

4.7 Travel Operation

4.7.1 Travel Forward

Take the following steps to travel forward.

1. Select speed gear according to the road condition.

CAUTION

Risk of personal injury!
 Pushing or pulling the propel control lever without holding the steering wheel could lose direction control of the roller and could cause accidents.
 Holding the steering wheel while pushing or pulling the propel control lever.

2. Push the propel control lever forward from the neutral position.

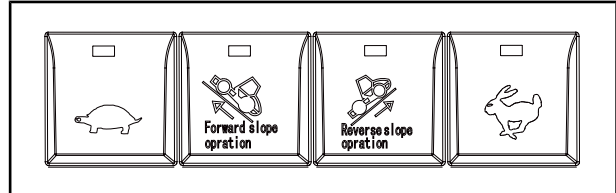

Fig 4-34

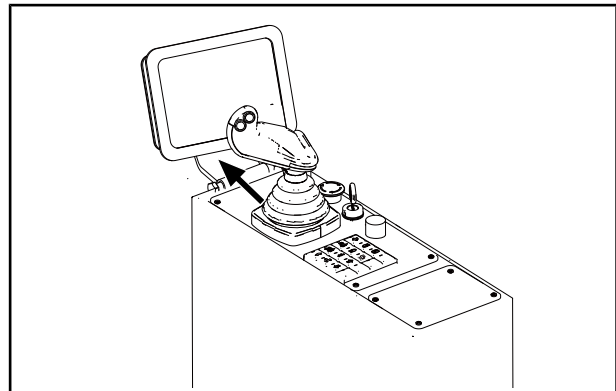



Fig 4-35

4.7.2 Travel Backward

1. Make the same settings as travel forward.

CAUTION

Risk of personal injury!
 Pushing or pulling the propel control lever without holding the steering wheel could lose direction control of the roller and could cause accidents.
 Holding the steering wheel while pushing or pulling the propel control lever.

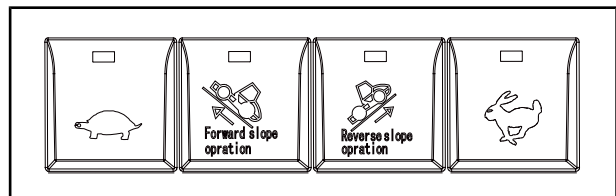

Fig 4-36

2. Then pull the propel control lever backward from the neutral position.

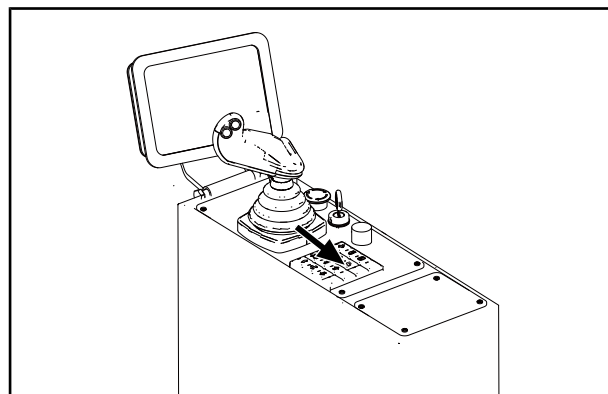

Fig 4-37

4.8 Vibration Operation

NOTE :

Only when the gear is at the gear 1/2/3, can the roller vibrate.

Take the following steps for roller to vibrate.

1. Choose gear 1/2/3.

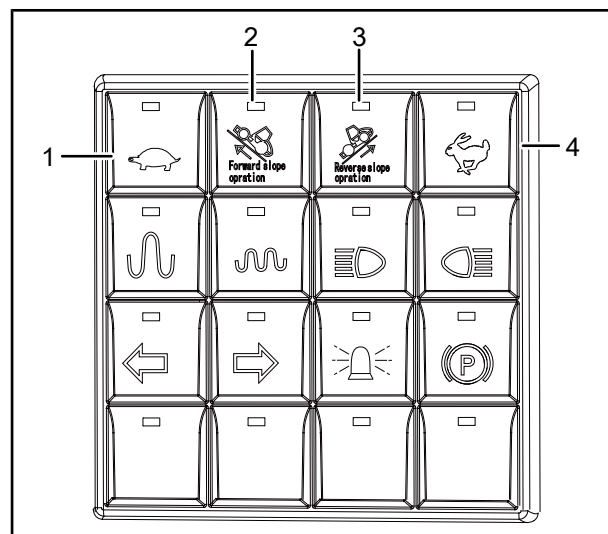

Fig 4-38

1. Gear 1

2. Gear 2

3. Gear 3

4. Gear 4

2. Choose vibration frequency according to the working requirements.

- High frequency with small amplitude and small compaction force.
- Low frequency with big amplitude and big compaction force.

Before switching the vibration mode, stop vibration first.

The single drum roller is often used to compact the foundations of the road. Different vibration frequency is chosen according to the working procedure. Generally, the working procedure could be static rolling, high-frequency rolling, low-frequency rolling and a final static rolling.

3. Push the propel control lever forward slowly to speed up the roller.

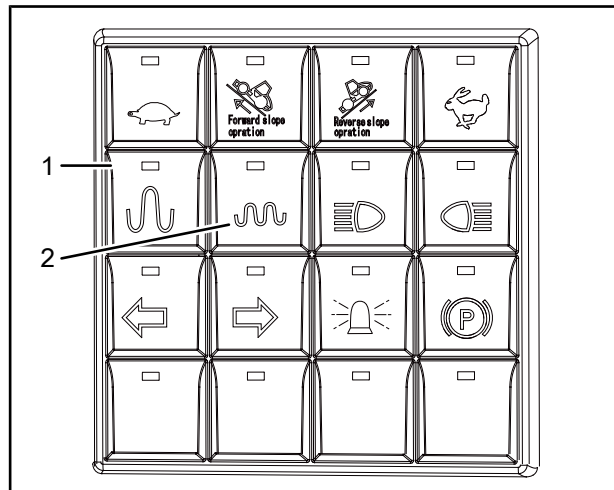

Fig 4-39

- 1. Low frequency, big amplitude
- 2. High frequency, small amplitude

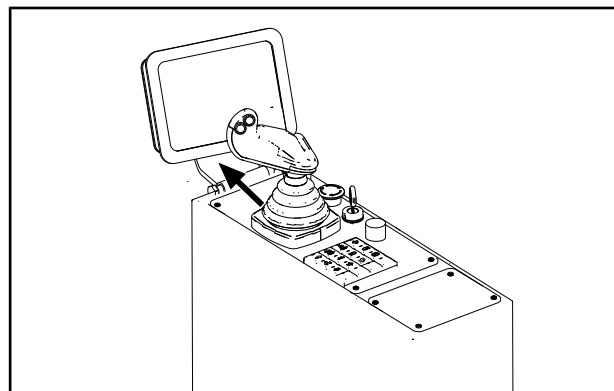

Fig 4-40

4. Press down the vibration button to vibrate.

NOTE :

The two vibration buttons are the same.

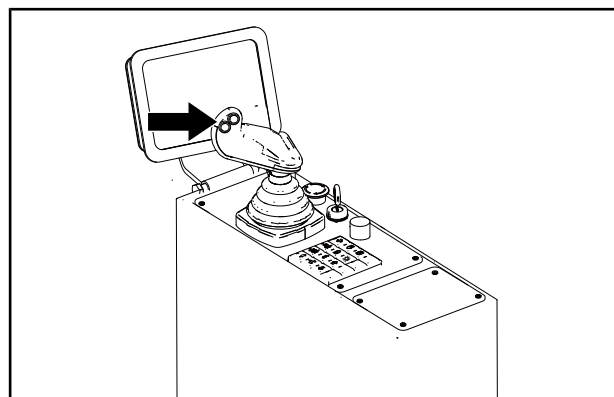

Fig 4-41

5. After work, press down the vibration button again to stop vibration.

NOTE :

The vibration total value to which the hand-arm system does not exceed 2.5 m/s^2 ; The highest root mean square value of weighted acceleration to which the whole body does not exceed 0.5 m/s^2 ; Uncertainty of measurement 0.1 m/s^2 .

4.9 Parking Operation

4.9.1 Service Brake

Service brake is used to stop the roller but not the engine. Service brake should be carried out before switching speed gears. Take the following steps to do service brake.

1. If the roller is vibrating, press down the vibration button to stop vibration.

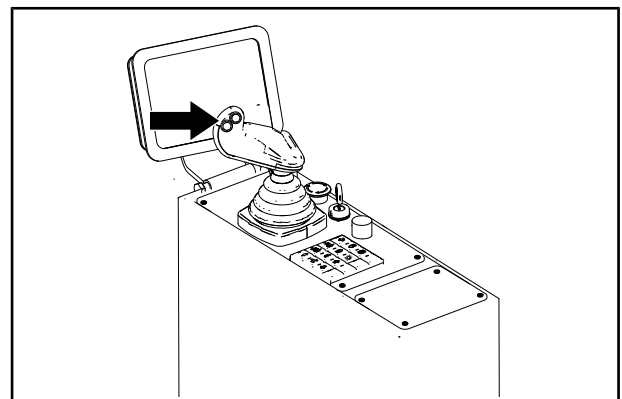

Fig 4-42

2. Move the propel control lever slowly to STOP position.

4.9.2 Park Brake

Park brake is used to stop the roller completely. Apply the park brake on a slope if the roller needs to be parked. After everyday's work, park brake will be carried out. Take the following steps to do park brake.

1. Select an applicable place for parking. Usually a flat ground is recommended.
2. Do service brake.

3. Press parking brake switch.

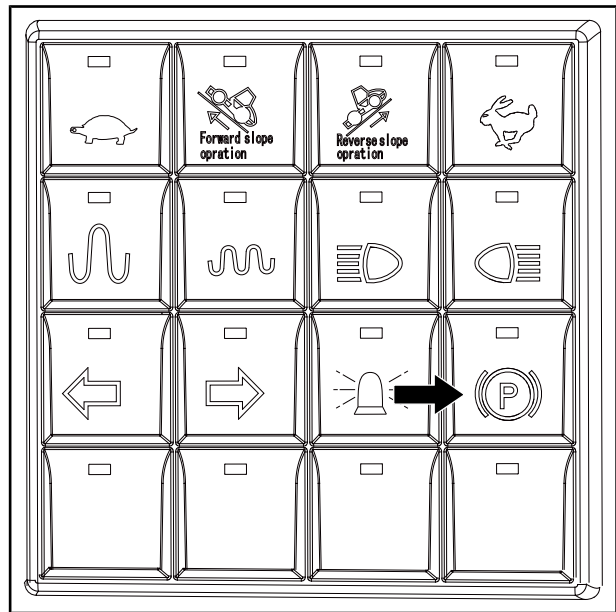

Fig 4-43

4. Turn the throttle control switch to the MIN position for engine's idle warm-up for 3 min - 5 min.

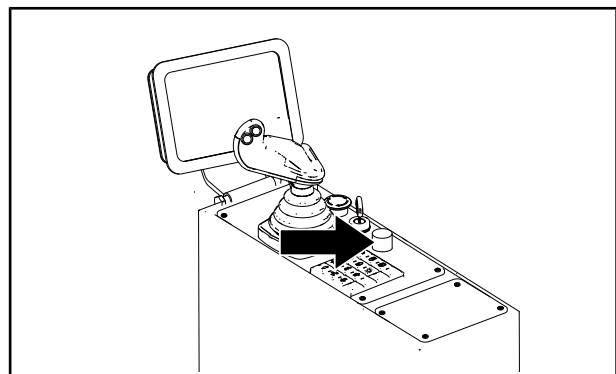

Fig 4-44

5. After 3 - 5 minutes' idle warm-up, rotate the key to position OFF, and remove the key.

6. Turn off the master disconnect switch of power supply. Lock the cabin's door.

4.9.3 Emergency Brake

NOTICE

Risk of machine damage!

The frequent use of the emergency stop switch could shorten the service life of the engine and other important parts.

Except for emergency, do not use emergency stop switch.

The emergency brake is used to stop the roller immediately, and the engine will be shut-down too. Press down the emergency stop switch at once when dangerous situation occurs.

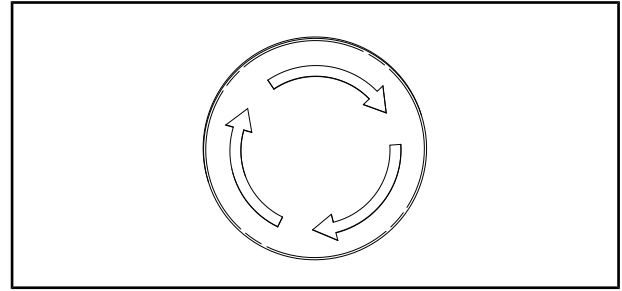

Fig 4-45

⚠ CAUTION

Risk of personal injury!
Restarting the roller under emergency could cause personal injury.
Eliminate the emergency, and then restart the roller.

NOTICE

Risk of machine damage!
Restarting the roller under emergency could cause personal injury.
Eliminate the emergency, and then restart the roller.

After pressing the emergency stop button, it is forbidden to start the engine. Rotate the button clockwise to relieve emergency brake.

4.10 Correct Driving According to the Road Condition

4.10.1 Working near Ditch Edge and Road Shoulder

When working near ditch edge, keep a safe distance to the edge. If necessary, reinforce it prior to work. When working near road shoulder, low speed gear is recommended. The operator should pay attention to the traveling direction to avoid destroying the road shoulder.

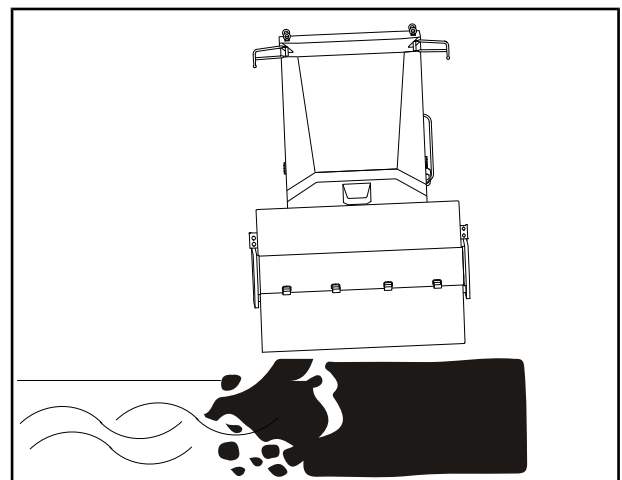

Fig 4-46

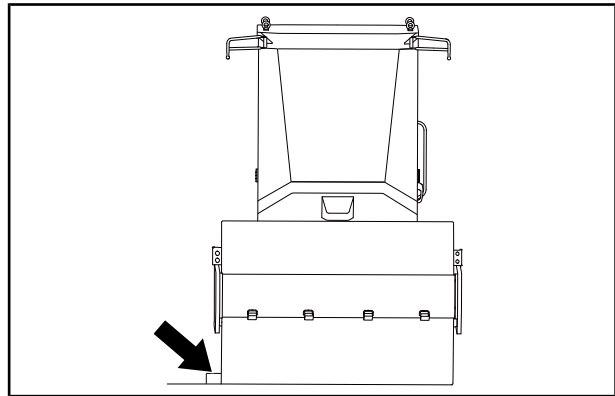

Fig 4-47

4.10.2 Working near Buildings Vulnerable to Vibration

When working near buildings such as over bridge and subway, generally the operator shouldn't start vibration as they might damage from vibration.

4.10.3 Working on the Slope

Before working on the slope, survey the gradient of the slope. When the value of gradient is beyond the roller's grade ability, the roller shouldn't be used to work.

While the gradient of the slope is in the range of the roller's grade ability, the operator can drive upward or downward in a straight line at low gear.

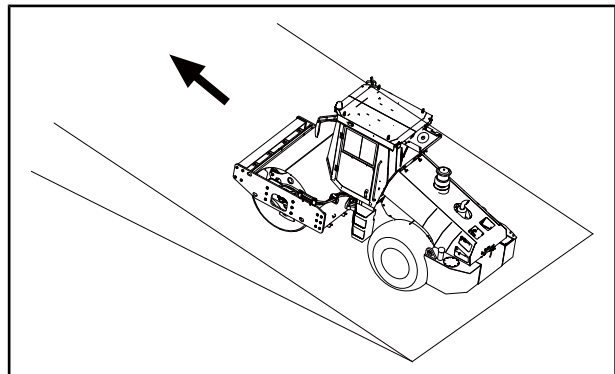

Fig 4-48

Vibration operation would increase the potential danger of slipping on the iced slope in winter.

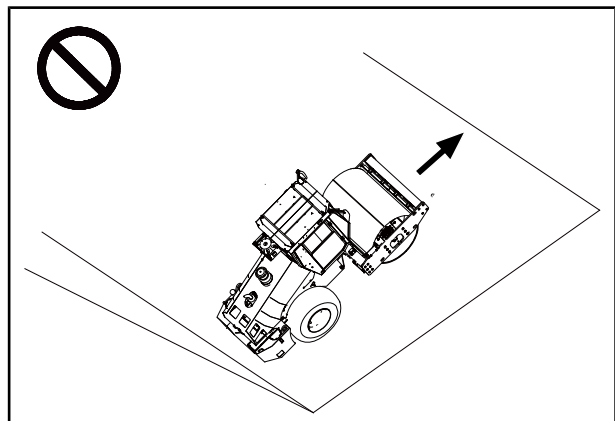

Fig 4-49

4.11 Check after Each Work Day

- Inspect your roller and check the work equipment of roller. Check for leaks of oil or coolant. Repair it in case of any problem.
- Refuel the fuel tank to maximum level.
- Check the engine compartment for any paper or other debris. Remove them, if any, in order to prevent fire.
- If the ambient temperature is below -35°C , make sure to drain the cooling water of radiator and engine (SANY uses the type of antifreeze liquid that freezes at -35°C).

4.12 Transportation

4.12.1 Transport Vehicle

- Whether road or railway transport is used to transport the roller, select vehicles with appropriate volume and loading capacity to transport the roller effectively. The vehicle must be qualified in maximum loading capacity, engine power, brake capability and others. It would be the best to exclusively transport the product without other machines each time.
- During transportation, take necessary measures to avoid sliding and rolling of the roller.
- Keep a certain distance when passing buildings, bridges, culverts, electric facilities, etc.
- Use the transport vehicle for long-distance machine transportation.

4.12.2 Using a Slope

1. Use slopes for the loading and unloading for heavy machines and ensure the slope is in the best status. Try to use a metal slope the one has been long laid aside and gone bad must not be used. The slope shall have sufficient width and strength to support the machine and a gradient less than 15%.

NOTE :

- Ensure the slope is placed between the transport vehicle and the ground correctly.
 - Ensure the slope is not covered with oil, snow, ice or mud.
 - Ensure foundations are laid for the transport vehicle.
2. Start the roller. Select the low gear. Adjust its position to make its front align with the slope. Drive it onto the transport vehicle slowly. Place sleepers (1) at the specified parking position on the transport vehicle in advance.

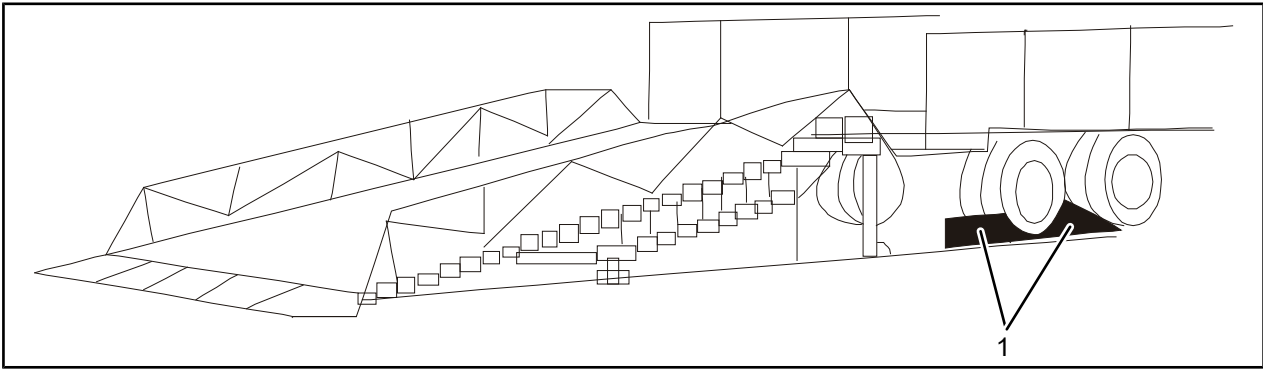

Fig 4-50

1. Sleepers

3. Fasten slings to fix the front and rear frames.

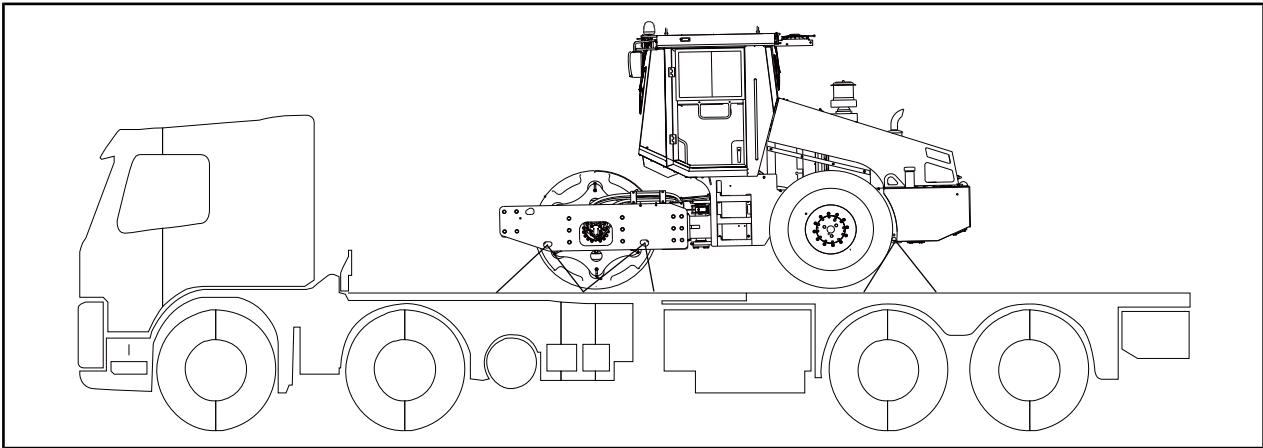

Fig 4-51

4.12.3 Shipping

Container shipping

1. Preparation

1) Removal of extra high and wide parts

- Disconnect the washer water pipe from the cabin. Fix the water pipe at the cab carrier.
- Disconnect the harnesses.
- Remove the cover on the mounting bracket of hood, and disconnect joints connecting the cab harness and the frame harness.
- Remove the interior trims in the cab (each at the left and right sides). Reinstall them after the cab is secured on the carrier.
- Remove the two side plates on the cab bottom (each at the left and right sides). Reinstall them after the cab is secured on the carrier.
- Remove the plates in the cab.
- Remove the connecting bolts between the cab and cab floor.

- Lift the cab and fix it onto the cabin carrier with bolts.

2) Protection of removed extra high and wide parts

Wrap up the removed interior trim clasp nails, floor screws, hood screws and cover plate with bubble film. Place them in the carton together with the rearview mirror package box. Then put the carton on the bottom plate of cabin.

3) Check before protection

Before protection, ensure the roller coating is qualified and has been dried completely. Ensure the surfaces are clean, dry and without any dust, water, oil or rust.

Ensure the fasteners connecting the roller parts have been treated against rust and are fixed at their original positions.

2. Protection process

Cleaning - rust-proof treatment to exposed non-coated parts - protection of engine - protective coating of complete machine - drying - partial protection - container loading.

1) Cleaning

- Use solvent gasoline or paint diluent to clean the exposed non-coated parts such as lamp shades, fasteners and tube connectors. Make sure: a. the cloth and paint brushes to be used are clean; b. the cleaned parts are clean and without any dust, rust or other foreign objects.
- After cleaning, dry them with compressed air or clean soft paper/car cleaning paper. Carry out protective treatment after 5 min -10 min.

2) Rust-proof treatment to exposed non-coated parts

- Apply anti-rust oil 377-HF evenly to the exposed plated parts and aluminum parts such as tube connectors, hydraulic valves, screws, and the coupling disc seat, primary filter support and secondary filter support of the diesel engine.
- Cover the oil cylinder piston rod in advance and remove the cover after applying protective coat. Use a piece of clean cloth dipped with diluent to clean these parts. After the solvent volatilizes, coat these parts with anti-rust oil 377-HF evenly.

3) Protection of engine

Apply protective coat AP1520 to the engine and the internal surfaces of hood for sealing in accordance with Article 5.5 in Q/SY 042 025-2008 Specification for the Protection of Exported Engineering Machinery.

4) Drying

Dry the coated complete machine.

5) Partial protection

Wrap up the control handle and control console with bubble film and tape. Then place silica-gel desiccant in the package.

3. Export container loading

1) Container loading of basic machine

Start the roller. Adjust the engine speed to 1500 rpm. Select gear 1. Adjust the roller position to be aligned with the container entrance. Drive the roller at a low speed into the container. Set a sleeper at the sill of the container for transition. Carefully observe the distances between the machine sides and the container to avoid the paint damage caused by interference. Stop driving when the front wheels contact with the limit sleeper. At last, shut down the machine and disconnect it from the power supply.

2) Fixing of basic machine

Park the roller at the center in the container. Set wedge blocks before/behind the drums and at the points of contact with container. Fix the wedge blocks with round steel nails. Connect the fixing hole on the machine with the hook in container by iron wires. This is to prevent roller bounce. Set wearable cloth in the fixing hole for protection.

3) Container loading and fixing of cabin

Use a forklift truck to load the cabin together with the cabin bracket into the container. Then fix them with.

4) Fixing of removed parts box

Seal the parts box containing the removed parts. Then put it on the platform at the left upper corner in the cabin.

5) Fixing of attached accessories box

Lift the wooden box containing the attached accessories to the middle under the cabin bracket with a forklift truck. Then, fix the bottom wood slats of the box to the container floor with steel nails.

6) Lifting of container with a reach stacker

Use a reach stacker to lift the container stably. Later, keep the reach stacker stationary and drive the flatcar to the place just under the container. Stably lower the container to the flatcar and fasten it.

7) Delivery

Carry out final check before Delivery. After getting out of the container, lock the container door.

4. Check the oil level and keys

Table 4-1 Oil Level Standard

No.	Item	Standard
1	Hydraulic oil	Between 1/2 ~ 2/3 of the level gauge scale
2	Lubricating oil	Between the marks Min and Max of the oil dipstick
3	Reducer gear oil	Just at the beginning of oil overflow from the overflow outlet
4	Diesel oil	1/8 at the electronic fuel gauge

Table 4-2 Key List

No.	Name	Qty	Unit	Remarks
1	Ignition key	2	Piece	
2	Cabin door key (left and right)	2	Piece	These 5 kinds of keys are interchangeable.
3	Fuel tank key			
4	Electric control cabinet key			
5	Battery box key			
6	Engine hood key			
Total		2	Piece	

Non-container shipping

1. Preparation

Before protection, make sure the roller coating is qualified and has been dried completely. Make sure the surfaces are clean, dry and without any dust, water, oil or rust.

Make sure the fasteners connecting the roller parts have been treated against rust and are fixed at their original positions.

2. Protection process

Cleaning - rust-proof treatment to exposed non-coated parts - protection of engine - protective coating of complete machine - drying - partial protection - handover at the port - shipping.

1) Cleaning

- Use solvent gasoline or paint diluent to clean the exposed non-coated parts such as lamp shades, fasteners, tube connectors, bolts and nuts. Make sure: a. the cloth and paint brushes to be used are clean; b. the cleaned parts are clean and without any dust, rust or other foreign objects.

- After cleaning, dry them with compressed air or clean soft paper/car cleaning paper. Carry out protective treatment after 5-10 minutes.
- 2) Rust-proof treatment to exposed non-coated parts
- Apply anti-rust oil 377-HF evenly to the exposed plated parts and aluminum parts such as tube connectors, hydraulic valves, screws, and the coupling disc seat, primary filter support and secondary filter support of the diesel engine. Then wrap them up with polyethylene film (or bags) against water.
- Cover the oil cylinder piston rod in advance and remove the cover after applying protective coat. Use a piece of clean cloth dipped with diluent to clean these parts. After the solvent volatilizes, coat these parts with anti-rust oil 377-HF evenly. Then wrap it up with cylinder sleeve. At last, fasten it with bandage.
- 3) Protection of engine
- Apply protective coat AP1520 to the engine and the internal surfaces of hood for sealing.
- 4) Protective coating of complete machine
- Apply protective wax AP585 to the following parts: cabin, front frame, rear frame, center articulation frame, hood, axles, hydraulic elements, tube connectors, plated parts, and spare parts without anti-rust oil and made of anticorrosive materials such as stainless steel, copper, nickel and chrome.
- 5) Drying
- Dry the coated complete machine.
- 6) Partial protection
- Wrap up the operation box with bubble film and tape. Place silica-gel desiccant in the package.
 - Seal the electrical connectors with tape against water. Protect parts of cabin connectors by the same means.
 - Wrap up the 4 lamps at the front and rear parts of cabin with polyethylene film.
 - Wrap up the products to be stepped on with bubble film and tape.
 - Wrap up the cylinder axis pin with sleeve. Fix the related parts with hose clamps.

3. Handover at the port

Carry out inspection after the goods arrive at the port and before shipping. Accept the goods only after the following conditions are met.

- The overall paint is undamaged.
- The seals for the rearview mirror carton, attached accessories box and document box are intact and undamaged.
- The cabin doors and windows and the hood are closed and locked.
- The articulation fixing rod is locked.

4. Shipping

1) Equipment shipping

- General cargo ship

Carry out lifting according to the lifting nameplate. Wrap the steel rope at the lifting eye with wearable cloth to protect the paint there. Lift and lower the roller slowly to protect its structure against damage.

- Roll-on-roll-off ship

For roll-on-roll-off ships, a platform or slope shall be used to connect the ship and wharf. The gradient of the platform or slope shall not exceed 35°. This is to avoid steering when driving up/down the slope. If steering is required, drive the machine back to the ground. After correcting the direction, drive it onto the slope.

2) Equipment fixing

Fix the roller with solid pull rods. Wedge the front and rear drums with triangle timber blocks. Take other measures to fix the machine firmly. In addition, drain the engine water tank. Reserve some fuel for dispatch. Disconnect the circuit between the battery and the frame.

5. Check the oil level and keys

For detailed information, **see** [Table 4-1](#).

Complete the key handover procedures. **See** [Table 4-2](#).

4.12.4 Towing Information

NOTE :

Only the machine with the park brake release device can be towed.

Park brake release procedure (If equipped)

WARNING

Rear wheels and drum should be blocked when performing park brake release procedure to prevent unexpected movement of the machine. Failure to comply could result in death or serious injury.

1. Block rear wheels and drum to prevent machine movement. Do not remove blocks until the tow bar is secure to the machine and the towing vehicle.
2. Open hood and locate the park brake release valve (3).

3. Push manual release valve (2) into the park brake release valve (3) until it is seated in the pushed in position.

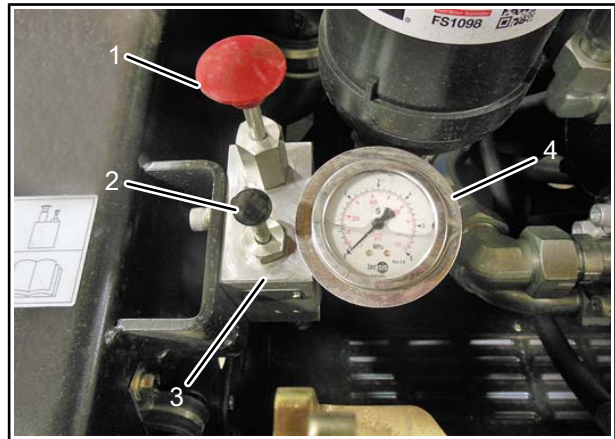

Fig 4-52 Park Brake Release Valve

- | | |
|-------------------------|-----------------------------|
| 1. Manual pump plunger | 3. Park brake release valve |
| 2. Manual release valve | 4. Pressure gauge |

4. Push and pull the manual pump plunger (1) while observing the pressure gauge. Pump until pressure gauge reaches specification to release park brakes.

Specification

Park Brake Release	
Minimum Pressure	1.5 MPa
Park Brake Release	
Maximum Pressure	2 MPa

5. When the engine is not running, there are additional steps that are required before towing the machine. See above content for more information.

6. Slowly tow the machine to the desired location.

7. When at desired location, block the rear wheels and drum.

8. Pull manual release valve (2) up from the park brake release valve (3) until it is seated in the pulled up position to engage the park brake.

Towing safety rules

⚠ WARNING

- Do not use chains, cables, or rope to pull the machine. If the chain, cable, or rope breaks or slips, it may whip with sufficient force. Only use rigid draw bars or tow bars to tow the machine.
- Attempting to free a stuck machine can involve safety hazards such as the stuck machine and towing vehicle tipping or overturning and/or the tow bar failing. Always use proper towing equipment.

Failure to comply could result in death or serious injury.

To free a stuck machine:

- Always attempt to back the machine out if it gets stuck.
- Unhitch any towed implements or equipment.
- Clear mud from behind the rear wheels. Back the machine out slowly.

If it becomes necessary to pull with another machine:

- Use a tow bar hitched to the towing point of the towing vehicle.
- Make sure that the towing devices are of adequate size and strength.
- Before moving or attempting to pull, always make sure the area is clear of others. When you are certain that it is safe to do so, drive slowly and smoothly.

Towing points

⚠ WARNING

- Do not use chains, cables, or rope to pull the machine. If the chain, cable, or rope breaks or slips, it may whip with sufficient force. Only use rigid draw bars or tow bars to tow the machine.
- Attempting to free a stuck machine can involve safety hazards such as the stuck machine and the towing vehicle tipping or overturning and/or the tow bar failing. Always use proper towing equipment.

Failure to comply could result in death or serious injury.

If the machine is stuck and unable to get out under its own power, use adequate towing devices to assist in its remove through the towing position shown in the right figure. Max. towing force: 30kN.

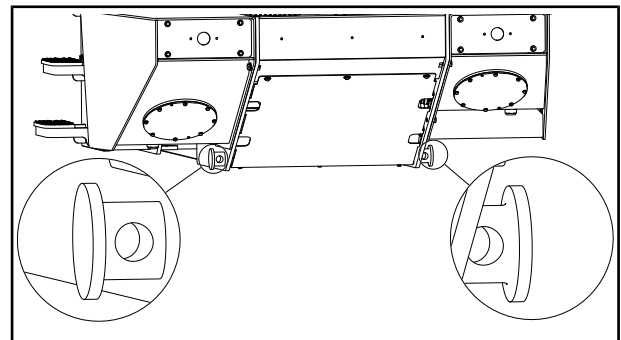

Fig 4-53

Towing the machine

These towing instructions are for moving a disabled machine for a short distance at low speed to a convenient location for repair. These procedures are only for emergencies. Always transport the machine if long travel distance is required.

WARNING

Because of hydraulic oil pressure requirements, special rules apply when the machine engine is running or not running. Use the correct procedure for the condition.

NOTE :

The machine is equipped with a spring applied, hydraulically released park brake. The park brake has a special release procedure when the engine is not running. Review the procedure before attempting to tow the machine.

When towing the machine:

- Make sure all controls are in the correct position.
- Use a rigid tow bar to pull the machine using the correct towing points.
- Attach towing devices to machine before releasing the park brake.

Engine Running Tow Procedure

NOTICE

When the engine is running, the steering and park brake system must be operable to prevent damage to the systems.

1. Block the rear wheels and drum to prevent machine movement. Do not remove blocks until the tow bar is secure to the machine and the towing vehicle.
2. Attach tow bar to the machine.
3. Place the travel control lever to the neutral position.
4. Start the engine and turn the park brake switch to release the park brake.
5. Remove blocks from machine.
6. Slowly tow the machine and steer to the desired location.
7. When at desired location, turn the park brake switch to engage the park brake. Block the rear wheels and drum.
8. Stop engine and remove tow bar.

9. Follow proper lockout and tagout procedure. See “Lockout/Tagout Procedures” on page 2-38.

Engine Not Running Tow Procedure

NOTICE

When the engine will not start, the result will be loss of machine steering and park brake will be applied.

Additional steps may be required before the machine is towed in order to avoid damaging the brakes, steering, and power train systems.

1. Block rear wheels and drum to prevent machine movement. Do not remove blocks until the tow bar is secure to the machine and the towing vehicle.
2. Attach tow bar to the machine.
3. Place the travel control lever in the neutral position.
4. Install frame locking bar.



Fig 4-54

5. Disconnect steering cylinders (2) from front carriage and secure to the main frame.

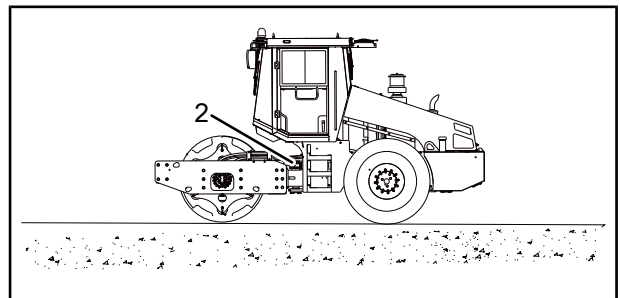

Fig 4-55

2. Steering cylinders

6. Manually release park brake.
7. Remove frame locking bar and blocks.
8. Slowly tow the machine to the desired location.

9. Install frame locking bar and block drum and wheels.
10. Manually engage park brake. see the content below for the detail procedures.
11. Connect steering cylinders to the front carriage.
12. Follow proper lockout and tagout procedure. See [“Lockout/Tagout Procedures” on page 2-38](#).

SANY

Maintenance

5 Maintenance	5-1
5.1 Maintenance Information	5-3
5.1.1 Introduction	5-3
5.1.2 Checks before Maintenance.....	5-3
5.1.3 Checks after Maintenance or Repairs.....	5-3
5.1.4 Notes on Maintenance	5-4
5.1.5 Notes on Fuel System	5-4
5.1.6 Notes on Engine Performance	5-5
5.1.7 Notes on Hydraulic System	5-5
5.1.8 Torque Values	5-5
5.2 Requirements on Use of Oil & Fluid	5-7
5.2.1 Introduction of Functional Oil & Fluids	5-7
5.2.2 Oil & Fluids Selection	5-9
5.2.3 Filling Capacities	5-14
5.3 Test Run Instructions	5-15
5.4 Maintenance Schedules.....	5-16
5.4.1 Introduction	5-16
5.4.2 Roller Maintenance Locations.....	5-16
5.4.3 Routine Maintenance.....	5-17
5.4.4 Engine–Store	5-18
5.4.5 Short-time Storage–Maintain	5-19
5.4.6 Long-time Storage–Maintain	5-19
5.4.7 Post-maintenance Roller–Check.....	5-19
5.4.8 Regular Technical Maintenance Intervals	5-20
5.5 Maintenance for the Power System	5-22
5.5.1 Air Filter–Clean/Replace	5-22
5.5.2 Engine Oil–Check/Refill/Change	5-26
5.5.3 Engine Oil Filter Element–Replace	5-29
5.5.4 Oil Water Separator–Check/Drain/Replace	5-29

5.5.5 Radiator–Check/Clean	5-33
5.5.6 Engine Coolant-Check/Change	5-34
5.5.7 Engine Belt–Check/Replace.....	5-36
5.5.8 Engine Air Intake Pipeline–Check	5-36
5.5.9 Fuel-Check/Refill/Replace	5-37
5.5.10 Fuel Filter–Replace	5-39
5.5.11 Crankcase Vent Line–Check	5-40
5.5.12 Aftertreatment System - Check/Fill	5-40
5.6 Maintenance for the Hydraulic System	5-41
5.6.1 Hydraulic Oil-Check/Refill/Change	5-41
5.6.2 Hydraulic Oil Filter–Replace	5-44
5.7 Maintenance for the A/C	5-45
5.7.1 A/C-Check/Maintain.....	5-45
5.7.2 Compressor V-belt–Check/Replace	5-48
5.8 Maintenance for the Electric System.....	5-49
5.8.1 Battery–Maintain	5-49
5.8.2 Electric Box-Maintain.....	5-51
5.8.3 Fuse-Replace	5-52
5.9 Maintenance for the Mechanical System.....	5-53
5.9.1 Grease for Propel Bearing-Fill.....	5-53
5.9.2 Grease for Central Articulation Frame-Fill.....	5-54
5.9.3 Lubricant for Drum Vibration Bearing-Replace.....	5-54
5.9.4 Lubricant for Reducer-Replace	5-55
5.9.5 Lubricant for Rear Axle-Replace.....	5-56
5.9.6 Damper-Check/Replace.....	5-57
5.9.7 Windshield Washer Fluid–Check/Fill.....	5-57
5.9.8 Oil tank and Pipes–Check.....	5-58

5.Maintenance

5.1 Maintenance Information

5.1.1 Introduction

Do not perform any maintenance and/or repairs not authorized in this Safety, Operation & Maintenance Manual or the Shop Manual for this machine. Always observe and follow all safety precautions and use the proper tools when performing any maintenance procedures.

5.1.2 Checks before Maintenance

Observe and understand these points to ensure your safety:

- Read and understand the Safety section of this manual — including the Lockout/Tagout procedure — before proceeding with any inspection or maintenance procedures. See [“Lockout/Tagout Procedures” on page 2-38](#).
- Do not perform any maintenance not authorized in this operator’s manual maintenance section for this machine. If unauthorized maintenance on this machine must be done, contact your SANY distributor before proceeding.
- Avoid working on the machine while the engine is running unless required to do so in the procedure. If the engine must remain running during a procedure, always have a person in the cabin who can correctly operate the machine and who is in clear contact with you at all times.
- Contact your SANY distributor if you are unable to perform the procedures listed in this manual or if additional procedures are required.
- Always use the proper tools when performing any maintenance procedures.
- Obtain the maintenance record for this machine before proceeding with any repair work.
- Always use the maintenance record for this machine to keep a daily record of the hour meter reading, then refer to it when determining your schedule of maintenance procedures.
- Always use genuine SANY parts, coolants and lubricants when maintaining this machine. Failure to do so may result in premature system or component failure.
- Always use clean “EP” (extreme pressure) grease when lubricating the machine. Avoid using low viscosity greases.
- If any access covers must be open when working on this machine, be sure those covers are properly supported.

5.1.3 Checks after Maintenance or Repairs

Always do the following after performing any maintenance to the machine.

With the machine running:

- Check for any leakage in the system you have serviced.

- Be sure there are no abnormal sounds coming from the engine or hydraulic system.
- Check for any loose or abnormal movement in the system you have repaired.
- Check for any overheating of the system you have serviced.

With the engine off:

- Be sure you have completed all the steps in the maintenance or repair of the machine.
- If necessary, have a coworker inspect your work for correct and proper completion.
- Be sure the covers are reinstalled, close tightly and latch securely in place after completion of maintenance. Be sure that any locks are properly latched for security.
- Always inventory your tools, parts used and nuts and bolts after completing maintenance to ensure that none of these items were left on or inside the machine. Failure to do so could result in unexpected failure or damage to the machine.
- If any hydraulic components have been replaced or removed, always bleed the air from the system before resuming and work operations. Be sure there are no leaks and the hydraulic hoses or fuel lines are not twisted and do not rub on any other components.
- Complete the maintenance record for this machine and return it to its permanent storage location.
- Follow the Lockout/Tagout procedure for returning the unit to service. **See** [“Lockout/Tagout Procedures” on page 2-38.](#)

5.1.4 Notes on Maintenance

Read all applicable safety instructions when you service the roller.

The reliability of roller will be increased and the lifetime of essential components will be prolonged with thorough machinemaintenance. The faults result from not observing the safety instructions will cause more effort than maintenance work.

During maintenance, you should:

- Completely clean the roller and engine before maintenance.
- Park the roller on level ground for maintenance.
- When carrying out maintenance work, shut down the engine.
- Depressurize the hydraulic lines before working on them.
- Cut off the battery power supply before working on the electrical parts.
- Collect the effluent lubricant, coolant and fuel to prevent contamination.

5.1.5 Notes on Fuel System

The service life of diesel engine mainly depends on the fuel purity. During maintenance, you should:

- Make sure the engine is free of dirt and water otherwise the fuel injection parts on the engine might damage.
- Never use a galvanized iron barrel to store fuel.

- Before drawing the fuel out from a barrel, store the barrel for a long time.
- Prevent the fuel suction pipe from churning the fuel barrel.
- Never draw the fuel out on the bottom of the barrel.
- The fuel left at the bottom of the barrel can't be used by engine. It is used for cleaning.

5.1.6 Notes on Engine Performance

The rate between combustion air and fuel injection of the diesel engine has been carefully adjusted. Engine's performance, temperature level and the quality of the exhaust gas are determined by that.

You should consult the service department of our company or engine manufacturer if the machine has to work with full load in the thin air (at high altitude).

5.1.7 Notes on Hydraulic System

Keep the hydraulic system clean to avoid contamination. Make sure no dirt or any other dirty substance enters the system, as even tiny particles may scratch the valve, make pumps to seize or block the throttle or guide hole, resulting in high repair cost.

- If the oil level is found to have dropped during the daily check, check all lines and hydraulic components for possible leakage.
- Seal the external leakage at once. If necessary, inform the relevant after-sales service department for repair.
- Never leave the barrel containing hydraulic oil in the open air. The water may enter the barrel through the oil outlet because of weather changes.
- Use oil filling and filtering devices to refill hydraulic oil. This device is equipped with a filter that can filter the hydraulic oil and prolong the lifetime of the filter.
- Before removing the connector and oil tank cover, clean them and the surfaces around to prevent dirt from entering the system.
- Unless it is necessary, do not leave the oil filler of the hydraulic oil tank open. Otherwise, the dirt may enter the oil tank.

5.1.8 Torque Values

NOTICE

Nuts, bolts or other parts not tightened to specific torque values may lead to loose or damaged parts. This situation can cause damage to the machine, personal property, or cause the machine to operate improperly.

Unless otherwise specified, a torque wrench is used to tighten nuts and bolts to the torque values listed below.

Table 5-1 Tightening torques for bolts and nuts

No.	Thread size	Strength level (6.8)	Strength level (8.8)	Strength level (10.9)	Strength level (12.9)
		Tightening torque (N·m)	Tightening torque (N·m)	Tightening torque (N·m)	Tightening torque (N·m)
1	M5	5±0.5	6±0.6	9±1	11±1
2	M6	8±1	10±1	16±2	19±2
3	M8	20±2	23±2	35±4	45±5
4	M10	40±4	45±5	75±8	90±9
5	M12	68±7	85±9	118±12	154±15
6	M14	110±11	145±15	204±20	244±24
7	M16	164±16	210±20	290±29	369±37
8	M18	229±23	300±30	428±43	514±51
9	M20	320±32	408±40	600±60	720±72
10	M22	429±43	573±57	805±80	966±96
11	M24	552±55	710±71	1040±105	1243±124
12	M27	809±81	1078±108	1516±150	1820±182
13	M30	1106±110	1474±147	2073±207	2488±249
14	M33	1488±150	1984±198	2790±279	3350±335
15	M36	1942±190	2590±259	3167±317	4368±437

NOTICE

- Apply lubricant (that is, Zinc White B in spindle oil) to nuts and bolts to reduce their coefficient of friction. Thrust bolts do not require lubricant.
- The torque tolerance is ±10%.
- Be sure to use the bolts with correct lengths. If the bolt is too long, it cannot be tightened because the top of the bolt touches the bottom of the bolt hole. If the bolt is too short, the tightening force will be insufficient.
- The torque values given in the table are for general use only. Do not use the torques in this table if different torques have been given for special occasions.
- Before installing nuts and bolts, make sure that their threads are clean. Remove dirt or rust if any.

5.2 Requirements on Use of Oil & Fluid

5.2.1 Introduction of Functional Oil & Fluids

Engine oil

Choose engine oil according to the function and type. Other engine oil meeting the required specifications also can be chosen.

As the viscosity of engine oil varies with the temperature, the local ambient temperature is extremely important for the selection of viscosity grade.

If the ambient temperature is occasionally lower than the applicable temperature limit (for example, using SAE 15W/40 engine oil at -15°C), only the engine cold start capability will be affected but not the engine capability.

The multi-grade oil does not require frequent oil change according to the temperature change. The synthetic oil is better since it can be used under higher temperature and it is more reliable.

The maximum allowable duration for the engine oil is 1 year. If the oil change intervals exceed 1 year, the oil shall be changed at least once a year.

The engine oil used by this machine shall be changed every 250 working hours. This change interval is only applicable for engine adopting diesel oil with sulfur content below 0.5% and in temperature above -10°C .

When the sulfur content is 0.5%~1% or the temperature is below -10°C , the oil change interval should be shortened half. If the sulfur content is 1% - 1.5%, the engine oil shall contain TBN, 12 times more sulfur content, with the change interval shortened half.

Fuel

WARNING

Risk of death or personal injury!

Explosion could be caused if diesel is mixed with gasoline or alcohol, which could cause death or personal injury.

Do not mix diesel with gasoline, alcohol or mixture of gasoline and alcohol.

NOTICE

Risk of machine damage!

The water and impurities in the fuel system could cause serious damage to engine pump and nozzle.

Fuel quality should be controlled strictly.

Regular diesel oil meeting national and local emission standard is recommended.

The diesel oils below are permitted:

- GB252
- DINEN590
- BS 2869: A1 and A2
- ASTM D 975-78: 1-D and 2-D
- NATO Code F-54 and F-75

Refill the tank to avoid running out of oil. Otherwise, the lube filter and injection lines need to discharge.

Only commercially available diesel fuel can be used. Ensure that the sulfur content is less than 0.5% and no contamination when filling in. Higher sulfur content has negative effect on oil change intervals.

To avoid blocking caused by paraffin, only winter diesel fuel can be used in temperature below 5 °C . The mixture of diesel oil and proper additive can also be used.

Lubricant

Lubricant includes engine oil, gear oil, transmission oil, hydraulic oil, etc.

The proper viscosity grade is determined not only by the minimum outside temperature when the machine is started, but also by the maximum outside temperature while the machine is operated.

Parts that are continuously operated should use the oil with higher viscosity in order to maintain the highest possible oil film thickness.

Grease

Use lithium-based high pressured saponified grease.

Coolant

Antifreeze of organic acid technology (OAT) is adopted.

NOTE :

- Do not mix coolant with additives of different types.
- The protective agent of cooling system must be disposed environmentally.

Diesel Exhaust Fluid (DEF)

SANY recommends using diesel exhaust fluid (DEF) that meets ISO 22241-1 standards.

5.2.2 Oil & Fluids Selection

NOTICE

Risk of machine damage!

Failing to use the oil and fluid according to this manual could affect the machine performance and cause damage to relevant parts.

Do follow the manual while using the oil and fluids.

NOTICE

Risk of machine damage!

Mixed use of different brands of oil could cause machine performance degradation or component failure.

Never mix oil and fluids of different brands while using them.

- SANY special oil and fluids are recommended.
- Select oil and fluids with proper quality grade, technical specifications and viscosity as per latest standard of related authorities according to this manual.
- Disposal of oil and fluids should comply with local laws and regulations.
- Viscosity selection:

1) Ambient temperature

Check the ambient temperature before the machine starts. Choose proper viscosity of oils and fluids under such temperature according to the standards.

NOTE :

In extreme cold area, use parts heating system and apply oil and fluids of higher viscosity grade.

2) Viscosity grade

Proper viscosity depends on the minimum ambient temperature, which is the temperature for machine startup and operation.

To determine proper viscosity grade under the maximum ambient temperature for startup and operation, refer to the "Max. Temp." in the following tables. Unless specially specified, the maximum allowable viscosity grade under ambient temperature should be selected for machine startup. For long-term operation, oil and fluids of higher viscosity should be selected for transmission and differential, so as to maintain the thickest film.

- Oil and fluids used under low temperature:

1) Before startup of the machine, ensure engine oil, transmission oil, hydraulic oil and other fluids are full. Take out the dipstick, check that the oil or fluid flows down the dipstick easily. Oil or fluid diluted by kerosene is prohibited.

2) If different oil or fluid is replaced under low temperature, the filter element should be replaced too. Otherwise, the filter element and housing will be solidified. Drain the oil and fluids in hydraulic cylinder and pipelines. After replacement, run the machine to circulate the oil and fluid.

3) Select proper viscosity according to this manual.

4) In case of change of temperature, change proper oil and fluids according to this manual.

Requirements of oil and fluids.

Table 5-2 Engine Oil Under Different Ambient Temperature

Part/ System	Type, quality grade & technical spec. of oil & fluids	Viscosity grade of oil & fluids	Ambient temp. (°C)	
			Min. Temp	Max. Temp.
Engine crankcase	Diesel Engine Oil • API CI-4 • GB 11122	SAE 0W-20	-40	10
		SAE 0W-30	-40	30
		SAE 0W-40	-40	40
		SAE 5W-30	-30	30
		SAE 5W-40	-30	40
		SAE 10W-30	-20	40
		SAE 10W-40	-20	50
Note	<ul style="list-style-type: none"> • Proper fluid types should be selected according to different environment temperature . • For engine with emission of China II or Euro II standard for off-road machine, API CH-4 or lubricant of higher grade should be used. • For engine with emission of China III or Euro III standard for off-road machine, API CH-4 or lubricant of higher grade should be used. • For engine with emission of Euro IV standard for off-road machine, API CJ-4 or lubricant of higher grade should be used. 			

Table 5-3 Gear Oil Under Different Ambient Temperature

Part/System	Type, quality grade & technical spec. of oil & fluids	Viscosity grade of oil & fluids	Ambient temp. (°C)	
			Min. Temp	Max. Temp.
Transfer case/Reducer	Industrial Enclosed Gear Oil (mineral oil). • DIN 51517 Part 3-group CLP • ISO 12925-1 CKD • AIST 224 • AGMA 9005-E02:EP • GB 5903	150	-10	40
		220	-5	50
	Industrial Enclosed Gear Oil (PAO). • DIN 51517 Part 3=>group CLP • NF-ISO 6743-6 Category CKD • AIST 224 • AGMA 9005-E02 • GB 5903	150	-40	50
		220	-40	50
Note	Proper fluid types should be selected according to different environment temperature.			

Table 5-4 Automotive Gear Oil Under Different Ambient Temperature

Part/System	Type, quality grade & technical spec. of oil & fluids	Viscosity grade of oil & fluids	Ambient temp. (°C)	
			Min. Temp	Max. Temp.
Rear axle	Heavy-duty Automotive Gear Oil • API GL-5 • GB 13895	SAE 75W-90	-40	30
		SAE 80W-90	-20	40
		SAE 85W-90	-15	40
		SAE 85W-140	-10	50
		SAE 90	0	40
Note	Proper fluid types should be selected according to different environment temperature.			

Table 5-5 Hydraulic Oil Under Different Ambient Temperature

Part/System	Type, quality grade & technical spec. of oil & fluids	Viscosity grade of oil & fluids	Ambient temp. (°C)		
			Min. Temp	Max. Temp.	
Hydraulic system	Normal Temperature Hydraulic Oil HM / L-HM Anti-wear Hydraulic Oil <ul style="list-style-type: none"> • AFNOR NF E 48-603HM • ISO 11158 L-HM • CINCINNATI P68、 P69、 P70 • EATON-VICKERS M-2950 S、 I-286 S • PARKER-DENISON HF-0、 HF-1、 HF-2 • Q/SH303 0550 • GB 11118.1 	32	-20	5	
		46	-20	10	
		68	-15	50	
	Wide-temperature Hydraulic Oil HV / L-HV Low-temperature Hydraulic Oil <ul style="list-style-type: none"> • AFNOR NF E-48-603 HV • ISO 67434/4 HV • DIN 51524 P3 HVLP • CINCINNATI P68、 P69、 P70 • EATON(VICKERS) M-2950S、 I-286 S • Q/SH303 0661 • GB 11118.1 	32	-30	10	
		46	-30	15	
		68	-25	50	
	Aircraft hydraulic oil <ul style="list-style-type: none"> • SH 0358 • Q/SH PRD0476 	10#	-40	5	
	Note	Proper fluid types should be selected according to different environment temperature.			

Table 5-6 Grease Under Different Ambient Temperature

Part/System	Type, quality grade & technical spec. of oil & fluids	Speed with load	NLGI grade	Ambient temp. (°C)	
				Min. Temp	Max. Temp.
Motor spline	EP Lithium-based Lubricating Grease • ISO 6743-9: L-XBCEB2 • DIN 51502: MPF2K-25 • SH/T 0587	/	2	-25	50
	EP Lithium-based Lubricating Grease • ISO 6743-9: L-XBCEB 2 • DIN 51502: MPF3K-20 • SH/T 0587		3	-20	50
Travelling bearings/ articulated frame	EP Lithium-based Lubricating Grease • ISO 6743-9: L-XBCEB 1 • DIN 51502: KP1K-30	High	1	-30	40
		High	2	-25	50
	EP Lithium-based Lubricating Grease • ISO 6743-9: L-XBCEB 2 • DIN 51502: KP2K-25 • GB/T 7323	Mid	2	-20	40
		Low	2	-25	40
	Tank Lithium-based Lubricating Grease GJB 4364	/	2	-50	50
Note	<p>Unless specially specified, this machine adopts the following fluids:</p> <ul style="list-style-type: none"> • Motor spline: EP Lithium-based Lubricating Grease 3# With Molybdenum Disulfide It is specially used for SANY machine with applicable temperature of -20°C to 50°C. • Centralized lubricating device and guide device: Extreme Pressure Lithium-based Lubricating Grease 2#. It is specially used for SANY machine with applicable temperature of -25°C to 50°C. 				

Table 5-7 Coolant Under Different Ambient Temperature

Part/System	Type, quality grade & technical spec. of oil & fluids	Viscosity grade of oil & fluids	Ambient temp. (°C)	
			Min. Temp	Max. Temp.
Cooling system (Engine radiator)	Antifreeze • OAT • GB 29743	-35	-30	50
		-45	-40	50
Note	Proper fluid types should be selected according to different environment temperature.			

Table 5-8 Diesel Oil Under Different Ambient Temperature

Part/System	Type, quality grade & technical spec. of oil & fluids	Grade of oil (as per condensation point)	Ambient temp. (°C)	
			Min. Temp	Max. Temp.
Fuel system (Diesel engine)	Regular diesel oil GB 252	Diesel Oil 5#	8	50
		Diesel Oil 0#	4	50
		Diesel Oil -10#	-5	50
		Diesel Oil -20#	-14	50
		Diesel Oil -35#	-29	50
		Diesel Oil -50#	-44	50
Note	<ul style="list-style-type: none"> • Unless specially specified, this machine adopts Diesel Oil 0# when delivery. • Regular diesel oil meeting national and local emission standard is recommended. 			

5.2.3 Filling Capacities

Table 5-9 Oil & Fluids Filling Capacities

Part/System	Type, quality grade & technical spec. of oil & fluids	Dosage
DEF tank	DEF must meet ISO 22241-1	At least 10 L each time
Fuel tank	#2 Diesel fuel	about 220 L
Reducer	Industrial enclosed gear oil L-CKD 220	about 6 L
Diesel engine crankcase	Diesel engine oil CJ-4 10W-40	about 10 L

Table 5-9 Oil & Fluids Filling Capacities (continue)

Part/System	Type, quality grade & technical spec. of oil & fluids	Dosage
Vibratory drum	Diesel engine oil CJ-4 15W-40	about 10 L
Rear axle	Heavy-duty gear oil 85W-140	about 20 L
Travelling bearings	EP lithium-based lubricating grease NLGI 2	about 3.4 L
Hydraulic oil tank	HV 46	about 80 L
Water tank of diesel engine	Antifreeze OAT -45	about 39.7 L
Air conditioning	R134a	1 kg
Note	<ul style="list-style-type: none"> • Without special requirements, above fluids are used for this equipment. • Proper fluid types should be selected according to different environment temperature. 	

NOTE :

The emission of 1 kg R134a into the atmosphere is equivalent to the greenhouse effect of 1.3 t of carbon dioxide into the atmosphere.

5.3 Test Run Instructions

The maintenance below must be applied for the new machine or overhauled engine.

Check the engine oil level twice a day after every 250 working hours.

According to the load, the engine oil consumption become normal after running for 100-250 h.

After running for 250 h, you should do as follows:

- Check the engine for leaks.
- Tighten bolts on the intake/exhaust pipes, oil sump and engine base.
- Tighten the screws on the machine.
- Change the oil for drum vibration bearing.
- Change the engine oil. Change the engine oil filter.
- Change engine fuel filter and fuel-water separator filter element.

After running for 500 h, you should do as follows:

- Change the oil for drum vibrating bearing.
- Change main element and safety element of air filter .
- Add lubricant for propel bearing and center articulation frame.
- Check the condition of key welding parts, power train parts and damping block. In case of any damage, repair, adjust or change them.

5.4 Maintenance Schedules

5.4.1 Introduction

- The technical maintenance for the roller is divided into three kinds, namely routine maintenance, regular maintenance and one-off maintenance (troubleshooting).
- The intervals regulated in regular technical maintenance are the same with those specified in the Engine User's Guide.
- The engine shall be maintained in accordance with the Engine User's Guide.

5.4.2 Roller Maintenance Locations

The following view is a general guide for service or maintenance locations on the roller.

NOTICE

Risk of machine damage!

Failure to perform the outlined maintenance listed in this maintenance section could result in shortened service life of the machine or a system failure during operation.

Strictly maintain the machine under the guidance of this manual.

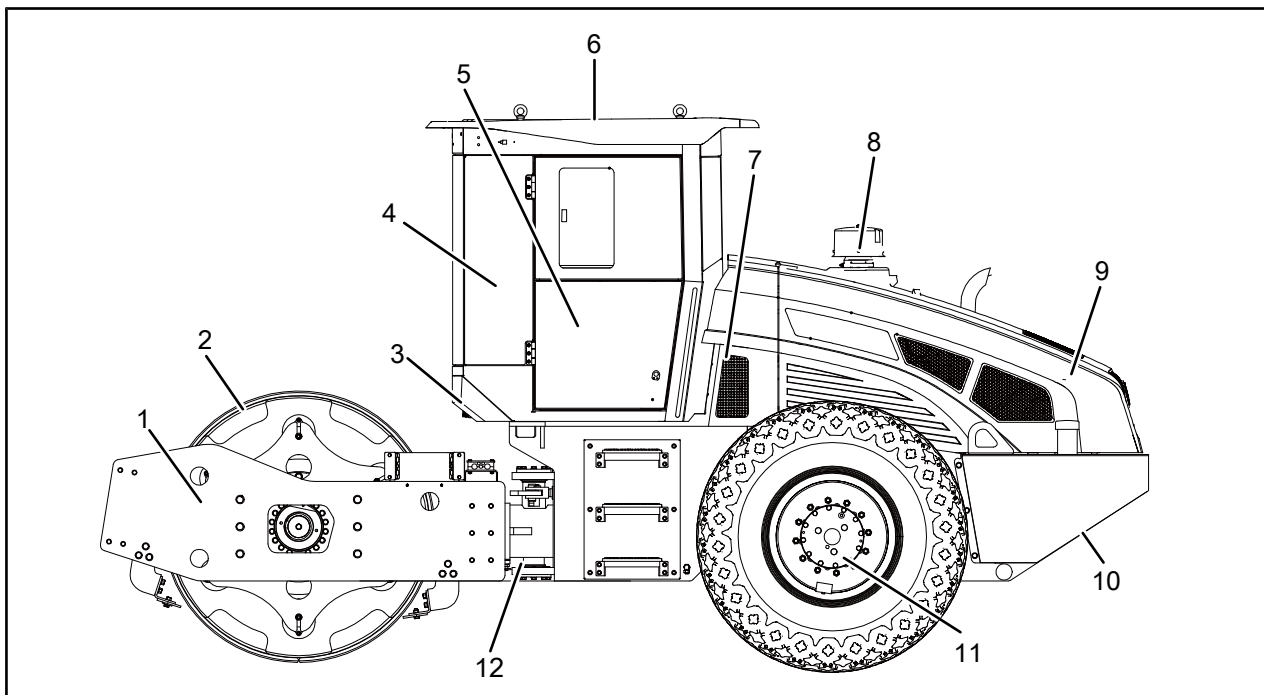

Fig 5-1

- | | | | |
|--|-----------------------------|----------------------------|--------------------------------|
| 1. Front frame | 4. Control system | 7. Air conditioning system | 10. Rear frame |
| 2. Vibratory drum (drum with assembled pad foot is optional) | 5. Electrical system | 8. Power system | 11. Rear axle assembly |
| 3. Hydraulic system | 6. Cab (canopy is optional) | 9. Engine hood | 12. Central articulation frame |

5.4.3 Routine Maintenance

NOTE :

The time for regular maintenance is calculated from the engine start. Every time after 1000 h regular maintenance, the roller enters into the next new cycle of regular maintenance.

Prior to any maintenance, confirm the following items:

- Place the machine on even ground, shut down the engine, and remove the ignition switch key.
- Apply the parking brake switch.
- Ensure all components of the roller cool down.
- Prepare proper container.

NOTE :

Only when the engine's running is required during lubrication and maintenance, can the engine keep running.

1. Clean the roller.

- Remove the mud, sands and gravels on the roller.
- Remove the sands and mud on the engine and hydraulic elements.
- Remove the sands on the tires.
- Keep all oil fillers clean.

NOTE :

Do not use corrosive detergent for cleaning. Non-fiber cloth is recommended.

2. Check the parts for tightness

Check the connection bolts and pipe clamps for looseness and breakage. Tighten or replace the loose or broken bolts and pipe clamps.

3. Check for oil leakage

- Check under and around all sides of the roller.
- Check the pump, motor, multi-way valve, valve body, hose, flange and other connections for leakage.
- Check the engine for leakage.
- Check the muffler line for leakage.
- Check the A/C lines for leakage.

4. Check electric circuit

- Frequently check the harness connectors for water and oil. Keep them clean.
- Check the connectors and nuts at lamps, sensors, horn and brake pressure switch for looseness.
- Check the harness for short circuit, open circuit and damage. Keep the harness in good condition.

- Check the wiring in electric control cabinet for looseness.

5. Check key welding parts/power train parts

- Check welding parts of the frame and the drum for crack. If any, weld or repair them.
- Check power train parts for deformation.
- If you shall perform welding work on the machine, pay attention to protection and treatment of painting, electrical cables or hydraulic hoses. If the parts to be welded is close to the fuel tank, be careful of catching fire.

6. Check oil and water level

- Check the level of lubricant, fuel and hydraulic oil. Fill new fuel/oil up to the specified mark.
- Check the water level in combined radiator, and fill water to the required volume.

7. Check light

Check whether the forward working light, cabin working light and other lights are on, whether there is dirt or damage.

8. Check Horn

Check the function of the horn, be sure it is operational.

9. Check operating functions

Check that all functions in the operating cabin work correctly.

10. Check vibratory drum

Check the connection of the hydraulic hoses on the motor and the reducer for the vibratory drum, and ensure that they are in good condition.

5.4.4 Engine–Store

If the engine will not be used for a long time, we recommend to store the engine according to the following procedures to prevent corrosion.

1. Clean the engine including the cooling system with cold detergent and water gun, or best of all, steam.
2. Run the engine until the moisture on the surface is evaporated .
3. Drain the warm engine oil and fill anticorrosion oil.
4. Drain the coolant and fill antifreeze and coolant.
5. Drain the fuel in the fuel tank, mix it with anti-corrosion oil at a ratio of 10:1 and then fill the mixed fuel into the tank again.

6. Run the engine for 10 minutes till the anticorrosion mixed diesel enters all pipelines, filters, pumps and nozzles and the new engine oil is distributed to all parts.
7. Turn the engine crankshaft (the engine not started) for several times to make the anti-corrosion mixed fuel injected into the combustion chamber.
8. Remove belts, spray anti-rust oil into the belt pulley oil groove and loosen the belts of alternator, cooling fan and A/C compressor. Clear away all anti-rust oil before restarting the engine.
9. Seal the air filter inlet and engine exhaust port. Reopen the inlet and exhaust port before restarting the engine.

5.4.5 Short-time Storage–Maintain

If the roller storage time is less than 3 months, see [“Park Brake” on page 4-21](#).

5.4.6 Long-time Storage–Maintain

If the roller is to be stored for 3 months or even longer, maintain it in accordance with the following instructions:

- Perform the maintenance for long-time storage and rust-proof treatment in accordance with the Engine User’s Guide.
- Clean the inner and outer surfaces of the roller. Park it in the garage if available or at a ventilated place in the open air and cover it with canvas.
- Block up the front and rear frames in parallel. Adjust the adjusting pads until the damp blocks are not under stress. Connect and fix the front and rear frames with the limit plate.
- Lubricate the roller through each lubricating point.
- Clean the surface of vibratory drum. Wipe it with a piece of cloth and then coat some anti-rust paint. Apply anti-rust oil on the exposed machined parts of vibratory drum.
- Remove the storage battery and check the electrolyte level. Charge the battery once a month.
- Seal the air filter, dust port and exhaust pipe outlet with plastic or paper tape to keep the engine free of moist air.
- Fill up the fuel tank to avoid condensation and rust.
- Fill the hydraulic oil tank up to the mark “Max”.
- Turn on/off the A/C for about 10 minutes monthly.
- Turn on/off the heating system for about 10 minutes monthly.

5.4.7 Post-maintenance Roller–Check

After maintenance, check the machine.

Check the following items when the machine runs:

- Ensure the engine or the hydraulic system has no abnormal noise.

- Check all systems for leakage after maintenance.
- Check all systems for looseness or abnormal movements after maintenance.
- Check if all systems are overheating after maintenance.

Check the following items when the machine stops:

- Ensure all maintenance items and their procedures in certain period are performed.
- Ensure all caps or plugs are installed and tightened in right positions.
- Ensure all locks are locked safely.
- Ensure no tools, replaced parts, nuts, bolts left on or in the machine.
- If any hydraulic components are replaced, drain the system completely. Ensure there is no leakage in the system and no distortion of pipelines.
- Record the maintenance notes and put it back to the original position. Fill the hydraulic oil tank up to the mark “Max”.

5.4.8 Regular Technical Maintenance Intervals

Before the next maintenance interval, finish all maintenance items for the current maintenance interval.

Table 5–10 Regular Technical Maintenance

Working Hours	Maintenance Items	Link
When require	Install/check battery	“Battery–Maintain” on page 5-49
	Replace fuse	“Fuel-Check/Refill/Replace” on page 5-37
	Replace compressor V-belt	“Compressor V-belt–Check/Replace” on page 5-48
	Fill washing fluid	“Windshield Washer Fluid–Check/Fill” on page 5-57
	Maintain electric box	“Electric Box-Maintain” on page 5-51
	Maintain long-time storage.	“Long-time Storage–Maintain” on page 5-19 and “Engine–Store” on page 5-18
	Check the machine after maintenance	“Post-maintenance Roller–Check” on page 5-19
Every day	Check/clean air filter	“Air Filter–Clean/Replace” on page 5-22
	Check engine air intake pipeline	“Engine Air Intake Pipeline–Check” on page 5-36
	Check engine oil level	“Engine Oil-Check/Refill/Change” on page 5-26.
	Check engine coolant level	“Engine Coolant-Check/Change” on page 5-34
	Check engine belt	“Engine Belt–Check/Replace” on page 5-36

Table 5-10 Regular Technical Maintenance (continue)

Working Hours	Maintenance Items	Link
	Check A/C system	“A/C-Check/Maintain” on page 5-45
	Check hydraulic oil level	“Hydraulic Oil-Check/Refill/Change” on page 5-41
	Check fuel level	“Fuel-Check/Refill/Replace” on page 5-37
	Check electric box	“Electric Box-Maintain” on page 5-51
	Check crankcase vent line	“Crankcase Vent Line-Check” on page 5-40
	Check oil tank and pipes	“Oil tank and Pipes-Check” on page 5-58
	Check damper	“Damper-Check/Replace” on page 5-57
	Check tires and rims	“Inspection before Starting” on page 4-3
50 working hours(initial)	Change engine oil	“Engine Oil-Check/Refill/Change” on page 5-26.
	Replace engine oil filter element	“Engine Oil Filter Element-Replace” on page 5-29
	Replace fuel filter	“Fuel Filter-Replace” on page 5-39
	Replace oil water separator	“Oil Water Separator- Check/Drain/Replace” on page 5-29
	Change rear axle lubricant	“Lubricant for Rear Axle-Replace” on page 5-56
	Check tension of engine belt	“Engine Belt-Check/Replace” on page 5-36
	Check tension of compressor V-belt	“Compressor V-belt- Check/Replace” on page 5-48
	Check and clean radiator	“Radiator-Check/Clean” on page 5-33
Every 500 working hours	Change engine oil	“Engine Oil-Check/Refill/Change” on page 5-26.
	Change rear axle lubricant	“Lubricant for Rear Axle-Replace” on page 5-56
	Change reducer lubricant	“Lubricant for Reducer-Replace” on page 5-55
	Replace air filter	“Air Filter-Clean/Replace” on page 5-22
	Replace engine oil filter element	“Engine Oil Filter Element-Replace” on page 5-29
	Replace fuel filter	“Fuel Filter-Replace” on page 5-39
	Replace oil water separator	“Oil Water Separator- Check/Drain/Replace” on page 5-29
Check central articulation frame and change lubricant	“Grease for Central Articulation Frame-Fill” on page 5-54	

Table 5–10 Regular Technical Maintenance (continue)

Working Hours	Maintenance Items	Link
	Change drum vibration bearing lubricant	“Lubricant for Drum Vibration Bearing-Replace” on page 5-54
	Check propel bearing and change lubricant	“Grease for Propel Bearing-Fill” on page 5-53
	Check engine belt, replace it if necessary	“Engine Belt–Check/Replace” on page 5-36
	Check compressor V-belt, replace it if necessary	“Compressor V-belt–Check/Replace” on page 5-48
	Check damper, replace it if necessary	“Damper-Check/Replace” on page 5-57
	Check and clean radiator	“Radiator–Check/Clean” on page 5-33
Every 1000 working hours	Change rear axle lubricant	“Lubricant for Rear Axle-Replace” on page 5-56
	Change hydraulic oil	“Hydraulic Oil-Check/Refill/Change” on page 5-41
	Change hydraulic oil filter	“Hydraulic Oil Filter–Replace” on page 5-44
	Replace coolant	“Engine Coolant-Check/Change” on page 5-34
	Check A/C system, clean or replace it if necessary	“A/C-Check/Maintain” on page 5-45
	Check and clean radiator	“Radiator–Check/Clean” on page 5-33
Every 2000 working hours	Replace DEF tank filter	Contact sany service personnel to replace DEF tank filter
Every year	Replace fuel	“Fuel-Check/Refill/Replace” on page 5-37
	Check/clean air filter	“Air Filter–Clean/Replace” on page 5-22
	Replace coolant	“Engine Coolant-Check/Change” on page 5-34

5.5 Maintenance for the Power System

5.5.1 Air Filter–Clean/Replace

Air filter–clean

NOTICE

Risk of machine damage!

Dust is drawn into the engine. And this could badly shorten the service life of the engine.
Never start the engine after the air filter is removed.

1. Open the covering parts.
2. Remove the end cover of the air filter.

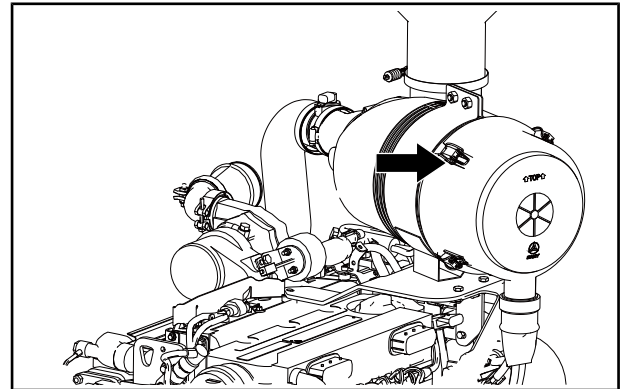

Fig 5-2

3. Clean the end cover and the dust evacuator.

NOTICE

Risk of machine damage!

Clean the filter element with gasoline or hot liquid could cause damage to the air filter.
Never clean the filter element with gasoline or hot liquid. After cleaning, check the filter element for damage with a pocket lamp. Replace the filter element if its paper dusting ball or seal lip is damaged.

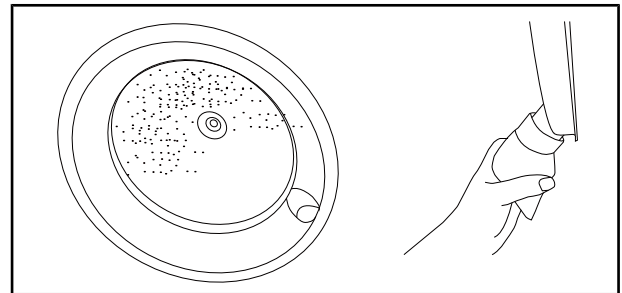

Fig 5-3

Air filter—replace**NOTICE**

Risk of engine damage!

Cleaning 3 times or blackening of the main filter element turns black could be harmful to engine.
Replace the main filter element with a new one.

When the engine is in operation, if the air filter warning lamp flashes, you should maintain the air filter.

Take the following steps to maintain the air filter.

1. Open the covering parts.
2. Take off the cover of the air filter.
3. Clean the end cover and the dust valve.
4. Carefully pull the dirty air filter main element out of the air filter housing, then discard the dirty air filter main element properly. Pull the main filter element out of the housing carefully to avoid contact between the filter elements and the housing.

NOTE :

The main filter is installed on the air intake port for sealing the interior filter cover. Take off the element with care to reduce released dust. If the air filter element is dirty or looks abnormal, it is at the end of its service life. Replace the element with a new one. If the air filter main element shows no signs of excess dirt accumulation or if no abnormalities are found, leave air filter main element in place. The safety element will be replaced with the main element together.

5. Check the used main filter element. The main filter element used can display foreign particles causing leakage on the sealing surface. The linear dust on the air side of the filter may leak. Clear the items before fixing a new filter.

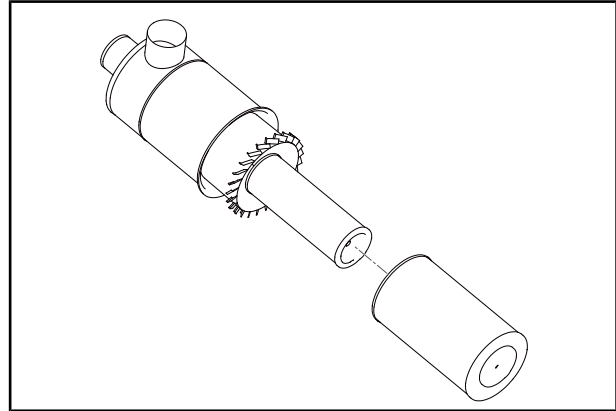

Fig 5-4

NOTICE**Risk of machine damage!**

Cleaning the filter element by knocking and tapping could cause damage to filter paper.

Clean the filter element by dry compressed air (pressure less than 0.5 MPa) when the air filter alarm sounds.

6. Use dry compressed air (pressure less than 0.5 MPa) to blow along the inside of the pleats toward the main filter element, and then direct the compressed air along the outside of the pleats to blow from interior to exterior. The safety filter element is not allowed to be cleaned.

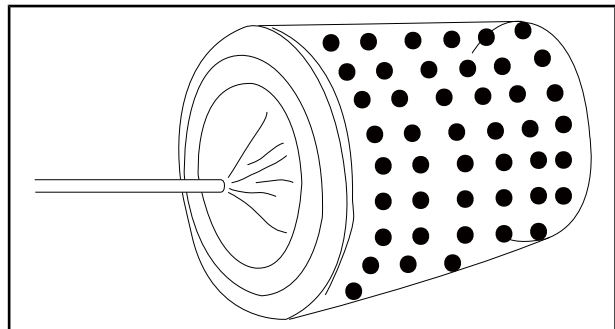

Fig 5-5

7. It's advised to change the main filter element if it has been cleaned for three times. Meanwhile the safety filter element should be changed as well.

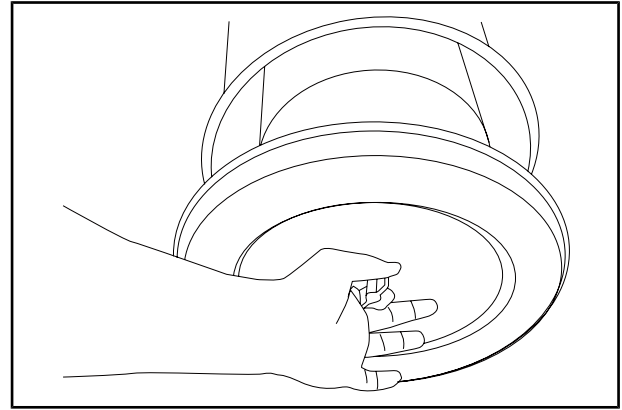

Fig 5-6

8. If the main filter element is damaged, the main filter element and safety element must be replaced regardless the cleaning times is three or not.

9. Reinstall the air filter.

NOTICE

Risk of machine damage!

Never install a damaged filter element, otherwise it could lead to engine fault and shorten service life of the engine.

Inspect the filter carefully and install a filter element in good shape.

1) Insert the filter element. See in right figure. Check the filter element, especially inside face of opening for damage due to transportation, clean and improper hold.

2) Install the front housing cover and tighten the mounting clamps. The dust evacuator must be assembled facing downwards.

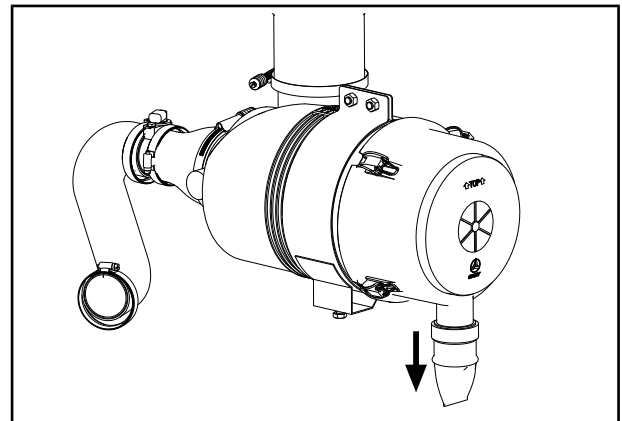

Fig 5-7

NOTE :

In harsh environment with high intensity of dust , service and maintenance interval of air filter are reduced based on the application.

It is recommended to inform SANY service personnel of maintaining air filter. Customer is responsible for any consequences caused by his own wrong maintenance for air filter.

5.5.2 Engine Oil-Check/Refill/Change

Engine oil-check/refill

CAUTION

Risk of personal injury!

Do not drain the engine oil when the engine has just been shut down and the engine oil is still hot. Otherwise, you could be burned by the hot engine oil.

Drain the engine oil after the oil gets cold.

Take the following steps to check the engine oil level :

1. Take out oil dipstick and wipe the oil off the dipstick with clean cloth.

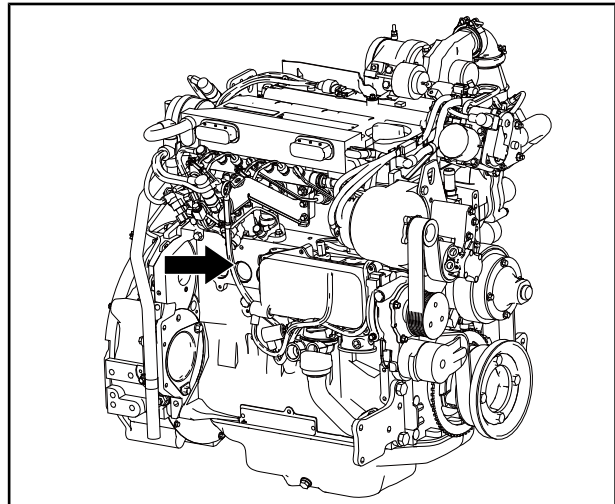

Fig 5-8

2. Insert the oil dipstick to bottom and then pull it out. The oil level should be in the diagonal range on the oil dipstick (1) .

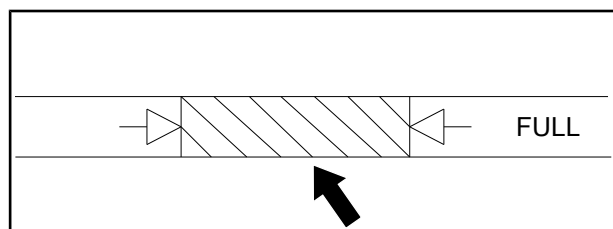

Fig 5-9

3. Oil level should be between the diagonal range on dipstick. Add recommended engine oil through oil filler neck if oil level is lower than the diagonal range.

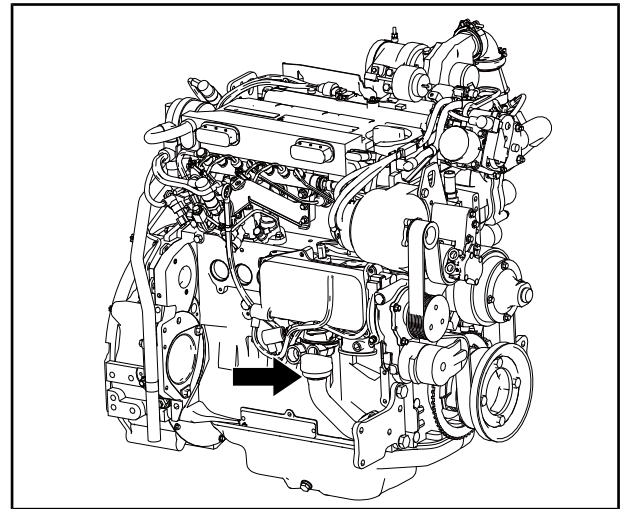

Fig 5-10

4. If oil level is above the diagonal range, open the plug at the engine oil outlet to drain extra engine oil. Check oil level again.

NOTE :

The engine oil outlet is located under the DEF tank.

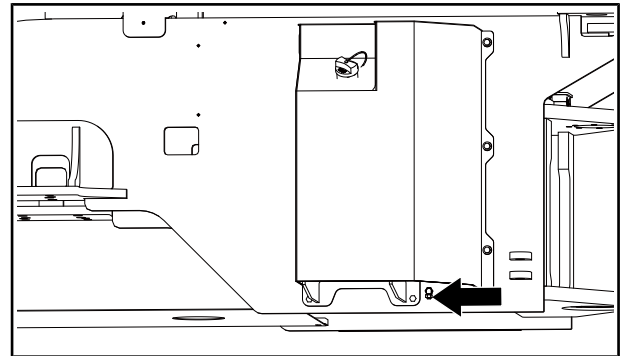

Fig 5-11

Engine Oil-change

⚠ CAUTION

Risk of personal injury!
The hot engine oil could lead to scald if it contacts with skin.
Avoid the engine oil contacting your skin.

NOTICE

Risk of engine damage!
If the engine is turned on while the oil is being drained, the engine could suffer serious damage.
Never start the engine when draining the engine oil.

1. Place the machine on even ground.

2. Start the engine and warm up for a while. Then switch the ignition switch to the OFF position to stop the engine.

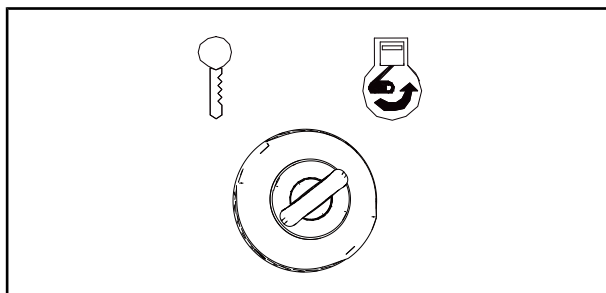

Fig 5-12

3. Put the oil receiving vessel below the engine oil outlet.

NOTE :

The engine oil outlet is located under the DEF tank.

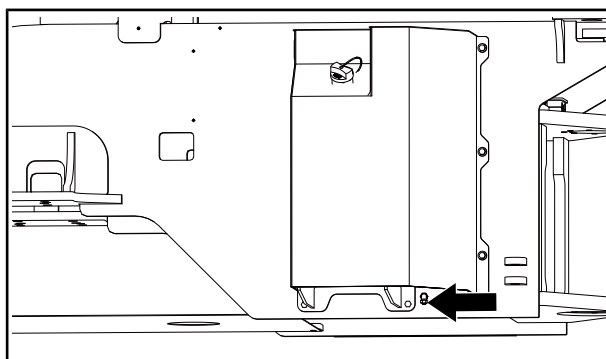

Fig 5-13

4. Unscrew the plug at the engine oil outlet .
5. Discharge the engine oil .
6. Screw the plug back. Then fill the recommended (see ["Filling Capacities"](#) on page 5-14) engine oil through oil filler neck.

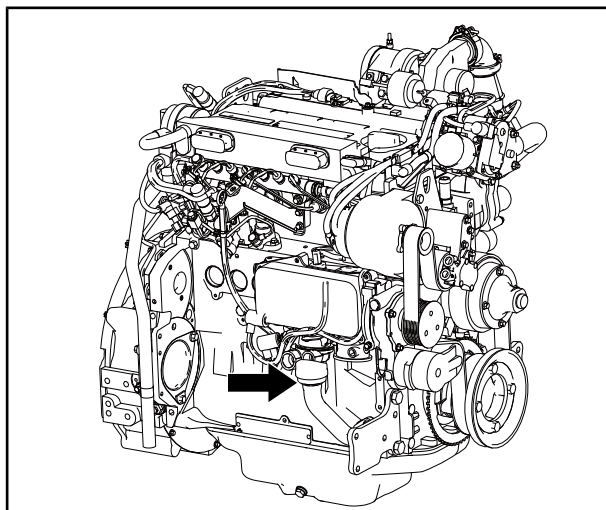

Fig 5-14

7. Start the engine and check the plug for leakage. If leakage appears, screw the plug again.
8. Shut down the engine. Wait until the engine cools down, then check the engine oil level.

5.5.3 Engine Oil Filter Element–Replace

⚠ CAUTION

Risk of personal injury!

Maintain the equipment when the engine oil is still hot could cause burn.

Wait until the engine cools down before maintenance and use protective equipment to protect your skin.

NOTICE

Risk of machine damage!

Engine oil flowing out from the pipe line could cause engine lack of lubricating and machine damage.

Never start the engine when the engine oil filter element is removed.

1. Thoroughly clean the outside of the filter.
2. Use a proper tool (belt spanner) to clamp the filter element.
3. Remove the filter element.
4. Clean the sealing on the filter carrier from any dirt.
5. Slightly oil the rubber seal on the new filter.
6. Screw up the new filter element by hand until the seal contacts.
7. Tighten the filter element for another half turn.
8. Check the filter element for leak.

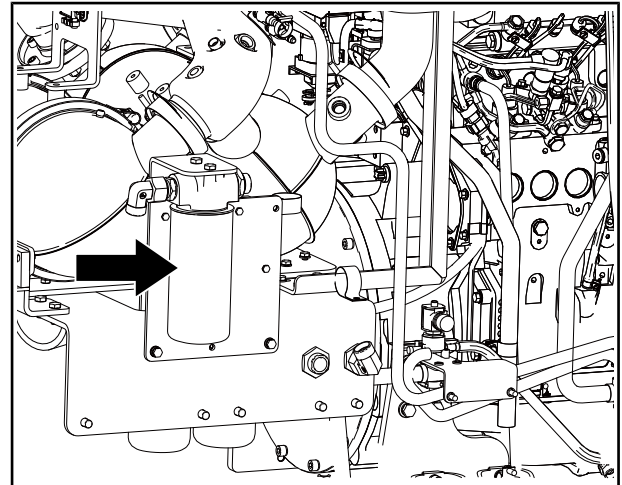

Fig 5-15

5.5.4 Oil Water Separator–Check/Drain/Replace

The oil water separator–check/drain

⚠ WARNING

Risk of death or personal injury!

Fire could be caught when working on the fuel system with open fire, which could result in death or personal injury.

When working on the fuel system, do not use open fire, smoke or spill any fuel.

Take the following steps to check the oil water separator.

1. Open the covering part.
2. In case of water or sediment built up at bottom, place a vessel under the oil water separator and to open the drain valve to drain the water and sediment.

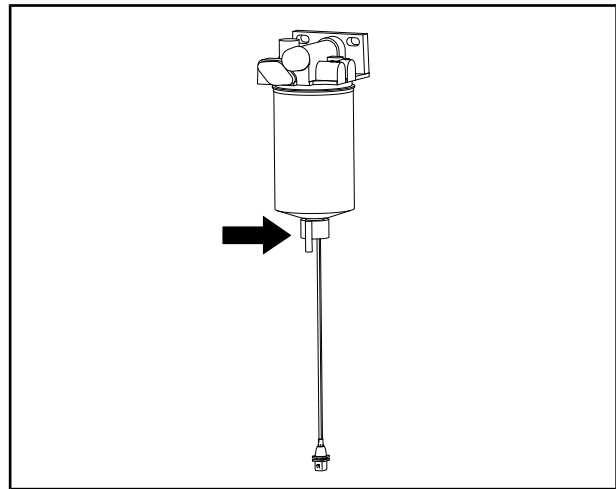

Fig 5-16

3. When fuel is seen coming out of the drain hoses, close the drain valves immediately.

Besides, check the hoses and pipe connector for looseness to avoid the air going into the pipeline.

The oil water separator—replace

⚠ WARNING

Risk of death or personal injury!

Open fire and smoke could cause fire when working on the fuel system, which could result in death or personal injury.

When working on the fuel system, do not use open fire, smoke or spill any fuel.

NOTICE

Risk of machine damage!

Insufficient fuel could cause the engine to work inefficiently or even shut down, which could shorten the service life of the engine.

The engine must be shut down before changing the oil water separator.

Take the following steps to change the oil water separator.

1. Put a container under the filter and disassemble the filter with a special spanner.

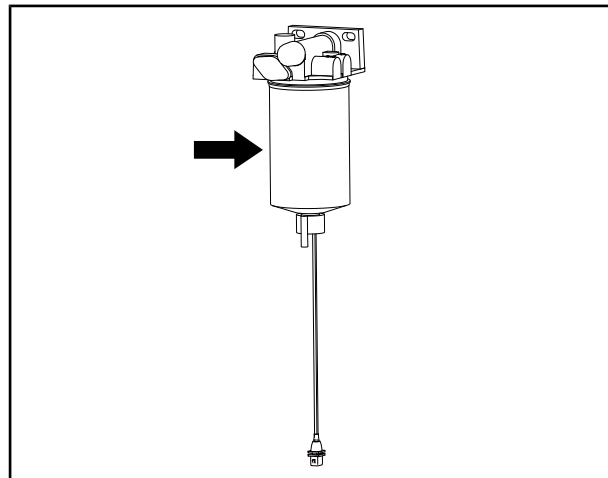

Fig 5-17

2. Clean the sealing on the filter carrier from any dirt.
3. Unscrew the water separator from the filter cartridge.
4. Apply a thin coat of oil to the rubber seal of the water separator.

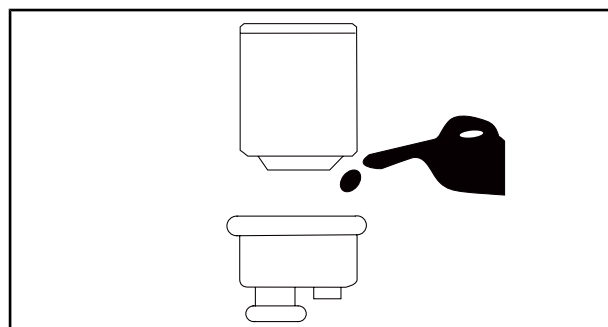

Fig 5-18

5. Screw the water separator on by hand, until the seal contacts.

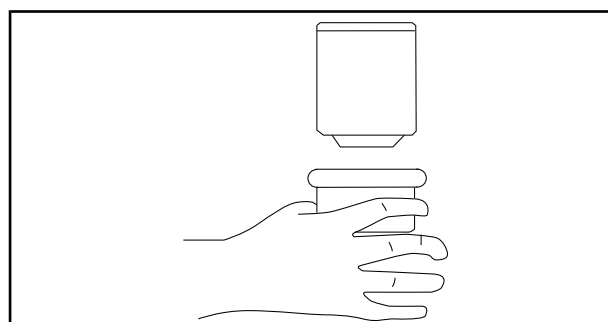

Fig 5-19

6. Tighten the water separator for another half turn.

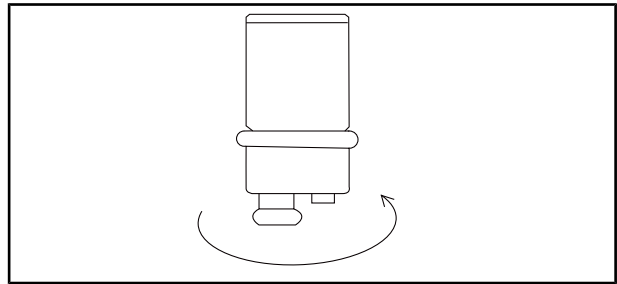

Fig 5-20

7. Fill the filter cartridge with clean fuel.

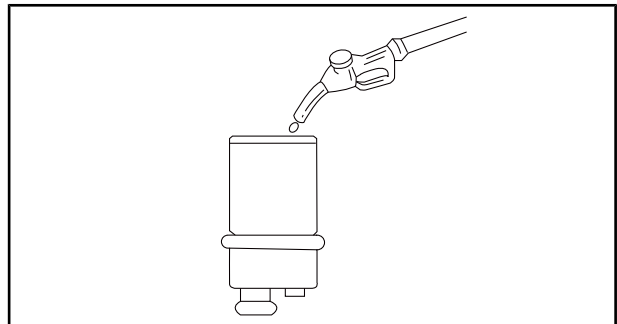

Fig 5-21

8. Apply some oil to the rubber seal of the filter element and screw it on by hand, until the seal contacts.

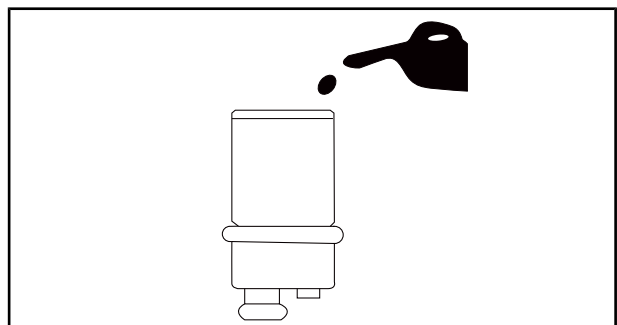

Fig 5-22

9. Tighten the filter element for another half turn.

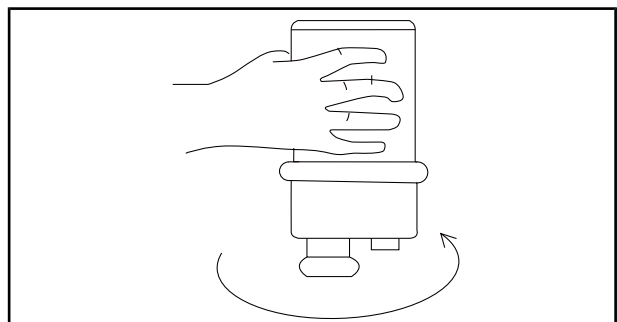

Fig 5-23

10. Release the air that possibly mixed in the fuel pipeline by pressing the position shown in the figure.

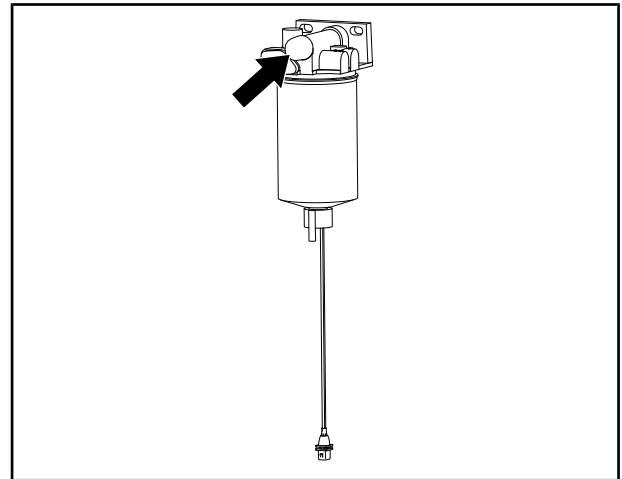

Fig 5-24

11. Check the filter element for leaks after a short-time test run.

5.5.5 Radiator–Check/Clean

CAUTION

Risk of personal injury!

Hot engine and radiator could cause burn.

Perform cleaning work only after the engine and radiator have cooled down and with the engine stopped.

Take the following steps to clean the radiator under different block conditions :

1. The radiator core is blocked, and the air flow is relatively uniform (under rated speed) with sundries loosely adhere to the surface:

- 1) Clean the sundries on the surface.
- 2) Clean the air inlet and outlet sides with compressed air until no sundries are blown out and the outlet air is uniform before use.

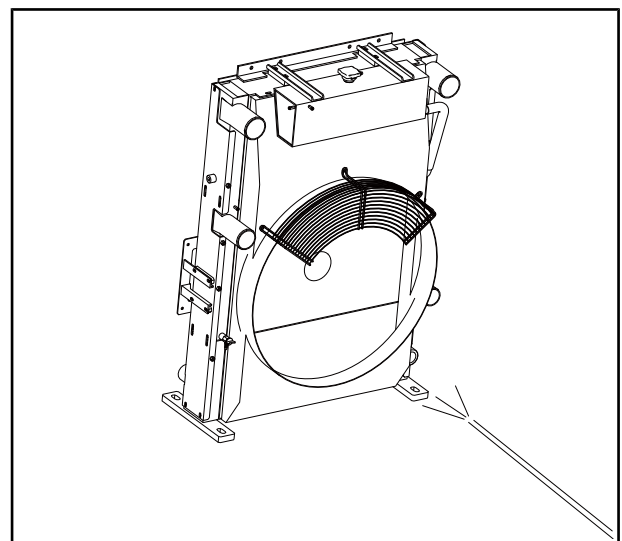

Fig 5-25

2. The radiator core is blocked, and the air flow is small or no air flow (under rated speed) with sun-dries firmly adhere to the surface :

- 1) Empty the engine coolant.
- 2) Remove the radiator form the machine.
- 3) Clean the radiator core with compressed air or water gun.
- 4) Reassemble the radiator.

When cleaning the radiator core (fins), the pressure of the compressed air should be not more than 0.2 MPa, the distance between the air outlet face and the radiator core should be not less than 50 mm, the pressure of the high pressure water should be not more than 0.27 MPa, and the distance between the high pressure water outlet face and the radiator core should be not less than 100 mm.

During the cleaning process, do not spray water directly to the generator, cables and electrical parts. After cleaning, start the engine after the moisture is evaporated.

5.5.6 Engine Coolant-Check/Change

Liquid level of engine coolant-check

⚠ CAUTION

Risk of personal injury!

People could easily be burned by the hot coolant spilling from radiator.

Change the coolant only after the engine cools down.

Take the following steps to check engine coolant level.

1. Open the cover of the radiator when engine is in cool condition.
2. The level of the coolant is 15 millimeters below the inner top surface of the radiator.
3. When coolant in radiator is not enough, fill it with the recommended coolant ([see "Filling Capacities" on page 5-14](#)) to the required level.
4. Check the sealing of the water intake port and water outlet port.

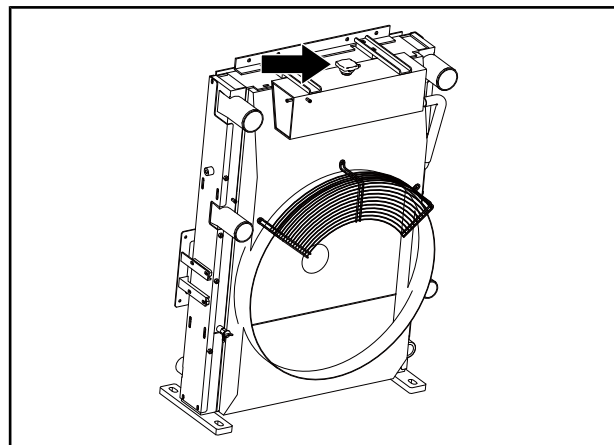

Fig 5-26

The coolant-change

Take the following steps to change the coolant:

1. Unscrew the cover after the coolant cools down lower than 50 °C

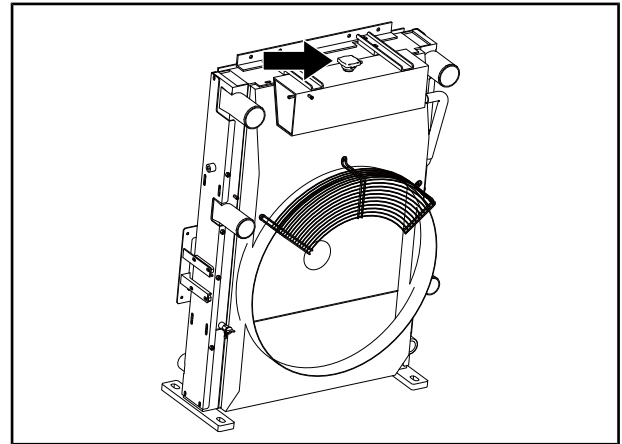

Fig 5-27

2. Place a vessel (volume should be more than 33 L) under the coolant outlet. Remove the plug on the left side of the rear frame.

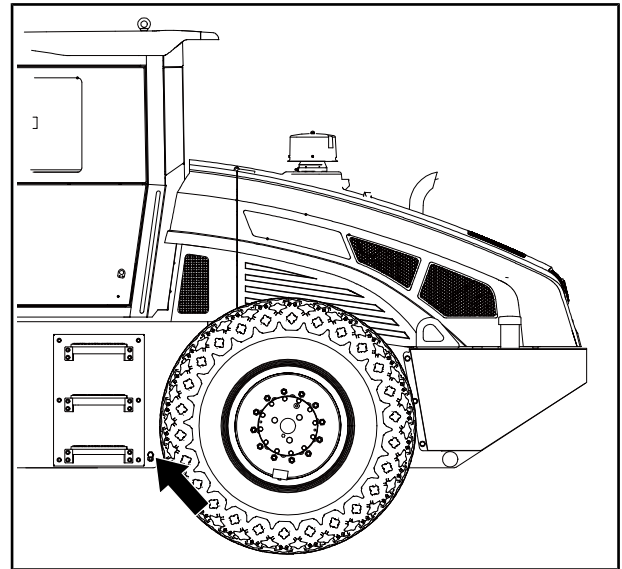

Fig 5-28

3. Screw the plug back. Then fill the new coolant (**See “Filling Capacities” on page 5-14**) through the inlet.
4. Screw the cover back.
5. Wait until the engine cools down, then check the coolant level. If the coolant level is lower than the specified height, add it again.

5.5.7 Engine Belt–Check/Replace

⚠ WARNING

Risk of personal injury!

Working on the engine belt during it's operation could cause personal injury.

Work on the engine belt only when the engine shut down.

The engine belt (1) can be tensioned automatically by the tensioner (2).

Check the condition of the engine belt (1). If excessive wear happens, replace the engine belt (1). Take the following steps to tension the engine belt (1):

1. Press the tensioner to loosen the engine belt (1).
2. Remove the old engine belt (1) and replace it with a new one.
3. The tensioner (2) will tension the engine belt automatically.

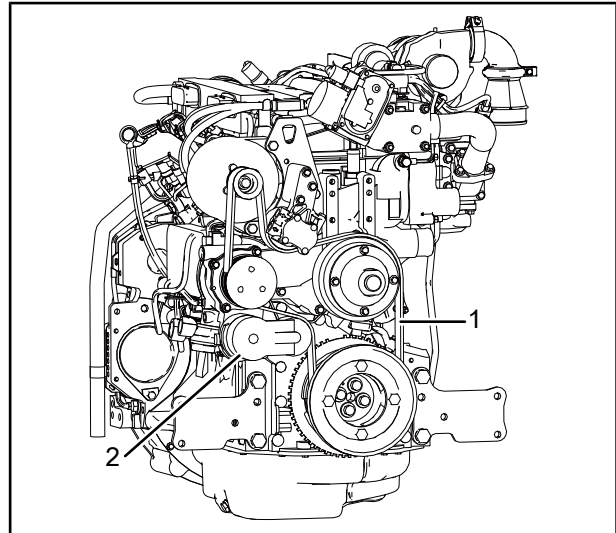

Fig 5-29

1. Engine belt

2. Tensioner

5.5.8 Engine Air Intake Pipeline–Check

1. Check the T clamps (1) for looseness. In case of loose clamp, tighten it.

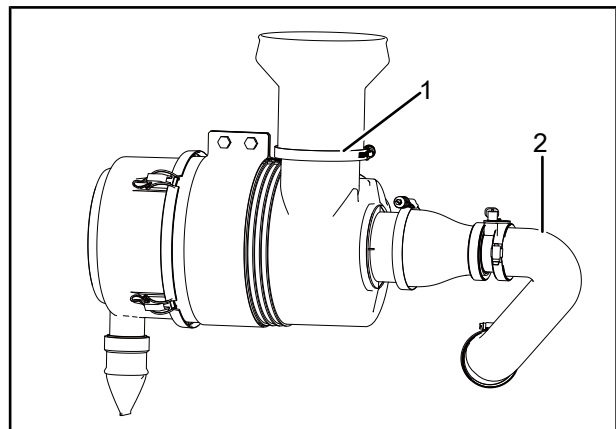

Fig 5-30

1. T clamp

2. Rubber hose

2. Check the rubber hose (2) for damage or leakage. If any, replace them.

5.5.9 Fuel-Check/Refill/Replace

Fuel-check/refill

If fuel level indicator flashes, it means the fuel is going to be empty. You have to fill the fuel tank with the appropriate fuel.

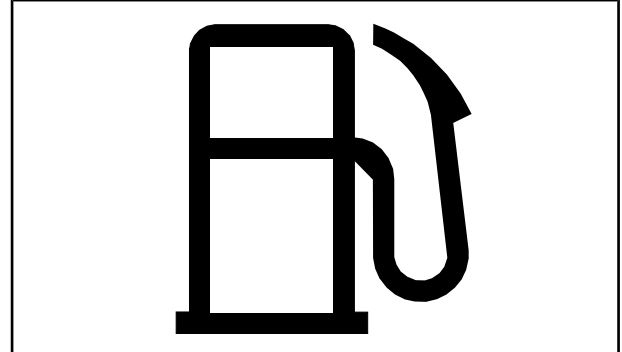

Fig 5-31

The fuel tank is welded on the left side of the rear frame. Take the following steps to fill the fuel tank.

1. Select a well-ventilated place.
2. Clean the dust around the filler.
3. Open the lock cover (1) of fuel tank, and fill the fuel tank with appointed fuel through the filler pipe (2).

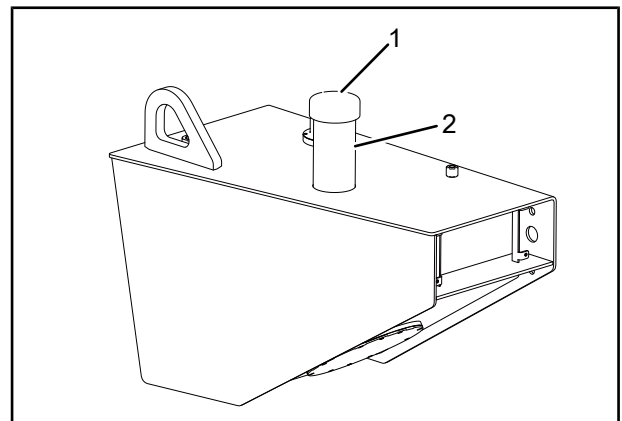

Fig 5-32

1. Lock cover

2. Filler pipe

4. While the fuel level pointer leaves the "E" area, the fuel level alarm indicator icon goes out. When the fuel level pointer gets the point that you want, stop filling.

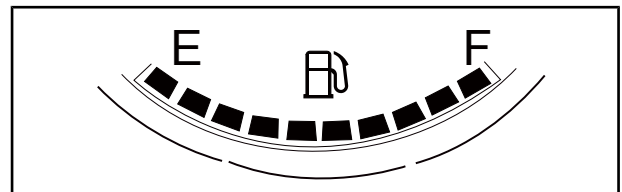

Fig 5-33

NOTE :

The fuel level sensor detection range : 0 - 180L

5. Install the lock cover (1) of fuel tank.

Fuel-change**⚠ WARNING**

Risk of death or personal injury!

Open fire and smoke could cause fire during working on the fuel system, which could result in death or personal injury

When working on the fuel system do not use open fire, smoke and spill any fuel.

NOTICE

Risk of machine damage!

Insufficient fuel could cause the engine to work inefficiently or even shut down. This could shorten the service life of the engine.

The engine must be shut down before changing the fuel.

The following steps show how to change the fuel :

1. Blow the outside of tank with compressed air to remove the dust.

NOTE :

The purity of the fuel should be guaranteed. Otherwise the impurity such as dust will make the oil water separator to invalidate more easily and bring big resistance of fuel suction.

2. Place a container under the drain port (2) and unscrew the bolts to drain the oil.

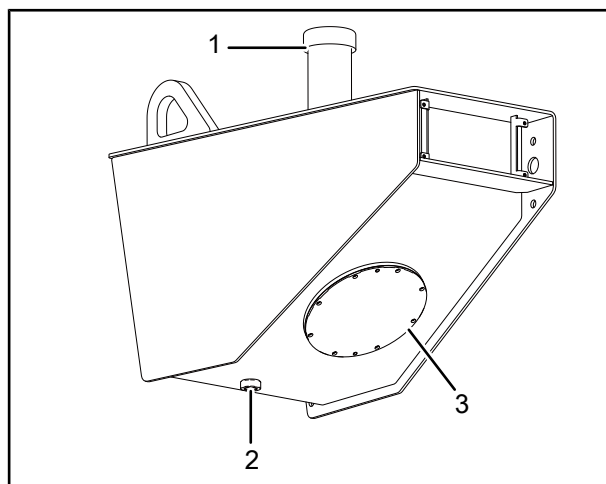

Fig 5-34

- | | |
|---------------|----------------|
| 1. Lock cover | 3. Cover plate |
| 2. drain port | |

3. Unscrew the bolts and remove the cover plate (3) of the tank. Blow out the oil and grain materials left in the fuel tank, especially the blind corner with compressed air.

4. Refill an appropriate amount of clean diesel oil (or kerosene) into the fuel tank. Use a new brush to clean the tank up and down. When the oil gets dirty, change it with new oil and continue cleaning till no dirt and sediment are found on the wall and bottom of tank.
5. Install the bottom cover plate (3) and screw the bolts at the drain port (1) tightly.
6. Open the lock cover (1) and refill the tank with appointed fuel ([see "Filling Capacities" on page 5-14](#)).
7. Before starting the engine, operate the oil-water separator to discharge the air in the fuel pipeline.

5.5.10 Fuel Filter–Replace

! WARNING

Risk of death or personal injury!

Open fire and smoke could cause fire when working on the fuel system, which could result in death or personal injury.

When working on the fuel system do not use open fire, smoke or spill any fuel.

NOTICE

Risk of machine damage!

Insufficient fuel could cause the engine to work inefficiently or even shut down. This could shorten the service life of the engine.

The engine must be shut down before changing the duplex fuel filter.

Take the following steps to change the fuel filter:

1. Remove the filter element with a special spanner.

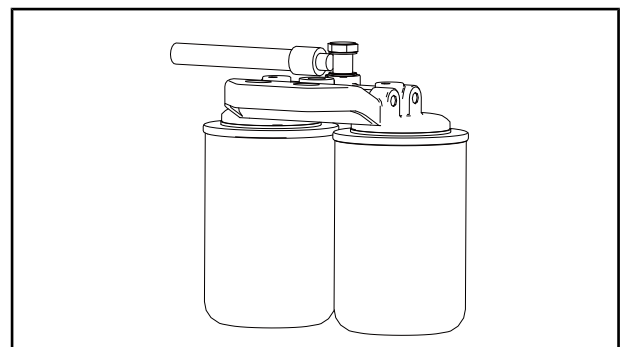

Fig 5-35

2. Put a container below the filter element to drain the diesel.
3. Oil the rubber seal on the new filter slightly.
4. Fill the new diesel in the new filter.

5. Screw up the new filter element by hand until the seal contacts.
6. Tighten the filter element for another half turn.
7. Release the air that possibly mixed in the fuel pipeline by pressing the manual pump up and down before starting the engine.
8. Check the filter element for leaks after a short test run.

5.5.11 Crankcase Vent Line–Check

Check the crankcase vent line for leakage or blockage. If any, do troubleshooting.

NOTE :

If any leakage or blockage in the crankcase vent line occurs, contact your SANY distributor. It is forbidden to perform any maintenance on the engine by yourself. In reference to any key parts of the engine and the engine faults, please consult your SANY distributor. Otherwise SANY bears no liability

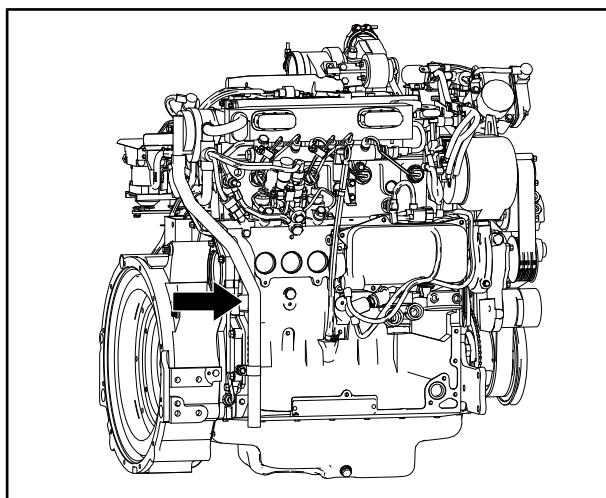

Fig 5-36

5.5.12 Aftertreatment System - Check/Fill

Diesel Exhaust Fluid (DEF) - Check

The steps for check the DEF level has been described before. See [“Check the Diesel Exhaust Fluid \(DEF\) Level” on page 4-13.](#)

Diesel Exhaust Fluid (DEF) - Fill

1. Prepare the machine for service.

2. Remove diesel exhaust fluid (DEF) tank filler cap.

NOTICE

Cleanliness is important when working with an open diesel exhaust fluid (DEF) system. Contaminated DEF can result in engine damage.

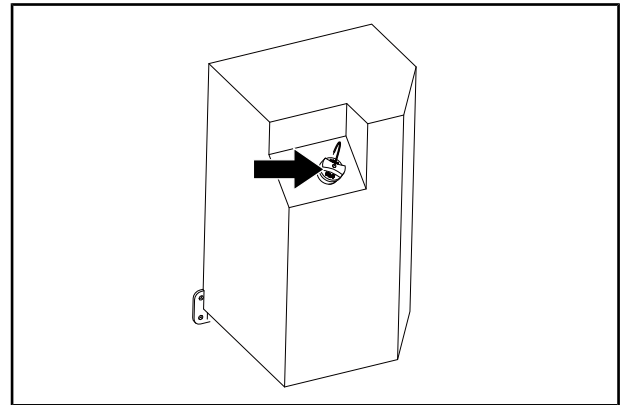

Fig 5-37

NOTE :

For fuel capacities, see [“Filling Capacities”](#) on page 5-14.

3. Add fresh diesel exhaust fluid (DEF) to tank.

NOTE :

Add at least 10 L DEF each time.

4. Install diesel exhaust fluid (DEF) filler cap.

NOTE :

The DEF tank filter should be replaced every 2000 hours, contact Sany service personnel for filter replacement.

5.6 Maintenance for the Hydraulic System

5.6.1 Hydraulic Oil-Check/Refill/Change

⚠ CAUTION

Risk of personal injury!!

If the engine has been just shut down and you plan to work on hydraulic components and hydraulic oil, it could badly burn your skin.

- Wait for components to cool down before working on them.
- When removing the lube filter for oil filling, turn it slowly to release internal pressure before removing it.

NOTICE

Risk of machine damage!

Impurity could cause great damage to the hydraulic element.

Change the hydraulic oil under the working temperature.

NOTE :

Except for the regular hydraulic oil change, replacement should be made as well after overhaul. Otherwise the hydraulic elements will be worn more easily.

Hydraulic oil-check/refill

Take the following steps to check hydraulic oil level :

1. Stop the machine on a flat ground and straighten the wheels.
2. Do service brake and turn the key to position ON.

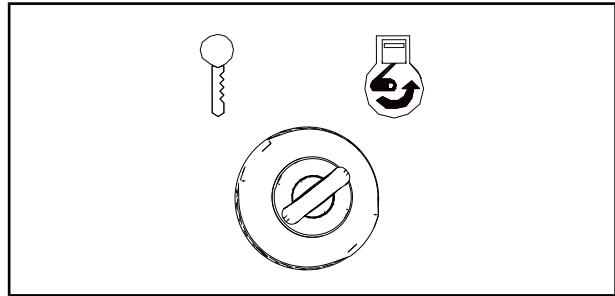

Fig 5-38

3. The hydraulic oil tank is welded on the rear frame. The level gauge is mounted on the hydraulic oil tank to show the level in the tank. Normally, the level is between 2/3 ~ 3/4 of the level gauge.

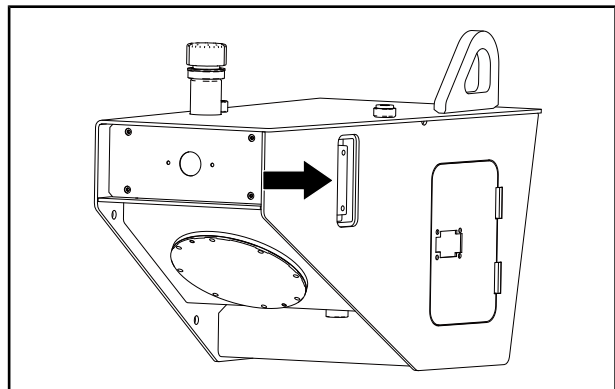

Fig 5-39

When the level is lower than the 2/3 of the level gauge, take the following steps to fill the hydraulic tank.

1. Clean around the hydraulic oil tank.
2. Remove the filter cap (1).
3. Fill the tank with the appointed hydraulic oil.
4. When the level is between 2/3 ~ 3/4 of the level gauge , stop filling.
5. Clean and install the filler cap (1) of hydraulic oil tank.

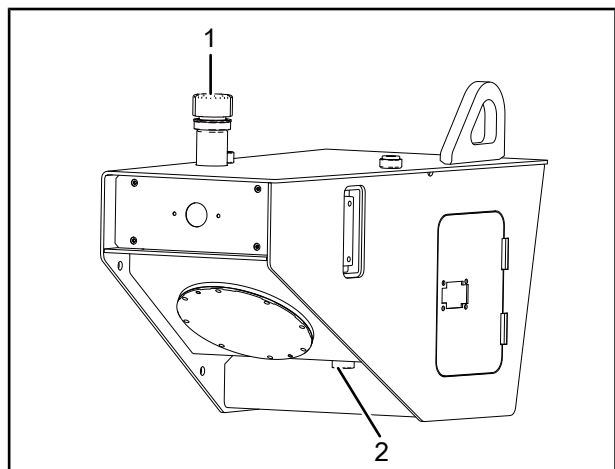

Fig 5-40

1. Filler cap

2. Oil outlet port

When the level is higher than the 3/4 of the level gauge, take the following steps to drain the extra hydraulic oil.

1. Clean around the hydraulic oil tank.
2. Place a vessel under the oil outlet port (2).
3. Remove the screw at the oil outlet port (2) to release the extra hydraulic oil.
4. When the level is between 2/3 ~ 3/4 of the level gauge, stop draining.
5. Clean and install the screw at the oil outlet port (2).

NOTE :

The hydraulic oil level will be different before and after the start of the engine. Inspect the hydraulic oil level before formal construction and add oil again if necessary (the oil level should be between 2/3 ~ 3/4 of the level gauge).

NOTE :

Changes in ambient temperature will also cause the changes in hydraulic oil level.

Hydraulic oil-change

NOTICE

Risk of machine damage!

Starting the engine when draining the hydraulic oil could cause damage to the whole hydraulic system.

Never start the engine when draining the hydraulic oil.

Changing procedures:

1. Start the engine till the hydraulic oil warms up. Then stop the engine.
2. Clean around the hydraulic oil tank and oil filler.

3. Remove the filler cap (1) of the hydraulic oil tank. Remove the screw at the oil outlet port (3) of the oil tank and collect the oil with a container.

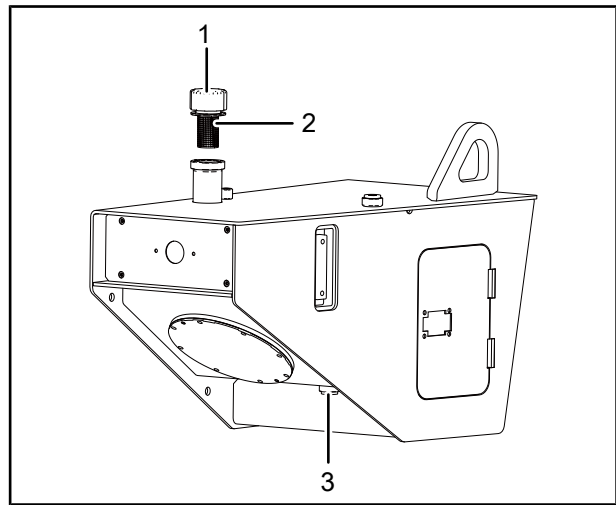

Fig 5-41

1. Filler cap 3. Oil outlet port
2. Air filter screen

4. Replace the air filter screen(2). Wash the air filter screen (2) with solvent and dry it in the air.
5. Fit the screw at the oil outlet port (3) .
6. Fit the air filter screen (2).
7. Refill new oil to 2/3 ~ 3/4 of the level gauge ([see "Filling Capacities" on page 5-14](#)) into the hydraulic oil tank.
8. Check the filler cap (1) and replace it if necessary.
9. Install the filler cap (1) of the hydraulic oil tank.
10. Start the engine and run the engine for 5 minutes.
11. The oil level should be between 2/3 ~ 3/4 of the level gauge. If necessary, fill hydraulic oil through the filler.
12. Shut down the engine.

5.6.2 Hydraulic Oil Filter–Replace

Replace the hydraulic oil filter element every time when you change the hydraulic oil. Otherwise the hydraulic oil may be contaminated by the impurity on the old hydraulic oil filter.

Steps of changing the element of high-pressure filter.

1. Disassemble the element

- 1) Loosen the hexagon bolt at the bottom of filter with a special spanner and then remove it.
- 2) Pull out the filter element by hand.
- 3) Drain off the rest of the hydraulic oil and clean the filter housing and cover.

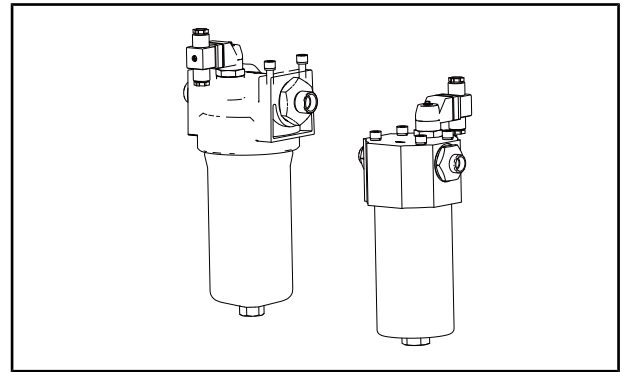

Fig 5-42

2. Install a new element

- 1) Insert the new filter element into the filter cover.
- 2) Screw up the filter housing by spanner, and then loosen it in the opposite direction for 1/4 circle.

NOTE :

Keep the oil fillers and elements clean in the process of replacement. The old element should be discarded and can't be reused after cleaning.

5.7 Maintenance for the A/C

5.7.1 A/C-Check/Maintain

In order to keep good performance, reliability and prolong the service life of the A/C unit, pay attention to the following items when using the A/C.

Instructions for using the A/C

- Maintain the A/C according to the producer's instructions.
- Before turning on the A/C, first you have to start the engine. Wait a few minutes for the engine to work smoothly, then you can start the A/C and choose the proper fan speed and temperature.
- Close the window and doors when using the A/C. Save the energy.
- When exchanging the air without opening the window or doors, you can just turn on the fan speed control.

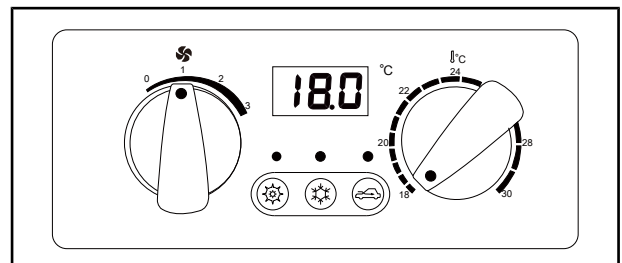

Fig 5-43

Maintaining intervals for the A/C

(a) Compressor

- Check and maintain it once every two years generally. Mainly check the inlet/discharge pressure and the fasteners for looseness and air leak.
- Disassemble the compressor to check the inlet/discharge valve for damage and distortion. If any, repair or replace the relevant valve.
- Replace the seal ring and shaft seal if the compressor is disassembled and repair it. Otherwise, it may cause leak at the compressor seal.

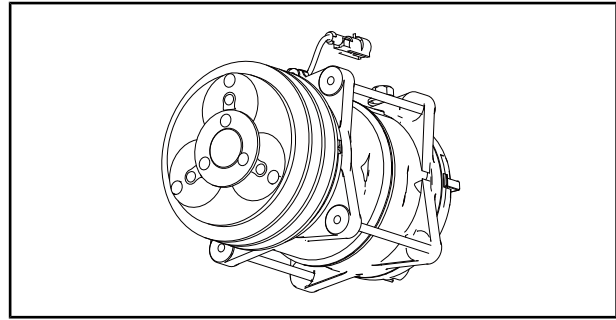

Fig 5-44

(b) Condenser and cooling fan

The condenser is installed behind the radiator.

- Check and maintain them once a year generally. Clean the condenser plate with compressed air and cold water; rectify and repair the radiator gill by a pair of flat-nosed pliers; carefully check the condenser surface for abnormality; check for refrigerant leak with a leak detector.
- Recoat the antirust paint in case of peeling-off to prevent leak due to rusting and perforation.
- Check whether the cooling fan can normally run and whether the electric brush of fan motor is evenly worn.

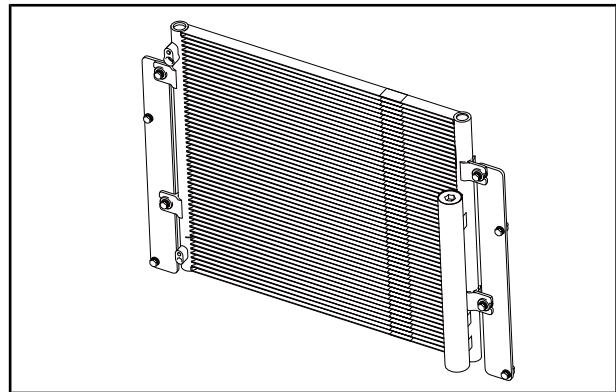

Fig 5-45

NOTE :

If you need to add refrigerant, please refer to the F-Gas decal for specific dosage.

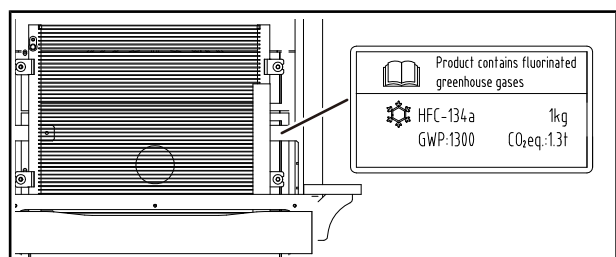

Fig 5-46

(c) Evaporator

- Generally, check it for leak with a leak detector once a year.
- Open it to clean the inner and the air duct once every 2 years to 3 years.

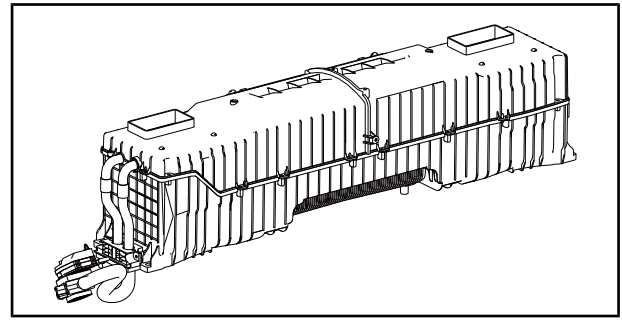

Fig 5-47

Inform the service department to replace the drier/collector. Check the A/C system.

⚠ WARNING

Risk of personal injury!

The corrosion or mechanical damage of drier/collector could cause explosion, which could cause personal injury.

Replace the drier/collector if necessary.

NOTE :

To ensure the performance of the A/C, ask the service department to replace the drier/collector before yearly operation season.

(e) Refrigeration pipeline

- Pipe connectors: Check them once every year, and check its sealing with a leak detector.
- Pipes: Check them for collision with other parts; check the rubber hoses for aging and crack. Replace the rubber hoses every 3~5 years.

Table 5-11 Checking intervals for the A/C

Item	Maintenance	Interval
Pipeline connector	Check the locking nuts for looseness; check the rubber hoses and connectors for refrigerant leak and oil stain; check the rubber hoses and pipes for crack, aging, embrittlement, damage by compression, and collapsing.	Once/month
Condenser	Check the fin for distortion and make it in order if any; check the core for blockage and clean it if any.	Once/month
	Check the fan for damage and abnormality.	Once/month
Evaporator	Clean the air-in/out ducts; check the bottom drain pipe for blockage and smoothen it if necessary	Once/year
Liquid storage	Check the pressure switch connector for looseness.	Once/quarter

Table 5-11 Checking intervals for the A/C (continue)

Item	Maintenance	Interval
	Replace the liquid storage after the A/C has been used for some time	Every 1000 h
Refrigerant volume	Check the refrigerant volume from the inspection window when the A/C runs. There shall be few or no air bubble; otherwise, add refrigerant.	Once/month
Compressor	Check the fastening bolts for looseness.	Once/month
	Check the fitting surface and the rotary shaft seal of main shaft for refrigerant leak and oil stain.	Once/month
	Check the compressor belt for wear and replace it if necessary.	Once/month
	Check the belt for tension and tension it if necessary.	Once/month
	Start and run the A/C for a few minutes in the seasons when the A/C is unused.	Once/month

5.7.2 Compressor V-belt-Check/Replace

WARNING

Risk of personal injury!

Working on the V-belt during it operation could cause personal injury.

Work on the V-belt only when the engine shut down.

V-belt-check

1. Inspect the entire circumference of the V-belt visually for damage and cracks. Replace damaged or cracked V-belts.

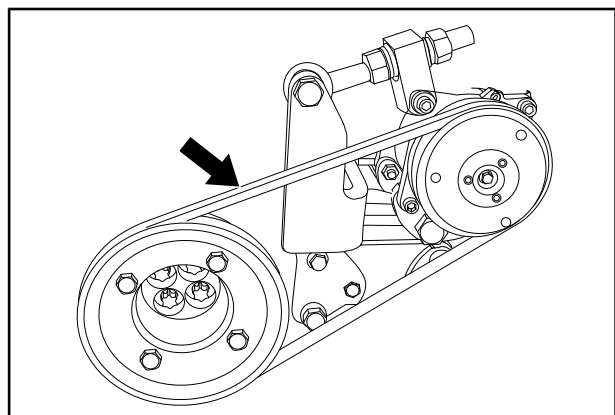

Fig 5-48

2. Press the V-belt with thumb to check if the V-belt can be depressed more than 10 mm - 15 mm between the V-belt pulleys and retighten if necessary.

V-belt-tighten

1. Slightly slacken fastening screws (6), (7), (8), (9).

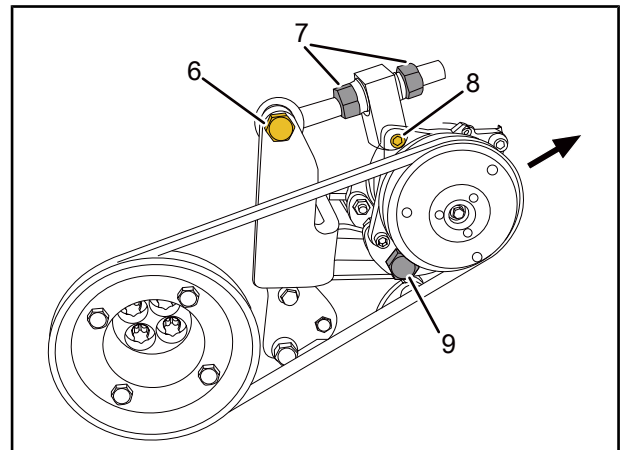

Fig 5-49

- | | |
|----------|----------|
| 6. Screw | 8. Screw |
| 7. Screw | 9. Screw |

2. Press the compressor in direction of arrow, until the correct V-belt tension is reached.
3. Retighten all fastening screws.

V-belt-change

1. Slightly slacken fastening screws (6), (7), (8), (9).
2. Push the compressor against the direction of arrow completely against the engine.
3. Remove the radiator net cover, loosen the installation bolt of the engine fan from the end face with a wrench, remove the fan and take out the compressor belt.
4. Fit the new V-belt to the V-belt pulleys.
5. Tension the V-belt as previously described.
6. Check the V-belt tension after a running time of 30 min.

5.8 Maintenance for the Electric System

5.8.1 Battery-Maintain

⚠ WARNING

Risk of death or personal injury!

Open fire and smoke could cause explosion when working on the batteries, which could cause death or personal injury.

When working on the batteries, do not work on area where there is open fire or smoke.

⚠ CAUTION

Risk of personal injury!

Battery acid could erode skin, which could cause skin injury.

Wear proper clothes to avoid skin from erosion by acid when filling acid to the batteries.

The battery is located near the steps. The battery must be securely installed on the roller:

NOTICE

Risk of machine damage!

Leaving tools intentionally or unintentionally on the batteries could cause short circuit and influence the electric devices.

Never leave tools on the batteries.

1. Connect to the positive electrode (+) first and then connect to the negative electrode (-), and apply a small amount of lubricating grease to the wiring terminal.

2. When taking out the battery, first cut off the negative wire (-) and then cut off the positive wire (+).

Maintenance steps for battery:

1. Open the cover of battery tank.
2. Clean the battery tank and battery surface.
3. Clean the battery electrode and electrode holder, and apply the lubricating grease for lubrication.
4. Inspect the fastening of electrode terminal of battery.

The following maintenance is conducive to extending the service life of the battery:

- Switch off all electrical appliances (such as ignition switch, lamps, indoor lamp and radio).

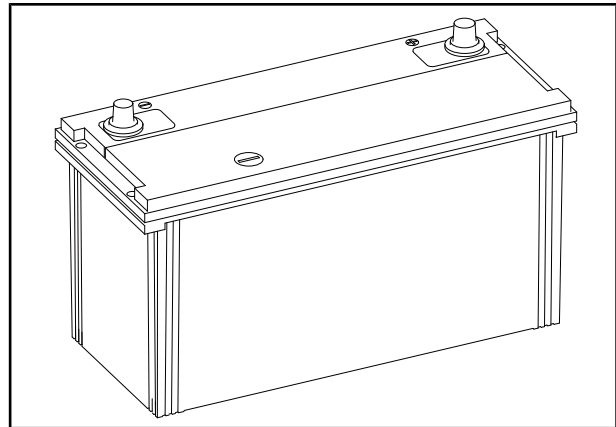

Fig 5-50

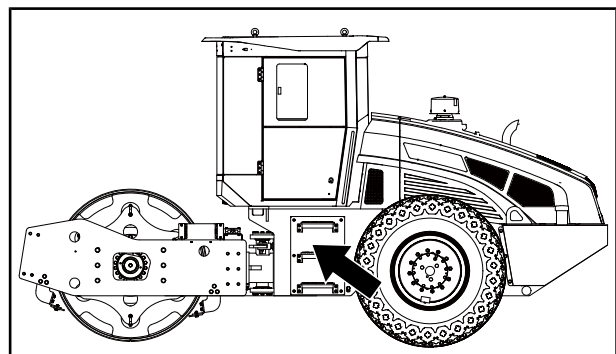

Fig 5-51

- Inspect the open-circuit voltage of the battery on a regular basis, at least once a year.
- When the open-circuit voltage is 12.25 V or below, please recharge the battery once again immediately without supercharging.
- After recharging each time, it is recommended to rest the battery for 1 hour before use.
- If the battery is not used for more than one month, disconnect the battery and do not forget to inspect the open-circuit voltage on a regular basis.

5.8.2 Electric Box-Maintain

NOTICE

Risk of machine damage!
Control module could become invalidated if the electric box gets wet.
Keep the electric box dry when maintaining the electric box.

Take the following steps to maintain the electric box.

1. Unlock the door of the electric box.

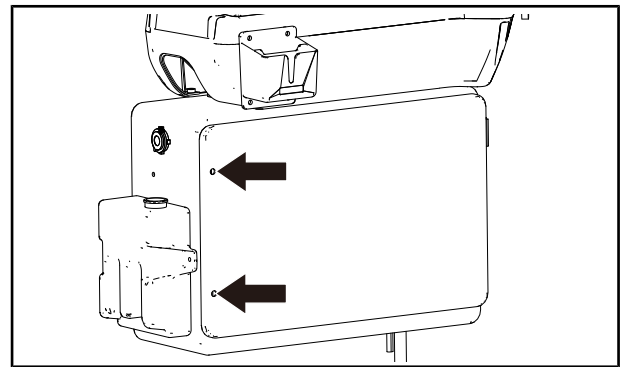

Fig 5-52

2. Use a dry brush to clean out the dust lightly.

3. Check the connection of each electric contact point.

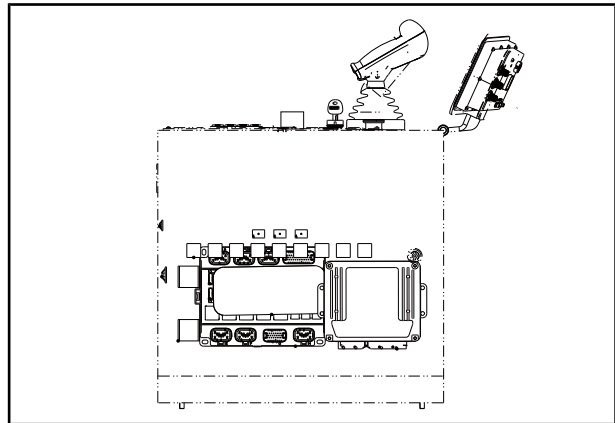

Fig 5-53

4. Lock the door of the electric box.

5.8.3 Fuse-Replace

Check the fuse to see whether they are in good condition or not.

NOTICE	
<p>Risk of machine damage! Improper fuse could melt easily when circuit is overloading. This could cause the electric system failure. Use proper fuse with right capacity when replacing a new fuse.</p>	

The inspection and replacement steps are as follows:

1. Open the centralized control box in the cab.

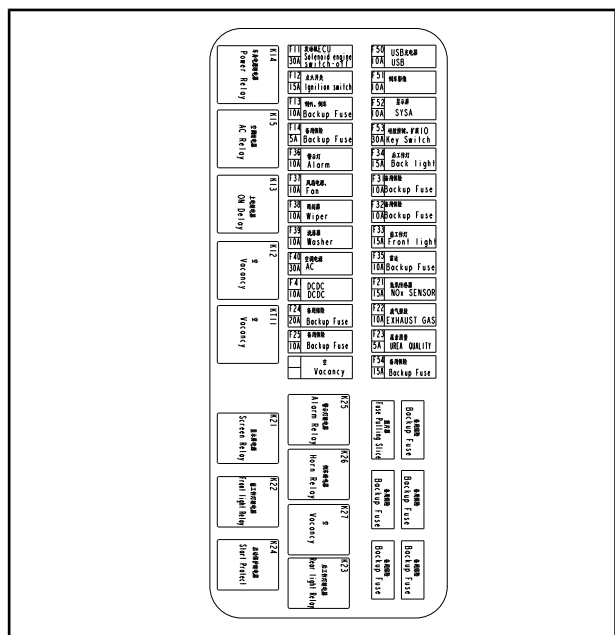

Fig 5-54

2. Take out the fuse inserted in the central control box with tweezers.

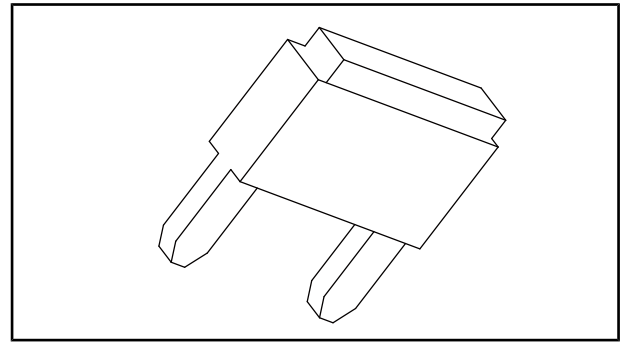

Fig 5-55

3. Observe if the fuse is damaged by looking forward the light.
4. If the fuse is damaged, take out the corresponding standby fuse above central control box with tweezers.
5. Insert the corresponding standby fuse of the right capacity with tweezers for the replacement.

5.9 Maintenance for the Mechanical System

5.9.1 Grease for Propel Bearing-Fill

Take the following step to fill the propel bearing with grease:

1. Set the machine levelly.
2. Remove the screw plug (1)(2) of oil port on the propel bearing.

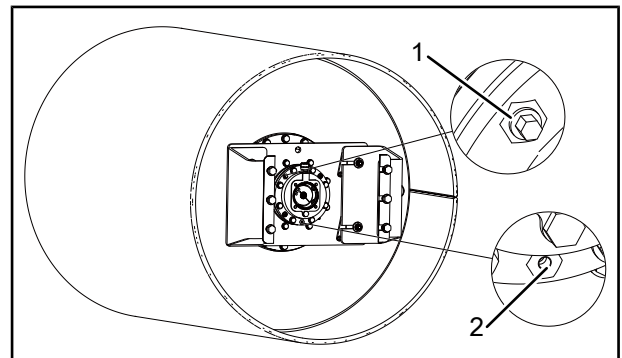

Fig 5-56

1. Screw plug

2. Screw plug

3. Fill 2/3 of the bearing chamber with appointed lithium grease through the screw plug (1) ([see "Filling Capacities" on page 5-14](#)), until you can see oil out of the screw plug (2).
4. Fit them back.

5.9.2 Grease for Central Articulation Frame-Fill

The four bearings are self-lubricating and there is no need to lubricate them in daily work. You only need to apply a little grease on the surface before machine assembly for easy operation.

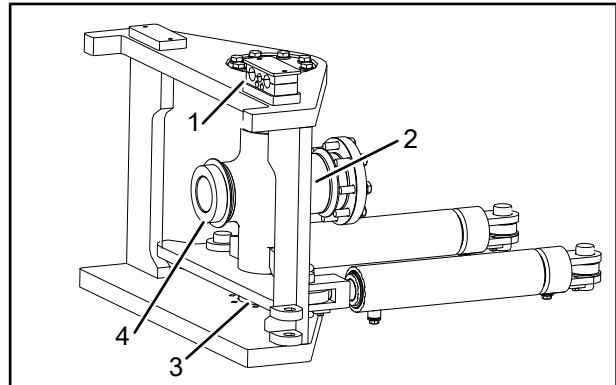

Fig 5-57

- | | |
|------------|------------|
| 1. Bearing | 3. Bearing |
| 2. Bearing | 4. Bearing |

5.9.3 Lubricant for Drum Vibration Bearing-Replace

Take the following step to change lubricant.

1. Set the machine levelly.
2. Turn the vibratory drum assembly to set one outlet on the drum bearing seat at the lowest position.

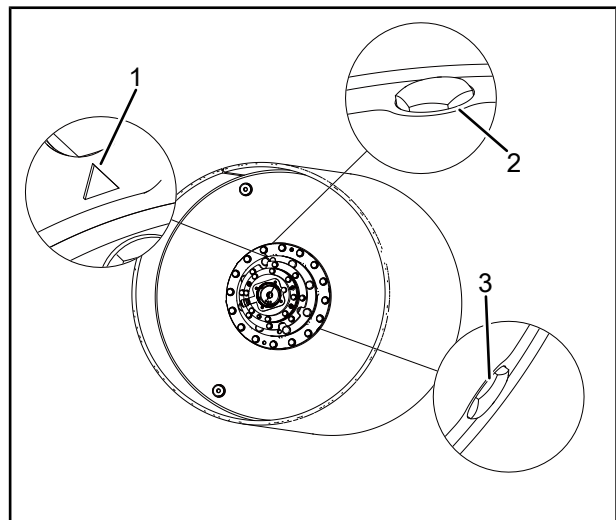

Fig 5-58

- | | |
|------------------|-----------------|
| 1. ▲ mark | 3. Lower outlet |
| 2. Higher outlet | |

3. Place a vessel (volume should be more than 13 L) under the outlet . Remove the oil drain plug to drain the oil.
4. Rotate the drum to make the place with ▲ mark (1) at the top position.
5. Remove all plugs and washers of the higher outlet (2) and lower outlet (3).

6. Fill the drum with appointed lubricant (see [“Filling Capacities” on page 5-14](#)) through the higher outlet (2) until lubricant flows out a little from the lower outlet (3).
7. Clean the plugs, reinstall and tighten them.

5.9.4 Lubricant for Reducer-Replace

The maintenance for the reducer is mainly to add and drain lubricant.

Lubricant-drain

1. Place a vessel under the oil outlet (3). Remove the plug and drain the lubricant.

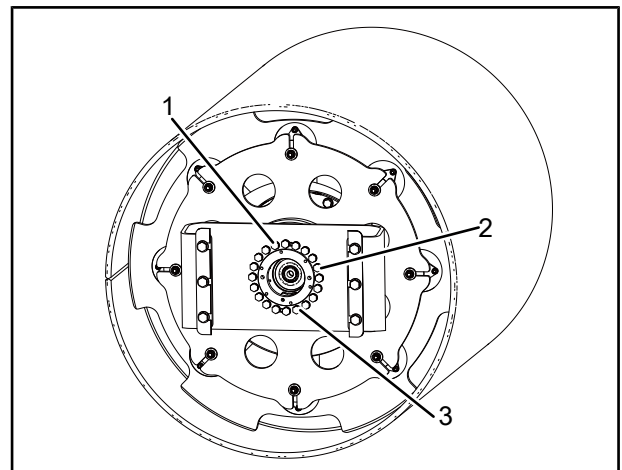

Fig 5-59

- | | |
|--------------|---------------|
| 1. Oil inlet | 3. Oil outlet |
| 2. Oil level | |

2. After draining the lubricant, screw the plug back tightly.

Lubricant-add

1. Remove the plug of oil inlet (1) and plug of oil level (2).
2. Add appointed lubricant. See [“Filling Capacities” on page 5-14](#) through inlet. When oil overflows from the oil level (2), then stop adding oil.
3. Screw the plugs of oil inlet (1) and plug of oil level (2) back tightly.

5.9.5 Lubricant for Rear Axle-Replace

The right figure shows the oil filler and the oil drain.

Central reducer assembly and main reducer:

- Oil drain: unscrew the plug at the oil draining port (3) to drain the oil.
- Oil filling: unscrew the plug at the oil filling port (1) and fill oil until the oil overflows from the oil level port (2).

Wheel end :

- Oil drain: rotate the port (4) to make it at the lowest position and then unscrew the plug to drain the oil.
- Oil filling: unscrew the plugs at the port (4). Fill oil until the oil overflows from the port (4).

The table as follows shows the oil brand, change intervals and dosage.

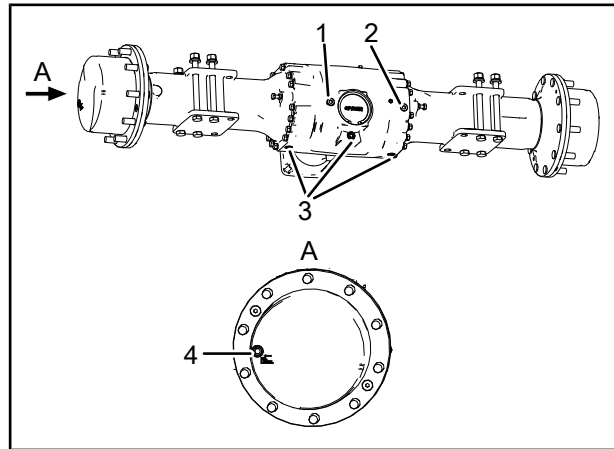

Fig 5-60

- 1. Oil filling port
- 2. Oil level port
- 3. Oil draining port
- 4. Oil filling/drainage/level port

Table 5-12 Oil Change Intervals for Rear Axle

Item		Intervals	Oil brand and dosage	
Level check	Main reducer	Every month	Heavy-duty vehicle gear oil GL-5 85W-140	
	Central shell	Every month		
	Wheel side reducer	Every 250 h		
Oil change	Main reducer	Every 500 h, 50 h at first time		2 L
	Central shell	Every 500 h, 50 h at first time		10 L
	Wheel side reducer	Every 500 h, 50 h at first time		4 L×2

5.9.6 Damper-Check/Replace

- Check the dampers. Make sure that there is no big crack (should be less than 15 millimeters) on the dampers (shown in right figure). Otherwise, replace the worn dampers.
- Check the connecting bolts and nuts are connected firmly. If not, tighten the fastener.

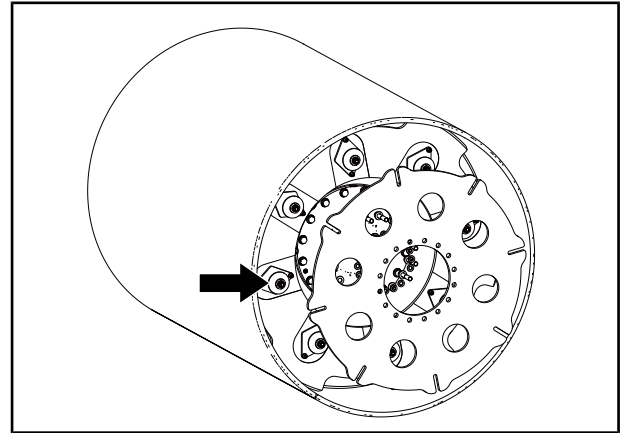

Fig 5-61

5.9.7 Windshield Washer Fluid–Check/Fill

The windshield washer reservoir is located in the cab.

Take the following steps to check the windshield washer fluid level and fill:

1. Open the right door of the cab and see the washer reservoir located at the back of the seat.
2. Observe the liquid level of the detergent in the washing storage tank. If the liquid level is lower than 1/3, the detergent requires to be supplemented.
3. Unscrew the cover over the washing storage tank and add the detergent to fully.

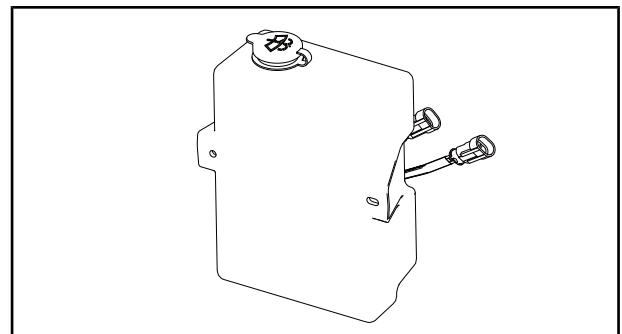

Fig 5-62

4. Fasten the cover over the washing storage tank after the filling of the detergent is completed.

NOTICE

Risk of machine damage!

In cold weather, water pump, solenoid and filter could freeze up, which could cause machine damage.

Drain the water from water spraying system and add antifreeze in cold weather.

NOTE :

The spray nozzle of the windshield washer can be adjusted to spray the washing fluid to the desired direction.

NOTE :

Start the water spraying system to spray water until the antifreeze is sprayed from the nozzle, after the ice period, drain the antifreeze and dispose it in an environment- friendly way.

5.9.8 Oil tank and Pipes–Check

Check oil tank and pipes for damage or leakage. If any, repair or replace them immediately in accordance with required safety procedures.

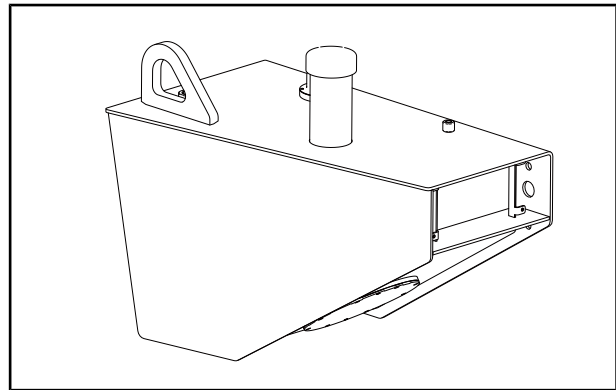

Fig 5-63

SANY

Troubleshooting

6 Troubleshooting	6-1
6.1 Mechanical Parts.....	6-3
6.1.1 Engine.....	6-3
6.1.2 Vibratory Drum	6-4
6.1.3 Propel System	6-5
6.2 Electrical Parts.....	6-5
6.2.1 Basic Electrical System.....	6-5
6.2.2 Electrical System of Working Devices	6-6
6.3 Air Conditioning System.....	6-6

6.Troubleshooting

6.1 Mechanical Parts

6.1.1 Engine

Table 6–1 Fault Analysis and Troubleshooting for Engine

Fault Symptom	Cause	Remedy
Engine can not be started.	Fuel used up.	Fill up fuel and bleed system.
	Fuel filter blocked.	Replace (see “Fuel Filter–Replace” on page 5-39).
	Leakage of fuel pipe.	Check and tighten all connections.
Difficult startup or unstable working power of engine.	Engine oil with excessive viscosity, especially in winter.	Use appropriate engine oil (see “Oil & Fluids Selection ” on page 5-9).
	Block in fuel system caused by the paraffin in winter, unsmooth fuel supply,	Replace fuel filter (see “Fuel Filter– Replace” on page 5-39), check all oil pipes and use the winter-grade diesel when it turns cold (see “Oil & Fluids Selection ” on page 5-9).
	Dirty air filter.	Clean or replace (see “Air Filter–Clean/Replace” on page 5-22).
	Too tight throttle cable.	Adjust the nut on throttle cable.
	Defective vacuum switch.	Check vacuum switch (see “Oil Water Separator– Check/Drain/ Replace” on page 5-29).
Too much smoke discharge.	Too much engine oil.	Drain redundant engine oil (see “Engine Oil-Check/Refill/Change” on page 5-26).
	Dirty air filter.	Clean or replace (see “Air Filter–Clean/Replace” on page 5-22).
Engine too hot or shut down suddenly.	Cylinder or cooling fan of radiator at the top of cylinder blocked by dirt.	Clean cooling fan of the radiator, esp. the vertical fin at the top of cylinder (see “Radiator– Check/Clean” on page 5-33).
	Block in air filter.	Clean or replace (see “Air Filter–Clean/Replace” on page 5-22).

Table 6-1 Fault Analysis and Troubleshooting for Engine (continue)

Fault Symptom	Cause	Remedy
Charging alarm indicator of storage battery lit on during operation.	Too low engine speed.	Check, adjust or replace the engine belt (see “Engine Belt-Check/Replace” on page 5-36).
Insufficient power of engine.	Too much engine oil.	Discharge redundant engine oil (see “Engine Oil-Check/Refill/Change” on page 5-26).
	Dirty air filter.	Clean or replace (see “Air Filter-Clean/Replace” on page 5-22).
	Leakage of pressure tube.	Tighten the screws and nuts of tube.
Crankshaft rotates slowly and can not be started.	Loose and eroded wiring of battery.	Clean and tighten the wiring.
	Incorrect lubricating oil model.	Change it with the lubricating oil of specified grade (see “Oil & Fluids Selection ” on page 5-9).
Crankshaft rotates normally but can not be started.	No fuel in oil tank.	Refill (see “Fuel-Check/Refill/Replace” on page 5-37).
Unstable idling.	Improper adjustment of throttle cable.	Adjust throttle cable to natural condition.
	Fuel leakage.	Check and tighten the leaked part. If can't resolve it, please contact Sany or Sany dealer.

6.1.2 Vibratory Drum

Table 6-2 Fault Analysis and Troubleshooting for Vibratory Drum

Fault Symptom	Cause	Remedy
No vibration or small vibration at both positions of vibration switch.	Incorrect position of vibration switch.	Set switch to position I (see “Control Console” on page 3-3).
Air in hydraulic system.	Insufficient oil in hydraulic oil tank.	Check oil level and refill new oil (see “Hydraulic Oil-Check/Refill/Change” on page 5-41).
	Oil-suction tube not sealed.	Check oil-suction tube and tighten connecting elements.

6.1.3 Propel System

Table 6–3 Fault Analysis and Troubleshooting for Propel System

Fault Symptom	Cause	Remedy
Air in hydraulic system	Insufficient oil in hydraulic oil tank	Check oil level and refill new oil (see “Hydraulic Oil-Check/Refill/Change” on page 5-41).
	Oil-suction tube not sealed	Tighten connecting elements
Large impact in transmission system or torpid steering	Insufficient lubricating grease	Fill grease (see “Grease for Propel Bearing-Fill” on page 5-53).

6.2 Electrical Parts

6.2.1 Basic Electrical System

Table 6–4 Fault Analysis and Troubleshooting for Basic Electrical System

Fault Symptom	Cause	Remedy
No power supply of complete machine.	Fuse burnt.	Open fusebox, pull out the damage fuse, and insert the spare fuse of the same model.
Failure of engine startup.	Fuse (F12、 F53、 F54 and F11) burnt.	Open fusebox, pull out the damage fuse, and insert the spare fuse of the same model.
	Traveling handle and vibration selection switch not set at neutral position.	Set traveling handle and vibration selection switch to the neutral position (see “Control Console” on page 3-3).

Table 6–5 Fuses

Code	Part	Current	Code	Part	Current
F11	Solenoid engine switch-off	30 A	F50	USB	10 A
F12	Ignition switch	15 A	F51	Reverse camera	10 A
F13	Backup fuse	10 A	F52	SYSA	10 A
F14	Backup fuse	5 A	F53	Key switch	30 A
F36	Alarm	10 A	F34	Back light	15 A

Table 6–5 Fuses (continue)

Code	Part	Current	Code	Part	Current
F37	Fan	10 A	F31	Backup fuse	10 A
F38	Wiper	10 A	F32	Backup fuse	10 A
F39	Washer	10 A	F33	Front light	15 A
F40	AC	30A	F35	Radar	10 A
F41	DCDC	10 A	F21	NOx sensor	15 A
F24	Backup	20 A	F22	Exhaust gas	10 A
F25	Backup	10 A	F23	Urea quality	5 A
			F54	Backup fuse	15 A

6.2.2 Electrical System of Working Devices

Table 6–6 Fault Analysis and Troubleshooting for Electrical System of Working Devices

Fault Symptom	Cause	Remedy
No traveling or sluggish traveling.	Brake switch and emergency stop switch not reset.	Reset brake switch and emergency stopping switch (see “Control Console” on page 3-3).
No vibration.	Emergency stopping switch not reset.	Reset emergency stopping switch (see “Check the Emergency Stop Switch” on page 4-13).
	Traveling speed is over 1.5 km/h.	Adjust the gear switch to change the speed to less than 1.5 km/h (see “Control Console” on page 3-3).
	Vibration button have been pressed.	Press down the vibration button. Stop vibration forcibly (see “Control Console” on page 3-3).

6.3 Air Conditioning System

The common faults of air conditioning system generally are electrical faults, mechanical faults, re-frigerant and freezing lubricant failures.

The symptoms are no cooling or insufficient cooling or abnormal noise.

Table 6-7 Common Faults and Troubleshooting of Air Conditioning System

Fault Symptom	Cause	Remedy
Abnormal sound in conveyor belt.	Too loose conveyor belt.	Adjust belt tightness (see “Compressor V-belt- Check/Replace” on page 5-48).
Abnormal sound in evaporator.	Foreign matter enters the evaporator.	Open evaporator cover and take out foreign objects (see “A/C-Check/Maintain” on page 5-45).
The fan operates normally but the air volume is too small.	There are barriers on the air suction side.	Clean (see “A/C-Check/Maintain” on page 5-45).
	The fin of evaporator or condenser is blocked.	
The compressor does not work or it is difficult for the compressor to operate.	The tension of compressor belt is insufficient, and the belt is too loose.	Tension (see “Compressor V-belt-Check/Replace” on page 5-48).
The warm air offsets the refrigerating effect and thus the refrigerating effect is poor.	The hot water valve is not closed.	Close the hot water valve (see “A/C-Check/Maintain” on page 5-45).
The condensation effect of condenser is poor.	The condenser is blocked up by dust or foreign matters.	Clean the condenser and clear the blocking (see “A/C-Check/Maintain” on page 5-45).

SANY

Specification

7 Specification	7-1
7.1 Dimension of the Equipment	7-3
7.2 Specifications of the Equipment.....	7-4

7.Specification

7.1 Dimension of the Equipment

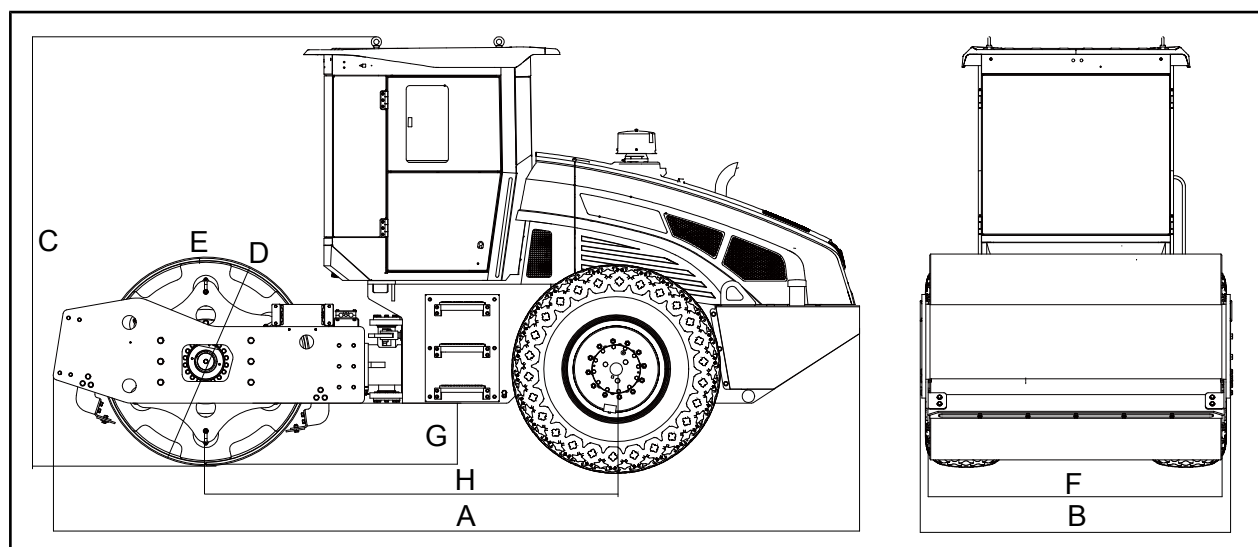

Table 7-1 Dimension of the equipment

	Item	Unit	Value
A	Length	mm	5800
B	Width	mm	2280
C	Height	mm	3000
D	Vibratory drum diameter	mm	1500
E	Thickness of vibratory drum rim	mm	25
F	Vibratory drum width	mm	2130
G	Min. ground clearance	mm	431
H	Wheel base	mm	2950

NOTE :

The above data are specifications of standard machine. Materials and specifications are subject to change without prior notice in accordance with our continuous technical innovations.

7.2 Specifications of the Equipment

Table 7-2 Technical Specification

	Technical Parameters		Value
Mass and load	Operating mass (kg)		13000
	Distributing mass of vibratory drum (kg)		6800
	Distributing mass of drive axle (kg)		6000
	Static linear load of vibratory drum (N/cm)		329
Compaction mechanism	Vibration frequency (Hz)		30/35
	Nominal amplitude (mm)		1.8/0.9
	Exciting force (kN)		280/178
Power-driving performance	Travel speed (km/h)	Low speed	0 ~ 3.5 0 ~ 6
		High speed	0 ~ 7 0 ~ 9
	Gradeability (%)	Theoretical	60
		Practical gradeability	55
	Steering angle (°)		±35
	Swing angle (°)		±12
	Min. turning outside diameter (mm)		11915
Engine	Manufacturer		DEUTZ
	Model		TCD4.1 L4
	Rated power (kW)		115
Capacity	Battery (VxAh)		24×120
	Fuel tank (L)		220
	Hydraulic oil tank (L)		80

NOTE :

The above data are specifications of standard machine. Materials and specifications are subject to change without prior notice in accordance with our continuous technical innovations.

SANY

Optional Configuration

8 Optional Configuration	8-1
8.1 Removable Padfoot	8-3

8. Optional Configuration

8.1 Removable Padfoot

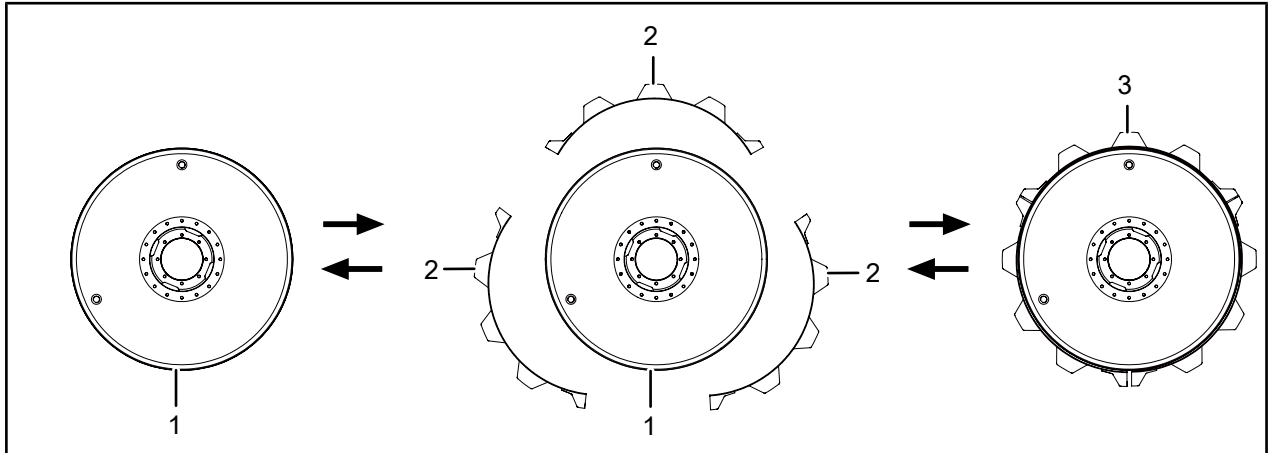

Fig 8-1

1. Smooth roller 2. Padfoot components 3. Removable padfoot roller

The assembly of 3 padfoot components through fastener connection on the smooth roller is the removable padfoot roller, which can be freely disassembled and assembled according to the specific construction conditions. The removable padfoot roller is mainly used for compacting building stones such as clay, semi-clay, sandy soil, sandy gravel soil, expansive soil and cinder.

NOTE :

Do not use rollers with welded or removable padfoot for compacting stone materials such as gravels, blasting rocks and rockfill. Padfoots could wear or crack for such operation. All those consequences will be born by the user.

The performance of the scraping teeth (4) to reduce the accumulation of mud and the corresponding reduction in climbing slopes for removable padfoot roller. Check the scraping teeth (4) before starting.

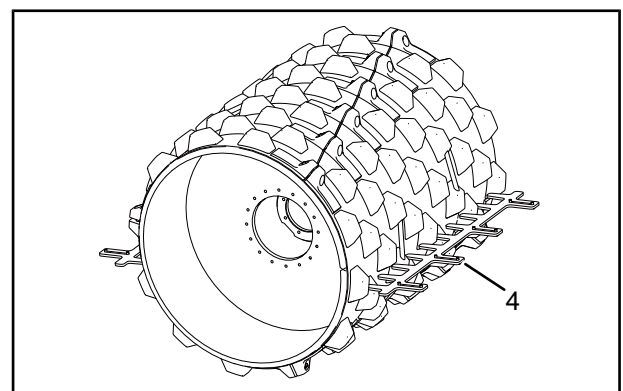

Fig 8-2

4. Scraping teeth

Take the following steps to check the scraping teeth:

1. Stop the machine on a flat ground.
2. Do service brake and turn the key to position O.

3. Clean the mud on the front and rear scraping teeth.
4. Check whether the clearance between the scraping teeth tip and the roller is about 30—35 mm.
If not, adjust the clearance and tighten the bolts.

SANY

Disposal

9 Disposal	9-1
9.1 Disposal of Product.....	9-3

9. Disposal

9.1 Disposal of Product

When the machine is removed from service, you must contact your nearest SANY dealer and dispose the product under the guidance of your nearest SANY dealer. Pay special attention to the following things :

1. Always dispose the product according to local regulations and environment protection rules.
2. Collect all fuels and lubricants properly. Do not drain them directly to the ground, collect the with appropriate container.
3. Pay special attention to the battery. Keep them away from open fire and smoke to avoid explosion.

www.sanyeurope.com

 **Sany Europe GmbH**

Sany Allee 1, 50181 Bedburg, Germany

Tel: +49 2272 90531 100

E-mail: info@sanyeurope.com

Website: www.sanyeurope.com

